

- Research & Development (R&D)

- ❖ Research Studies/Research Papers/patent
- ❖ Product Development
- ❖ Technology Upgradation
- ❖ Standardisation: (Input – Process – Output)
- ❖ Sponsored Projects

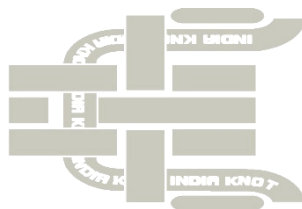

India Knot- A proprietary one of IICT supplement to Make in India Mission

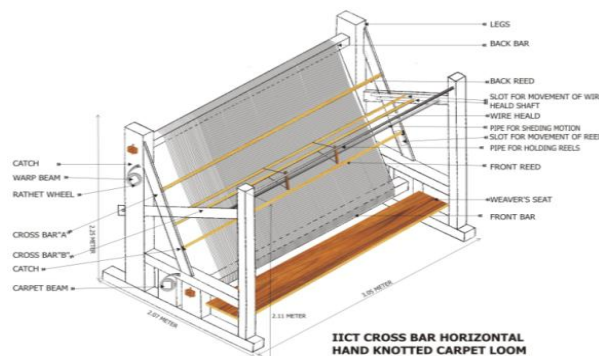

A proprietary one supplement to Make in India Mission

3.1 Research Studies:

- Regeneration of cellulose from Coir-Pioneer research work has been done to convert coconut shell waste to paper and art silk.
- Development of Stretch/sprout resistant pile named as "Terryleno".

The above initiatives expect to attract capital and technological investment in India in carpet and textile sectors to supplement Make in India in a big way.

3.2 Product Development: Quit a few product development activity has been done at institutional level and or in collaboration which includes Coir Based Carpet, Silk Carpet, Eri silk Carpet. Modacrylic based carpet, Handmade Astroturf type Carpet, Natural fibre based carpet, Natural dyeing, Organic product, Substitute to polyester shaggy, Bhujbun Utilisation (The problem of environment degradation out of disposal of waste / Bhujbun was tackled through R&D by means of developing out puts like tiles for floor /ceiling/as acoustic board besides as shoe bottom and cushion), Vertical Blind, Coir Paper and Coir Silk, Ergonomic and Flexible Tufting Frame, Metallic Loom for Hand knotted and



Snehabha carpet Backing - A proprietary one supplement to Make in India Mission

Tibetan, India Knot (A proprietary knot known as “India Knot” has been licensed to industry) etc. Quite a few consultancy assignments have also been completed.

3.3 Publications

There are number of publications.

Salient Publications are :

- Process control in Carpet Manufacturing- Book in English & Hindi published by M/s. Abhishek Publication.
- Process Control in Home Textiles- Book in English & Hindi published by M/s. Abhishek Publication.
- Deduction of Universal Relationship amongst Diameter (micron) and Linear density (denier) Published by Mellaind International.
- Performance Measurement & Management of Handmade Carpet Industry – Compilation by Research Scholar, facilitated by IICT for publication.
- Durability of handmade wool carpets: A review , Journal of Natural Fibers ,12:5,399-418).
- Modeling of Abrasion Resistance Performance of Persian Handmade Wool Carpets using Artificial Neural Network,

Journal of the Institution of Engineers (India): series E, 96:2, 175-180.

- Investigation on Durability of Handmade Woolen Carpets, Carpet-e-world, 45-48.
- Polymeric Carpet Backing: An Appropriate Concept for Technological Intervention, Carpet-e-World.
- Microscopic, IR spectroscopic & Thermal Analysis on Bio-degradability of Jute, Journal of Textile Association.
- Application of Cut Work on Cotton Fabric.

3.4 Patents

- Regeneration of cellulose from Coir-Pioneer research work has been done to convert coconut shell waste to paper and art silk-Concept has been covered under IPR vide application no. 149/KOL/2012.
- Stretch/sprout resistant pile named as "Terryleno" has been conceived and covered under IPR vide application No. 3755/DEL/2016 dated 17/11/2015. The validation is expected to produce niche product for Home Textile output: Towel and carpet.

		<p>3.5 Sponsored Projects : Details annexed as Annexure-B.</p> <p>Quality/Mentor Circle for IICT: IICT launched Quality/Mentor Circle for IICT-Industry Interface in the leadership of Director of Institute, to create discipline in students including attendance in theory and practical class, institute-industry linkage etc. The system is based on Kaizen Principle with the common and specific agenda.</p> <p><i>The above initiatives could focus at high quality standards and minimizing the impact on the environment in carpet and textile sectors to supplement Make in India through synergy in invention, innovation and education.</i></p>
--	--	---