



# INTEGRATED DPR

FEASIBILITY STUDY ON  
UPGRADATION OF IICT, BHADOHI TO A NATIONAL LEVEL  
TEXTILE INSTITUTE OF UNIVERSITY LEVEL



**Indian Institute of Carpet Technology**

Bhadohi, Uttar Pradesh, India

## CONTENT

1. Introduction : Background and references to exhibit Potentials , Comprehensive brochure
2. Credible Patents / Technology and Management Publications
3. Executive Summary
4. Survey details: Preliminary and Current
5. Detailed Project Report :Components
6. Conclusion : Report based conclusion and certification
7. Annexures : salient and pertinent

# 1

## INTRODUCTION

# Indian Institute of Carpet Technology

Knowledge and Technology Partner to the Industry

INVITES

INDUSTRY/STAKE HOLDERS TO EXPLORE PORTFOLIOS :

1.HRD, 2.DCD, 3.R&D AND 4.TSI TO ENHANCED THEIR PERFORMANCE



Indian Institute of Carpet Technology (IICT), Bhadohi, an institute with difference was conceived, by Ministry of Textile (MOT), Govt. of India (GOI) in eighties. IICT was

given the autonomous status in December 1998 through formation of society. Involvement of broad based stakeholders/authorities include Govt. of UP, Industry, Academicians, Industrial experts, statutory bodies/authorities like AICTE, University, NABL, IFW-MOT, experts from all region of the country in the Executive Committee Chaired by DC (Handicrafts) resulted role clarity and achievements.



Administrative Building of IICT

"IICT has always been at the forefront whenever there was a need of human resources and technology assistance to the industry."

Dr. KK Goswami, Director, IICT

**Role IICT played for Carpet Industry:** IICT played its role through created portfolios exclusively for carpet industry are depicted below:

## IICT PORTFOLIOS

### 1. HRD

(Human Resource Development)

**Introduced long term training like B.Tech & Diploma course.**

B. Tech Course in Carpet and Textile Technology (CTT): Started in the year 2001. Thereafter, specializations in Advances in Carpet Technology (ACT)/ Home Textile Technology (HTT)/ Textile Design Technology (TDT) have also been

integrated to B.Tech in CTT with the due approval of A. K. Technical University, Lucknow and accreditation to Textile Institute, Manchester, U.K. IICT has been awarded twice Star performing institute of the University.

[More Details please visit www.iiict.ac.in](http://www.iiict.ac.in)

**373 Students** serving the trade which includes higher studies in premier institutes like IITs, NITIE, ISM, IIM, NIFT

[More Details please visit www.iiict.ac.in](http://www.iiict.ac.in)

**252 students** are under going graduation. Every year 60 students are available for placement w.e.f. July month Industry to come forward & utilise these resource.

**Futuristic plan:** It has been

possible to draft the futuristic plan which includes introduction of M.Tech in Carpet & Textile Management with 20 intakes and Ph.D. Programme covering Pre Ph.D. Course Centre for Textiles at IICT. More labs are also going to be created to cover advanced and novel activities like advanced Carpet & Home textiles manufacturing, Fashion/ Style/Texture, Designs, Information Technology EDP, Personality Dev./ language skill including foreign language other than English.

In this endeavor a holistic approach of repositioning of IICT will be made. The DPR for Phase III expansion in hand to reflect the roadmap.

[More Details please visit www.iiict.ac.in](http://www.iiict.ac.in)



## International Distance Learning Programme (IDL P)

Certificate/ Diploma course through International Distance Learning program (IDL P) in collaboration with AG Research, New Zealand duly approved by DEC,IGNOU, MHRD, Govt. of India.

**Students' enrollment in process. Working person at large can take benefit.**

### Short term courses

More Details please visit [www.iict.ac.in](http://www.iict.ac.in)

Tailor made Industry driven Short Term Training programs run time to time.

### MES based:

Application of Computer and IT in Carpet Manufacturing. Carpet and Textile design using CAD

Carpet Yarn Dyeing

Carpet weaving

Spinning of woolen yarn

Washing & Finishing of Carpet.

More than 5000 persons have been trained so far to mitigate the skill gap.

**Through ISDS :** 566 have been trained & other 2000 are expected to complete by 2015 covering above mentioned 6 MES.

**Through CHCDS:** 3500 have been trained till date covering carpet weaving and another 1500 to be by the waving and other desired MES shortly.

Askill india-move, the industry to utilize these skilled manpower to mitigate the skill gap

**Industry to come forward and desire demographic dividend**

*(Job Creation and Skill Enhance - skill India in carpet and textile sector to supplement Make in India).*

## 3. R&D

## 2. D C D

### (Design Creation & Development)

Design Bank Created- More than 15000 designs are in place out of which around 3500 designs have been utilized by industry for commercial purpose. The variety of Design Bank includes Traditional INDIAN Motifs (Like : Harappa, Ajanta, Mughal, Rangoli, Jaipuri, Fulkari, Kantha, Paithani, Kalamkari, Banarasi, Jamewar etc. ), modern motifs etc. as per trend.

**Industry at large to come forward, advice and take more benefit of bank, creativity and development - global value at local cost.**

*(The above initiatives could focus on design creation and skill enhancement integrating Indiya collection an attempt to propagate Indian motif in carpet and textile sectors to supplement Make in India)*



## (Research & Development,

### Product Development:

Quite a few product development activities has been done at institutional level and or in collaboration which includes:

- Coir Based Carpet:
- Silk Carpet:
- Eri silk Carpet:

- Modacrylic based carpet:
- Handmade Astroturf type Carpet
- Natural fiber based carpet:
- Natural dyeing:
- Organic product.
- Substitute to polyester shaggy:
- Bujbun Utilization:
- Vertical Blind
- Coir Paper and Coir Silk:

Another revolutionary research supported by CCRI Alleppey, Kerala of Coir Board, Kochi is continuing for coir silk. Commercial Stage trials with reputed Rayon Manufacturing co.(Grasim & Century Rayon) are being undertaken. The value addition will benefit coconut growers and support industrialization for coir paper & coir silk Production in coconut production intensive states like Kerala, Tamilnadu of the country.

- Concept of Ergonomic and Flexible Tufting Frame:

▪ Cross Bar Horizontal Loom CBHL (Wooden or Metallic) for Hand knotted and Tibetan, Shaggy, Soumak etc - A proprietary move on supplement to Make in India Mission- Industry to come forward and explore



Weavers enjoying the comfort while working in CBHL

▪**India Knot:** A proprietary one of IICT which permits semi knotting its loom supplement to Make in India Mission - Industry to come forward & Explore

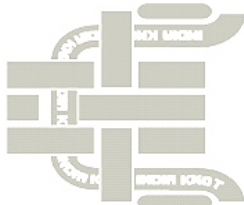

▪**Snehabha Carpet Backing System Polymer Backing Technology:** Light weight, Washable Reported it's features & feasibility in publications like carpet e world



▪**Terry leno Structure** :Another proprietary Make in India move to provide a new / cost effective carpet terry structure

The benefit of this R&D concept can be taken by carpet & Home textile includes towel industry at large to enhance their market/ market share/performance.

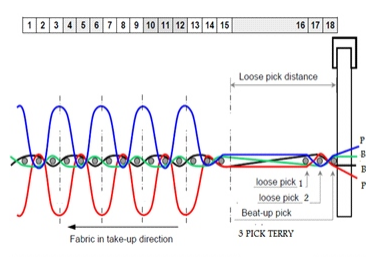

▪**Universal relation amongst diameter and linear density:** A published academic activity to supplement Make in India Mission :



**TSI**  
**(Technical Service Support to Industry)**

17170 testing services provided to industry so far.

Consultancy provided to many units & organizations of repute. Further local industry units have derived free liaison visit/ trouble shooting service of IICT. which has benefitted them for instant solution their problem.

Space for photograph Laboratory activities

IICT Laboratories are accredited to NABL (ISO 9001.2008). Industry can take benefit of accredited facilities of global level testing/certification at local cost

More Details please visit [www.iict.ac.in](http://www.iict.ac.in)

Recognized expression for predicting yarn diameter

$$d'' = \frac{1}{28\sqrt{Ne}} \text{ By F.T. Pierce, JTI 1937}$$

Revision of above to mitigate the limitation

Deduction of Universal Relationship

$$1. \quad d(\text{inch}) = \frac{1}{29.25\sqrt{Nec \times \sqrt{\rho_1}}} \quad 2. \quad d(\text{cm}) = 1130 \times \sqrt{\frac{ld}{yd}}$$

$$3. \quad d(\text{inch}) = 0.445 \times \sqrt{ld \times yv} \quad 4. \quad D = \left(\frac{M}{11.89}\right)^2 \times \rho$$

By K.K. Goswami, Melliand international, December 2015



# Indian Institute of Carpet Technology

Under the aegis of The Development Commissioner (Handicrafts)  
Ministry of Textiles Govt. of India  
Chauri Road Bhadohi

Phone: +91 - 5414 225504,228409, Fax: 225509, Email: iict@iict.ac.in, ictdmc@rediff.com

## Contact Details for exploration of portfolio wise output of IICT



# 2

## SALIENT CONTRIBUTIONS – PATENTS AND PUBLICATIONS

## SALIENT CONTRIBUTIONS – PATENTS and PUBLICATIONS

The institute has remained credible in research and development as evident from patents and publications. Few salient patents and publications are –

1. Indian Patent Number 211 274 for the invention entitled “ New Polymer Sheet Method, thereof and method of backing carpet or such thick fabric material with the same”
2. Indian Patent Number 214269 for the invention entitled “ A machine for backing carpet”
3. Trademark registered for above mentioned patents vide copyright number 1478866 & 1478867
4. Indian Patent Number 2796/DEL/2006 for the invention entitled “ Cross Bar Horizontal Loom”
5. Indian Patent Application number 34/KOL/2008 for the invention entitled “New Pile / knot formation”
6. Trademark registration of above as India Knot.
7. Copyright on CARPCOST software tool for cost control application filed.
8. Method of regenerating cellulose from coir fiber vide application number 149/KOL/2012
9. Method of developing sprout / stretch registered pile integrating terri and leno mechanism for producing value added towel and carpet vide application number 3755/DEL/2015

### PUBLICATIONS:

More than 40 include publication in International Journals like Textile Asia, Melliand Textile Berichte.

Publication include:

1. Woolenization of Jute as an Outlet for Jute as a alternative blanket
2. Carpet related publications, which include wool fibre, woolen yarn and carpet in wool perspective:
  - How to prevent slippage of Yarn in Fabrics?
  - How to prevent cockled appearance in Fabrics?
  - Optimization of Polyester/ Viscose Blends
  - Comparative study of the physical and mechanical properties of flat and Texturized Yarn Fabrics
  - Feasibility of setting up of 100 percent export oriented silk
  - Concept of polyester Filament Yarn Weaving
  - Studies of Blends with Special Reference to Acrylic Fibre as a partner
  - Outlet for Jute? Woolenized Jute & Viscose Blends
  - A study on value Loss
  - R&D Achievements claimed during last 3 years
  - Relationship between winding Breaks and Uster Classimat Faults
  - Effects of Alkali on Linen,

- Bleaching of Linen
- Flame Retardant Products – An in house R&D Effort for Defense end use – Symposium of Defense Textiles
- Report on Symposium on Defense Textiles
- Successful Development & Commercialization of pre-bleach (Linen) Technology
- Linen – An outstanding natural fibre,
- Bleach Lots Integrated,
- SEM and IR Studies on Linen
- Quality System Standards – A Management Approach towards TQM
- Industrial Textiles – An Overview,
- Total Quality Management – Its Principal and Approach
- Oxidative Bleaching System of Linen,
- Indian Carpets – Attracting Buyers Worldwide
- Carpet & Allied Textile Industry - Globalization Context
- Carpet Designing- An Overview
- Carpet Industry in View of Global Challenges
- Carpet yarn and Quality Control
- Carpet, Textiles, Handloom-In Retrospect & Prospect
- Colour - Application, Matching, Computerization in Carpet Perspective
- Handmade Carpet Industry
- IICT – A support to Carpet Industry
- Wool in Carpet Perspective
- Yarn in Carpet Perspective
- Carpet – A Potential sub-sector of Textiles
- CARPCOST – A software for Cost &Quality Control.
- Unpublished work/ Project involvement covers Natural fibers like PALF, COIR, BANANA, SISAL and Natural Processing: Dyeing/ Finishing



**Handmade Carpets:  
The Potential for Socio-economic Growth**

**Sandeep Srivastava, Additional Development Commissioner (Handicrafts), Office of  
the Development Commissioner (Handicrafts), Ministry of Textiles, New Delhi &  
Vice chairman, Indian Institute of Carpet Technology (IICT)**

**and**

**K.K. Goswami\*\*  
Director & Member Secretary, IICT, Bhadohi**

**Office of the Development Commissioner (Handicrafts)  
West Block No. 7, R.K. Puram, New Delhi-110 066**

## **Handmade Carpets – Potential for Socio-economic Growth**

**Sandeep Srivastava and K.K. Goswami**

### **Abstract**

The handmade carpet industry is a labour intensive one involving millions of artisans/craftspersons. Indian handmade carpet industry occupies a significant position in the world handmade carpet industry in particular and the international floor covering trade in general. The country with a population backed by skill and inclination towards such craft activity has a strong potential for growth. Engaging in such activity produces gainful employment resulting socio-economic growth. The handmade carpet industry is thus a potential socio-economic growth for any such country and the world at a large.

**Key Words:** Handmade Carpet, Labour Intensive, Skill, Craft, Gainful Employment, Potential, Socio-economic Growth.

### **Introduction**

The handmade carpet industry in India has about a 1% share of the total Global demand of Carpets. In recent years the handmade carpet sector has shown great improvement in relevant areas such as: competitiveness, capacities, delivery time and standardization.

India, with the help of more than 2500 exporters-cum-manufacturer and two million artisans, is ready for a big leap. Many major chain stores and department stores overseas are looking to India as a potential direct source for handmade carpets. Handmade carpet belts in India (maybe globally) lack infrastructural facilities, marketing and commercial support, and government support to achieve potential growth. This industry faces the problem of non-tariff barriers because of their insignificant size. The industry is not united, and does not have lobbyists to secure and promote its cause. The requirements of

WTO, ILO, human rights organizations, environment regulations are such that an underdeveloped country cannot meet them.

In this regard, the socio-economic conditions of the people of carpet-producing areas must be kept in mind. It is pertinent to mention that handmade carpets as a handicraft item were once of great aesthetic value. The beauty of traditional handicrafts such as handmade carpet should not be forgotten in the light of technological intervention. The craft – its beauty, labour intensiveness, the socio-economic conditions of the artisans, the availability of skill artisans, infrastructural set up, etc. – as indicates the potential scope of the sector. The simple existence of potential, however, may not yield desired growth until relevant organization are taken to establish economic targets and strategies for growth. Millions of artisans are already involved and many more millions can be included in the sector, providing opportunities to afford domestic economic development and enhance world trade.

### **The Handmade Carpet Sector: History and Prospects**

Indian handmade carpet industry exports products worth around 3,000 crore INR. The global market for exports is reported to be around 10,000 crore INR. India's share of the volume is the largest, but the value of these products stands third, indicating the realization of a low unit value. The share of India volume wise highest but value wise India stand third which indicates Unit Value Realisation is lower.

By comparison, Pakistan's carpet exports are reported to be valued at around 1000 crore INR. Interestingly, Pakistan's business is only in handknotted carpets and not in other variety like hand tufted, loom made etc. Diversity and the ability to meet customers' requirements makes India's potential to increase its volume and value much further.

There is a feeling that India alone can reach the goal of 10,000 crore INR in exports in the coming five years. Moreover, the large domestic market including meeting/creating the demand for handmade carpets among consumers including railways, hotels, airports, and corporate offices may be a boon for the Indian carpet industry. To achieve the

projected potential growth, much effort is required to ensure the resurgence of this vibrant sector in the interest of artisans and the domestic economy as a whole.

## **Methodology**

The following steps initial steps are suggested:

- Strength – Weakness – Opportunity – Threat (SWOT) Analysis: scientific analysis of the industry must be made through a systematic survey and made available by IICT to the industry;
- Action plan over SWOT information and database:  
An initial consideration of the means, financial implication and expected impacts must be undertaken;
- Studies of raw material requirements, processes, product upgrades and capacity building must be completed;
- Quality and quantity assessment vis-à-vis price and grades of raw material must be done in order to improve indigenous varieties and reduce imports;
- A raw material bank must be established to manage raw material qualities and supply;
- Process reengineering must be accomplished to ensure cost control, productivity enhancement, eco-friendly and socially accountable methods of production;
- A contract review system must be put in place;
- Customer-centred internal process controls must be introduced.

Next, a system of product-upgrading benchmarks must be initiated using two levels of data basing:

- Inter firm comparisons to create a database for 5%, 25%, 50%, 75% & 95% levels;
- The application of the database to grade the product according to both subjective and objective parameters in any group (5% to 95%);
- The extension of inter-firm and national standards to the international level.

Capacity building must address four main issues: human capital, networks, customer orientation, and research and development.

### Human Capital

- The industry must employ human resource strategies that focus on hiring qualified artisans and treating their skills as a form of capital;
- Incentives should be given to employees to maintain and improve their skills, perhaps through distance-learning programmes.

#### Networking

- Surface Networking must be developed so that each and every carpet belt may be considered as priority area for surface networking improving connectivity in terms of roadways and/or railways to improve the efficiency of the movement of people and materials;
- Information Networking which emphasizes Internet amongst all clusters through a suitable planning initiative should be used to share information about available resources;
- Information Network: Internet connectivity should be established amongst all clusters

through a suitable planning process using the NIC or some such organization to obtain and disseminate information about available resources and resource utilization, delivery and production;

- Utility Services: Reliable and adequate amounts of electricity and high quality water need to be ensured.

#### Customer Orientation

- Buyer-seller Interface: A primary focus on customer needs and satisfaction is essential to business success.

#### Quality Control and R & D

- The industry must be encouraged to create a Quality Control and R & D culture. The expenditure on investment should be taken from institutions such as IICT and suitably re-paid.

### **Strategy**

- Raw material base has to be stressed at the outset. This will enable strengthening our own raw material sources and overall raw material management (i.e., graded

wool consumption through a certified raw material bank), which is the first step toward successful brand imaging.

- Dynamic data basing using SWOT to provide comparisons to competing countries is required.
- Process re-engineering is another major step to reduce cost and upgrade quality. The quality cost concept can percolate through the industry and increase the chances of success.
- Standardization of products is crucial to the handmade carpet industry in order to raise customer confidence in the value of such high-priced products.
- Capacity building for this rural industry can take the sector to a new height; however, for network improvement is critical since the industry is weak, and needs immediate attention, investment, quality upgrades and continued network development immediately.

The suggested steps (and others to be added in light of ongoing experience) must be considered as an Integrated Carpet Improvement Programme through a Technology Mission for Carpet Textiles. The suggested Programme/Mission might be supported by an international body (IMF/World Bank/Asian Development Bank/UNDP/UNICEF/UNESCO etc.) in the general socio-economic interest.

### **Socio-economics**

Socio-economics is the study of the relationship between economic activity and social life. The field is multidisciplinary, using theories and methods from sociology, economics, history, psychology, and others. It is a relatively new social science that has emerged as a separate field of study in the late twentieth century. Most colleges and universities do not have a separate department or degree for socioeconomic studies.

Socioeconomics typically analyzes both the social impacts of economic activity and economic consequences of social activity. In most cases, however, socio-economists focuses on the social impact of economic change. Such change might include a factory



closing, market manipulation, the signing of international trade treaties, new natural gas regulation, etc. Such social effects can be wide-ranging in size, anywhere from local effects on a small community to changes to an entire society.

The goal of socioeconomic study is generally to bring about socioeconomic development, usually in terms of improvements in metrics such as GDP, life expectancy, literacy, levels of employment, etc.

### **Role of Social Responsibility in Carpet Trade**

In the early 1990s, intensive campaigns against the use of child labour led to a proposal to totally boycott the import of carpets from India. A boycott would have led to a disaster, with many families losing their earnings and would have further worsened the already severe problem of poverty. To avoid such negative consequences for workers, exporters and the whole carpet manufacturing regions, constructive solutions were needed. Consequently, RUGMARK, the initiative against the use of illegal child labour in the carpet industry, was begun in 1994 by Indian carpet manufacturers and exporters along with UNICEF and leading non-governmental organizations (NGOs) under the guidance of IGEP.

The problem of child labour is linked with various socio-economic conditions. Poverty is considered its main cause, which leads to illiteracy, low productivity, poor health and low life expectancy. The problem of child labour is thus a vicious circle. To help resolve it, RUGMARK is trying its best to break this circle by helping poor children. It is spreading awareness among the people in the carpet belt about the abuse of child labour and trying to improve the basis for structural changes.

With the experience of RUGMARK, IGEP is now working for the introduction of social standards on voluntary basis in the Indian industry. The strategy is based on improvement, support and co-operation. The goal is to improve the basic social and environmental conditions rather than stopping business relations on account of unsatisfactory conditions at work sites. Meanwhile, progress in the leather and textiles sectors is being made with the support of several Indian associations. This has encouraged IGEP to start ES Mark. “E” stands for ecological and “S” for social

responsibility. The ES mark will certify that the company meets ambitious social and environmental conditions in sectors like jewelry, handicrafts, sports goods and toys.

### **Potential for Growth**

A review of the handmade carpet sector in reveals a potential for capacity building. In the Indian context, the role of women could be one major factor for industry expansion in socio-economic terms.

- Training has covered the entire country but is rurally based;
- Women have formed self-help groups and become entrepreneurs;
- Such organizations have been strengthened by the IICT's introduction of the concept of fair trade practices through the work of British international consultant, Dr. Martin Kunjz, of Fair Trade Solutions.
- The above-mentioned intervention through UNDP Project through IICT has been exemplary with respect to introduction of social accountability not only in letter but also in spirit.
- In the current year, IICT has been able to build up capacity for approximately 500 artisans of whom about 300 are women.
- The areas of capacity built-up have been carpet weaving, designing and entrepreneurship.
- Most of the trainees could improve their Quality of Work Life.
- The greatest potential for future artisans can be found among women and marginal workers.

### **Extension of Capacity Building**

The sector needs formal capacity building to boost trainee morale and increase markets for their products. To this end, IICT could make available a Modular Employable Skills (MES) development programme in association with Director General of Employment & Training of India's Ministry of Labour and Employment.

### **The MES Development Programme**

## **Background**

The need for emphasis on the skill development, especially for the less educated, poor and out of school youth has been highlighted in various forums. The skill level and educational attainment of the work force determines the productivity, income levels and adaptability of the working class in a changing environment. A large percentage of population in India is living below the poverty line. One of the important causes is lower percentage of skilled persons in the workforce.

Skill development at present is taking place mostly in an informal way with people acquiring skills at the workplace when they help their parents, relatives and employers. Such individuals do not have a formal certificate and thus earn lower wages and are exploited by employers. They have come through informal system due to their families' socioeconomic circumstances and the necessity of earning a livelihood rather than attending a formal education and training programme. While their productivity is low, their contribution to the national GDP cannot be ignored. If the country can create a system of certification which not only recognizes their existing skills, but also provides further education and training, it will not only permit the workers to earn a decent living, but also contribute to the national economy by higher workforce productivity.

Another related problem to be tackled is large number of student drop-outs (about 63% of the student body).

## **The Framework for MES Skill Development**

Very few opportunities for skill development are available for school-age youth and existing workers. Most of the existing skill development programmes are long-term in nature. This was essential considering their educational, social and economical background. Poorly and less educated individuals cannot afford long-term training programmes due to opportunity costs, and often cannot meet high entry qualifications. Therefore, a new framework for skill development in the informal sector including carpet and textile manufacturing has been created by IICT to address the above mentioned problems. The key features of the new frame work for skill development are:

- Y Demand-driven short-term training courses based on modular employable skills  
decided in consultation with industry;
- Y Flexible delivery mechanisms (part-time, weekends, full-time);
- Y Different levels of programmes (foundation level as well as skill upgrades) to meet the demands of various target groups;
- Y Training to be provided by vocational training providers such as IICT or IICT-approved institutions;
- Y Optimum utilization of existing infrastructure to make training cost effective;
- Y Testing of skills of trainees by independent assessors who would not be involved  
in the conduct of the training programme;
- Y Testing and certification of prior learning skills;
- Y The essence of the scheme is in a certification regimen that will be nationally recognized  
by both the government agencies and industry/trade organizations.

The Short Term courses would be based on MES model.

### **The Concept of MES**

- Y Identifies a “minimum skills set,” which is sufficient to gain employment in the industry;
- Y Allows skills upgradation, multi-skilling, multi-entry and exit, vertical mobility and flexible life-long learning opportunities;
- Y Allows recognition of prior learning (effective certification of informally acquired skills);
- Y Permits the modules in a sector, when grouped together, to lead to a qualification equivalent to National Trade Certificate or higher.
- Y Could make available from level 1 to level 3 in different vocations depending upon the needs of the employer organizations.
- Y Would benefit different target groups such as:

- . / Workers seeking certification of their skills acquired informally;
- . / Workers seeking skills upgrades;
- . / Early school drop-outs and the unemployed.

### **Curriculum Development Process**

The following procedure should be used for developing course curricula:

- Y Identification of employable skills sets in a sector based on division of work in the labour market;
- Y Development of training modules corresponding to identified skills sets, so as to provide training for specific purposes;
- Y Organization of modules into a course matrix indicating vertical and horizontal mobility (the course matrix should depict pictorially the relation among various modules, prerequisites for higher level modules and the path to progress from one level to another);
- Y Development of detailed curricula and vetting by a trade committee and by the NCVT (close involvement of employers organizations, state governments, industry experts, vocational training providers and other stakeholders must be ensured at each stage).

### **Programme Duration**

Time taken to gain the qualification will vary according to the pathway, and will be kept very flexible for persons with different backgrounds and experience. Normal duration statements may appear in training programmes, which may be based on the content and requirements of a MES module.

### **Pathways to the Acquisition of Qualification:**

Access to the qualification could be through:

- an approved training programme; or

- a combination of an approved training programme plus recognition of prior learning including credit transfer; or
- The recognition of prior learning that provides evidence of the achievement of the competencies for the qualification.

### **Expected Impact of MES Development Programmes**

Implementation of MES development programmes across 2-3 million artisans engaged in the carpet trade would have enormous socio-economic impacts. The goals of socio-economic: improvement in the GDP, life expectancy, literacy, and level of employment could all be achieved through this intervention. Organizations like the ILO, WTO and United Nations through its various programmes can help make a beginning of such a project.



### **Plan for Accelerated Growth of the Carpet Sector**

India is famous for handmade carpet manufactured and exported from major belts as mentioned under:

- Uttar Pradesh (Bhadohi, Mirzapur, Varanasi, Agra)
- Rajasthan (Jodhpur, Bikaner)
- J & K (Jammu, Srinagar)
- Haryana (Panipat)
- Gujarat (Valsad)

These belts need to be geared up for enhancement in the world market share of carpets in general and hand knotted carpets in particular. Improvement in the socio-economics status of the trade in general and artisans community in particular would result.

To accomplish this, Public-Private-Partnership (P-P-P) and/or national government interventions are required. It is therefore pertinent to describe the prevailing manufacturing process, to identify specific areas that need attention and to provide a gap analysis to enable preparation of an action plan that can be implemented and monitored.

### **Manufacturing Process**

The manufacturing process includes key areas including:

- I. raw materials in fiber and or yarn form, dyes, chemicals, auxiliaries and ancillary materials;
- II. knotting or weaving or tufting;
- III. dyeing of yarn (wool, silk, etc.) in shades meeting design/naksha.
- IV. washing of carpets followed by drying;
- V. finishing including trimming, stretching, embossing, fringe knotting, etc.

### **Specific Areas Needing Attention**

Overall quality upgrading demands action in the following areas to be implemented by means of public-private-partnerships and/or Government of India (GOI) intervention through the 11<sup>th</sup> Five-Year Plan for the growth of India's carpet industry.

<b><u>Specific Areas</u></b>	<b><u>Mode of Intervention</u></b>
1. Raw Material	P-P-P
2. Common Facility Centre	P-P-P
3. Human Resource Development	GOI
4. Market Intelligence	P-P-P
5. Information Technology	P-P-P
6. Quality Culture	P-P-P
7. Infra Structure	GOI

### **Gap Analysis and Action Plan**

The prevailing shortcomings vis-à-vis the suggested strategy to meet growth targets are identified to support our views about technological and institutional requirements for the handicrafts sector and its wool/carpet/textile sub-sectors. This vision statement indicates specific areas which need governmental interventions.

### **Conclusion**

#### **Suggested Views-cum-Action Plan for Upgrading the Indian Carpet Industry**

<b>Suggestion Number</b>	<b>Specific Area</b>	<b>Prevailing Shortcomings</b>	<b>Views/Suggested Strategies to Overcome Shortcomings through Governmental Intervention</b>
1.	Raw Material	<ul style="list-style-type: none"> <li>• Non-availability of right quality at right time at right cost.</li> <li>• Inadequate knowledge of raw materials and product-client relationships.</li> <li>• Reduction in share of hand knotted and other value-added carpets.</li> </ul>	<ul style="list-style-type: none"> <li>• Creation of physical raw material bank covering key raw materials for major carpet belts.</li> <li>• Creation of knowledge bank/raw material service center.</li> <li>• Capacity building to manufacture and market high value-added carpets and similar items.</li> </ul>
2.	Common	<ul style="list-style-type: none"> <li>• Absence of culture</li> </ul>	<ul style="list-style-type: none"> <li>• To equip with developed</li> </ul>

	Facility Centre	for technological upgrades.	<p>version of looms, tools &amp; equipment to be funded by Ministry of Textiles, O/o DC (Handicrafts).</p> <p>/ Commercialization of new backing technique for tufted carpet for which patent has been filed by IICT.</p> <p>/ Adoption of IICT-developed cross bar horizontal loom, now validated and being patented.</p> <p>/ Adoption of new pile formation technology under development and being patented.</p> <p>/ Adoption of modern dyeing equipment for cost-effective and diversified dyed yarn.</p> <p>/ Adoption of modern carpet washing, drying and finishing system.</p> <p>/ Adoption of modern spinning system for inducing engineered carpet yarn.</p> <p>/ Creation of intellectual knowledge bank (IKB) wherein all relevant and related international journals /magazines for the fields of rural management, information technology, catalogues, colour and design forecasting etc., so that stakeholders can become members of IKB.</p> <p>/ Creation of National Design Bank (NDB) wherein all individual designers can become members; and the NDB, as a separate entity, would also have different national international buyers in its membership, leading to the creation of a niche market for Indian wool, carpet and textile products.</p> <p>/ Technical service and support to industry. IICT already has this portfolio, which can be further strengthened by permitting the creation of a pool</p>
--	-----------------	-----------------------------	---

			of consultants from various fields covering all regions of the country and abroad. This will help the sector to identify the challenges for the sector & deriving solution for the same.
3.	Human Resource Development	Lack of qualified and trained workers and opportunities for workers to improve skills.	<p>./ To encourage the industry to update the existing labour force and recruit trained and qualified workers by introducing both short-term and long-term projects to be funded by relevant organization.</p> <p>./ To cover the entire workforce of the sector through short-term training, MES development programmes, distance learning programmes and customized industry-driven skill development programmes. IICT is providing limited service in this area, which can be strengthened further.</p> <p>./ To cover the entire sector's labour force through knowledge integration programmes undertaken by local, regional, national and international level seminars and workshops.</p> <p>./ Total support to IICT to expand its activities with respect to creation of academic and research fields related to management, computer applications, etc., in general and the wool, carpet and textile sectors in particular.</p>
4.	Market Intelligence	Absence of relevant database for the sector nationally and internationally.	<p>Creation of a dynamic database.</p> <p>./ Information on raw material quality and prices paid by manufacturers at home country and abroad.</p> <p>./ Information on the importation of raw materials in terms of quality and price pertaining to importers and exporters.</p> <p>./ Information on export and import of final products covering</p>

			<p>the details of exporters and importers, product mix and price for the particular product mix.                  ./ Information on prevailing regional and national cost structures covering India &amp; competing countries.                  ./ SWOT analysis of the trade as a whole in regional /national / international context.</p>
5.	Information Technology	Absence of networking.	<ul style="list-style-type: none"> <li>• Creation of networking for the cluster as well as amongst the clusters of the region and country.</li> <li>./ Accessibility to related information for faster decision making and to avoid delay in supply in delivery.</li> <li>./ Adoption of software like Carpcost for research on cost and its control.</li> </ul>
6.	Quality Culture	Absence of brand image as quality culture is not evident.	<p>Creation of brand image.                  ./ Assured quality through testing and inspection of raw material, process and final product.                  ./ Benchmarking of above.                  ./ Publicity and retention of strengths identified through above.                  ./ Removal of identified weaknesses and exploitation of identified opportunities and removal of anticipated threats by executing short-term and long-term research projects to be funded by relevant agencies.                  ./ Diversification of product range (silk carpets, higher knots value, added finishing, etc.).                  ./ Become a reliable manufacturer and supplier through:                  I. creation/adoption of brands (quality labels such as Okotex, GUT, etc.).                  II. Adoption of relevant quality systems (e.g., ISO 9000, ISO 14000, SA 8000)</p>



7.	Infra Structure	<ul style="list-style-type: none"><li>• Absence of adequate and proper power supply, surface networking and transportation systems, and environment for quality life.</li></ul>	Industrial associations/council/relevant experts' opinions may be sought in this regard.
	Overall	<ul style="list-style-type: none"><li>• UVR for Indian Wool/Carpet/Textile products is significantly lower than competing countries.</li></ul>	Cost-benefit analysis through an approach paper should be prepared by any professional as a consultant and or turnkey implementing agency through funding by relevant agency.

The potential for socio-economic growth for the handmade carpet sector can be tapped. To do so, the International Monetary Fund, Asian Development Bank, World Bank, United Nation forum or similar relevant agencies need to be brought into picture to implement above mentioned suggested views. The impact expected from implementing the suggestions presented here would be manifold: improved growth in GDP, life expectancy, literacy, level of employment, etc.

### **About the Authors**

*Dr. Sandeep Srivastava* is a Ph.D. (Analytical Chemistry) from the Indian Institute of Technology, Delhi and M.Sc. (Inorganic Chemistry) from Hindu College, Delhi University, Delhi. Dr. Srivastava has been a civil servant since 1989 and is presently working as Additional Development Commissioner (Handicrafts) in the Office of the Development Commissioner (Handicrafts), an attached office with the Ministry of Textiles, a nodal office for the Handicrafts Sector at the national level. In his capacity as Additional Development Commissioner (Handicrafts), Dr. Srivastava is a Vice-chairman in the Indian Institute of Carpet Technology, Bhadohi (U.P.). During his posting as Additional Development Commissioner (Handicrafts), Ministry of Textiles he has visited the Philippines, New Zealand, Australia, China, Italy, USA, UK, and other countries as a

Team Leader representing the Government of India to deliberate with concerned overseas authorities/organizations for the purpose of ensuring higher export earnings for the country by way of enhancing acceptance for Indian Handicrafts in these high end markets. Apart from this, he is a keen researcher and has continued successfully to pursue research work in the field of polymer chemistry at the Indian Institute of Technology, Delhi, University of Delhi and Indian Institute of Technology, Roorkee. He has published research papers in various international and national journals. He was also nominated as a member of the working group on marketing for “National Bamboo Mission,” Ministry of Agriculture. Recently, Dr. Srivastava has participated in the 14th SAARC Summit in New Delhi and contributed to the formulation and institutionalization of a proposed SAARC Museum in Delhi.

**Dr. K.K. Goswami** is Ph.D (Technology), Calcutta University and Fellow of Institution of Engineers (India), C.Text, FTI of the Textile Institute, Manchester (UK). He is Professor, Director & Member Secretary of IICT with more than 30 years working experience in the field of industry, research, teaching and training. During this period, he has written more than 50 publications for various national and international journals and books on textiles and their allied industries. He was the Roster expert, International Trade Centre (UNCTAD/WTO), Geneva, Switzerland. He holds various key positions including Member of All India Handicrafts Board, Govt. of India; Convenor, Research Degree Committee and Member, Board of Studies; Paper setter, Examiner and Research Guide of Uttar Pradesh Technical University, Lucknow. He is credited to be the founder Director of the Indian Institute of Carpet Technology (IICT) under the Ministry of Textiles, Govt. of India and in making IICT truly functional in the interests of concerned stakeholders. He has worked as Principal Investigator for around 50 projects sponsored by various agencies. He is the inventor of a New Carpet Backing Technology (Snehabha) which has been considered a milestone in the history of handmade carpets and a Cost Calculation Software (CARPCOST) which has been successfully validated. He is expecting award of copyright & patent shortly. He is Editor as well as author of a chapter “Handmade Carpets” for a book entitled “Advances in Carpet Technology” by Woodhead Publishing, UK, to be completed shortly.

# 3

## EXECUTIVE SUMMARY

## EXECUTIVE SUMMARY

The executive committee of IICT dated 19.03.2012 resolved that IICT should have a futuristic plan with a proposal for consideration of SFC/EFC as appropriate.

The issue was regularly discussed in subsequent meetings of Executive Committee. In the meantime, Shri Virendra Singh Hon'ble Member of Parliament, Bhadohi vide letter No. 00089/78BDH/MP dated 27.08.2014 recommended to government for expansion of IICT to Indian School of Textiles of University level so that IICT can play its desired role of capacity building. As a follow up MP himself met the then DC(HC) on 25.02.2015 and subsequently as desired a concept note was submitted by Director, IICT to the then DC(HC) on 03.03.2015.

The issue of VIP reference and submitted concept note were discussed in detail in the Executive Committee Meeting dated 19.05.2015. The committee members expressed concerned about its viability. Hence advised IICT to submit a proposal to survey the feasibility under R&D scheme of DC(HC) to be carried involving consultants preferably from Dept. of Management Studies, IIT Delhi and Textile Technology Dept. IIT Delhi.

In accordance IICT submitted a proposal dated 10.06.2015. In response to the proposal O/o DC(HC) extended the grant dated 04.09.2015 for conducting "Feasibility study on up-gradation of IICT, Bhadohi to a national level Textile Institute" of university level with definite TOR.

As desired by E.C, a road map for the project was also submitted on 14.09.2015 for perusal of Director (HC), Vice-Chairman, IICT wherein Methodology, Action Plan and Time schedule was framed and same was discussed in detail in the O/o Dr. D.K.Banwet, Emeritus Professor, Dept. of Management Studies, IIT Delhi dated 15.09.2015.

Further a background notes along with draft DPR and other documents were shared with the consultants to facilitate further proceeding at their level. Thereafter, on 13.10.2015 draft TOR was sent to all the experts which was executed in legal paper on 18.10.2015 with clear cut TOR.

The draft DPR was presented to the then DC(HC) on 23.11.2015 wherein one of the engaged experts attended and briefed to the chair. The outcome of the meeting in the form of salient points are;

- Employability of M. Tech (Carpet & Textile Management) be ensured.
- Elements like entrepreneurship fashion, information technology, accounting, finance, management including performance and project management to be integrated to the existing B. Tech Course.

IICT also shared the views expressed by ASFA during his visit to IICT on .....for appropriate inclusion

Based on above background, consultants & field expert designed the template for survey and feedback. Draft DPR from IICT was also shared to facilitate integration with the feasibility report .

*The outcome in the form of integration and compilation* of the work done by the experts, field experts including input from IICT were discussed on 25.03.2016. The same was further discussed in presence of project leader, consultant, field expert, IICT Project Team on 29.03.2016.

The final report was prepared with consensus of all concerned on 30.03.2016. The salient features of the report are:

- Professors from IIT Delhi for the conceptual direction, time to time review, examination of documents, personal interaction and analysis of data were involved. The field experts from SMS, Varanasi and IICT Bhadohi including Director IICT as leader were also inducted to support consultants as per provision available. The activities were in compliance to TOR of government and emergent needs.
- Examination of DPR in terms of statutory requirements of Ministry for SFC/EFC compliance was ensured
- The examination of the revised cost estimate integrating identified additional elements, which worked to ~ 54 Cr (Non-recurring) and Rs. 15 Cr (recurring). DKT to give actual modified figure on 25.03.16
- The consultants also examined the target of revenue generation of 9.19 Cr, where recurring expenditure other than pay and allowance is 6.70 Cr. DKT to give actual modified figure on 25.03.16

- The up gradation of IICT integrating all desired elements in existing B. Tech Course including introducing M. Tech (Carpet & Textile Management) were found to be feasible and timely in view of required capacity building for the sector with due compliance to feedback. A draft curriculum for M. Tech in Carpet & Textile Management a unique course of its kind combining two engines: Technology and Management seems to be extremely potential for this sector. Thus capacity building including entrepreneurship targeted in the proposal is likely to promote Skill India and Make in India mandate of government of India to meet the need of rural folk and derive demographic dividend in higher end. Further it was felt that institute to focus on MES in all probable and potential modules of textiles in general and carpet and home textiles/ hand crafted in particular. There may be necessity to redesign the curriculum to make it unique type so that true terminal competency is achieved. More and more entrepreneurs are created who can have better livelihood instead of working as an artisan under a contractor with a paltry wage so that demography at BPL and APL type also derives benefit. The socio economic potential as already identified earlier can be exploited by the country.
- The investment for this up gradation over a period of 5 years or so is feasible since the same is at par with similar national level institutes where Rs. 5.00 lakhs/ annum/students is being spent on the recurring head. As for as IICT is concerned, the same expenditure is Rs. 5.01 lakhs/annum/students. The consultants are of the opinion that IICT will be able to self-sustainable w.r.t. recurring expenditure other than pay and allowances after this Phase III expansion considering IICT became functional in 2001, 20 years' time is required to reach this height and quite reasonable.
- The report emerges with the recommendation for the up gradation as per above. However, it was pointed out that proposed up gradation integrating so many elements and introducing one PG.Course to run successfully for five years under the this expansion plan without ignoring skill development and up gradation to create work force. Thereafter in the next phase the creation of University will be easier depending on the demonstrable success and need at that point of time. The IICT can strive to become a lead institute of the world as University to serve the world handmade carpet industry in particular and rest textiles in general to fulfil the desire of Shri Atal Bihari Vajpayee the then Prime Minister of India expressed during inauguration of 1stWorld conference on hand made carpets in November, 2003. The relevant quote is *“Towards this end, in India we have made a small beginning by setting up the*

*Indian Institute of Textiles and Carpet Technology recently in Bhadohi in Uttar Pradesh, which is famous for its carpet industry. New Zealand has come forward to join us in this endeavour by introducing a distance learning programme for skill upgradation. We shall be happy to offer this platform to any country and to the industry on a mutually agreed upon framework of cooperation”*

- The consultants are committed to be available for power point presentation in front of competent authority of O/o DC(HC)/Ministry of Textiles, Govt. Of India to clarify any question arises.
- In this exercise support of Director, IICT who led from front and behind both was taken besides from faculty/staffs/students of not only IICT but also from other national and international students /faculty/staffs as responded. Other respondents include employers and whosoever wanted to respond.

The certificate issued by consultants as statutory requirement signifies all above points as a testimony for the feasibility / viability of the proposed up gradation to create the base for conversion of IICT to a true relevant and referral University of its kind. The report is enclosed with all supporting documents including for financial implication.

# 4

## SURVEY REPORTS





## Feasibility Study for B.Tech (FAT) & M.Tech (TM)

A Research for Indian Institute of Carpet Technology, Bhadohi

**Feasibility Study**  
**to**  
**Evaluate the Relevance of**  
**B.Tech Course in Fashion and Apparel**  
**Technology**  
**&**  
**M.Tech in Textile Management**  
**for**  
**Indian Institute of Carpet Technology,**  
**Bhadohi**

Krishna Kant Bajpai  
School of Management Sciences  
Varanasi

## **Introduction:**

Indian Institute of Carpet Technology (IICT) the only of its kind in Asia, has been set up by Ministry of Textiles, Govt. of India to provide much needed support to Textile, Carpet and allied Industries. The Institute is affiliated to U.P. Technical University, Lucknow and is approved by A.I.C.T.E. The institute is also a member of I.S.T.E. and CII and recognized by Textile Institute, Manchester, UK. The main thrust areas of the Institute are A) Human Resource Development B) Design Creation and Development, C) Research & Development and D) Technical Support Services to the Industry.

IICT Bhadohi is conducting B.Tech. Course in Carpet and Textile Technology from the year 2001 and eight batches have come out successfully with a total of 209 graduates in the related trade. As per informal industry feedback there is a need for qualified professional in the field of Fashion and Apparel technology, because majority of them are using people as technical professional who do not have any formal education and have acquired skill by hands on experience or by on job training by seniors.

To assess the veracity of this hypothesis a study was instituted with the organizations in textile and fabric industry, involved in various business functions ranging from manufacturing fabric, to made up dress material, printing and trading etc.

**Problem Statement:** Will it be feasible to start B.Tech program in Fashion and Apparel Technology and M.Tech in Textile Management at IICT Bhadohi?

**Significance of the Problem (and historical background):** It is observed that Industries in Varanasi, Bhadohi and other parts of the country involved in manufacturing of fabric, apparel and other related products don't have formally trained professional, and the reason is primarily non-availability of appropriate technical manpower resources. This has resulted in many cases, underutilization of true potential because there is a vast difference in skilled personnel who have got just hands on training and qualified and trained professionals.

**Purpose:** The purpose of this study is to assess the requirement of qualified and trained professional in the field of Fashion and Apparel Technology and get an idea whether the demand supply gap is significant enough to suggest the need for an independent program on Fashion and Apparel Technology.

**Hypothesis:** There is a demand supply gap for qualified professionally trained professionals in Fashion and Fabric technology and apparel industry.

### **Assumptions:**

As the information was collected from the Owner / HR Head or Senior Manager authorized to speak to us. It was assumed that these people have complete and correct information and are sharing it with us correctly and honestly.

### **Limitation:**

The survey is not an extensive survey and does not cover the entire nation, therefore some of the observations may be area specific and may not hold true in other parts of the country where this survey is not instituted.

### **Review of Related Literature:**

The DPR was the guiding point to institute this survey. The observation mentioned help us form the basis to start the research and frame appropriate questions. Human Resource and Skill Requirement in textile sector (2022), a report by National Skill Development Corporation (NSDC), helped us identify the desired skill set for fashion, textile and fabric industry.

### **Design of Study:**

Sources of Data: The primary data is collected through personal and telephonic interviews and observations is recorded in a structured questionnaire.

Sampling Procedure: The questionnaire was implemented on the database from various trade organization like EUPEA, having members from fashion, fabric and apparel industry. The survey was implemented using convenience and random sampling on the database.

### **Methods and Instrument of Data Gathering:**

The Database from EUPEA was used to conduct random sample survey where every third organization on the list was interviewed, in case of non-availability or non-response, next organization on the list was taken up. In case of telephonic survey, convenience sampling was done.

### **Statistical Treatment:**

The data is categorized on the basis of Industry

## Analysis of Data

The survey was instituted through personal, telephonic and web-administered survey on 41 respondent, which comprised of organizations operating in the area of fashion and Fabric & Textile Industry. Out of 41 respondent 10 were from fashion industry and 31 from Fabric and textile industry.

Industry	Respondent	%
Fashion	10	24%
Fabric & Textiles	31	76%
Others	0	0%
TOTAL	41	

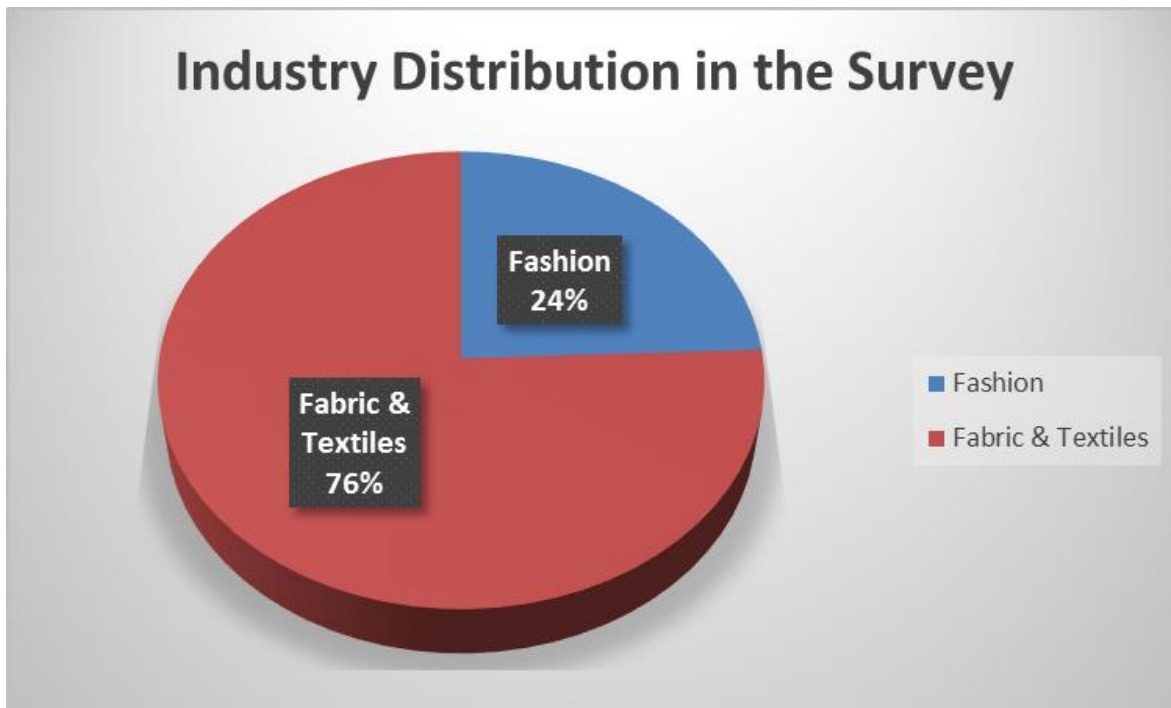

### Business Operation Distribution:

The Industry was further classified on the basis of business operations they were involved in, which were Designing, Printing (Textile and Fabric), Manufacturing Fabric, Manufacturing Apparel / Made-up and Trading (Both fabric and / or Apparel / Made-up).

Business Operation In-House	Respondent	%
Designing	10	24%
Printing	9	22%
Manufacturing Fabric	10	24%
Manufacturing Apparel/Made-up	2	5%
Trading	10	24%
TOTAL	41	

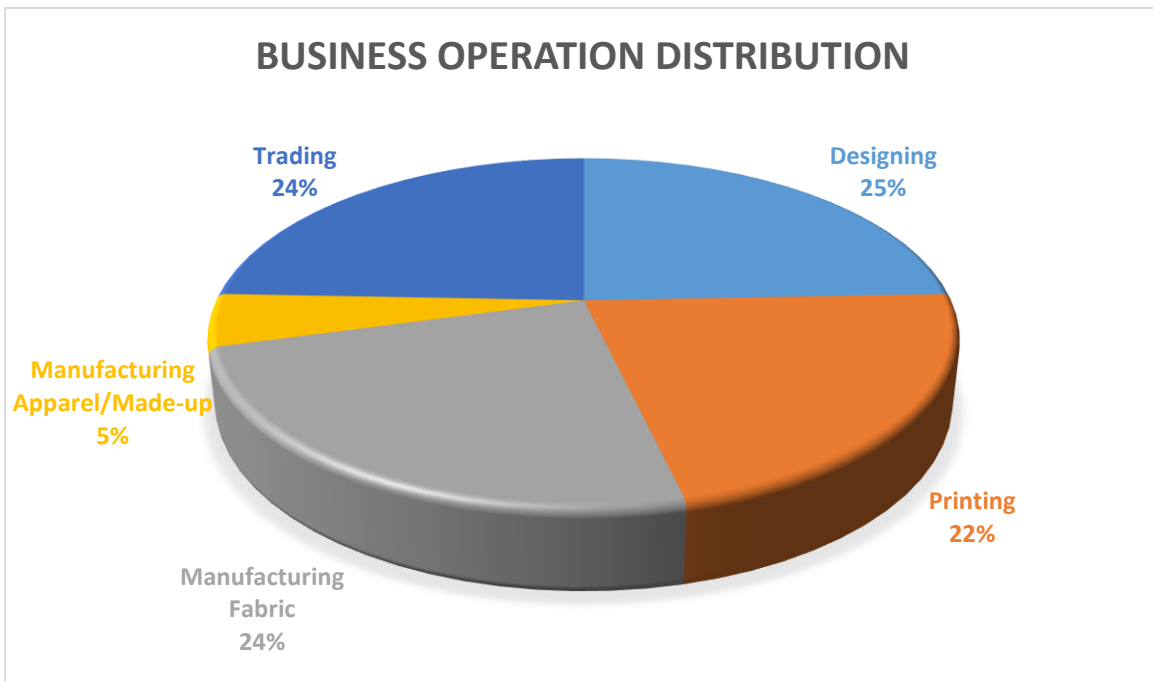

### Outsourced Business Operations:

Some respondents (32%) were involved in other related business operations also, which they outsourced. They procure order and then sublet to others. Major outsourced ventures were in the area of Printing and Fabric Manufacturing, which constituted 84% of outsourced work.

Business Operation Out Sourced		32%	
	Designing	1	8%
	Printing	6	46%
	Manufacturing Fabric	5	38%
	Manufacturing Apparel/Made-up	1	8%
	Trading	0	0%
	TOTAL	13	

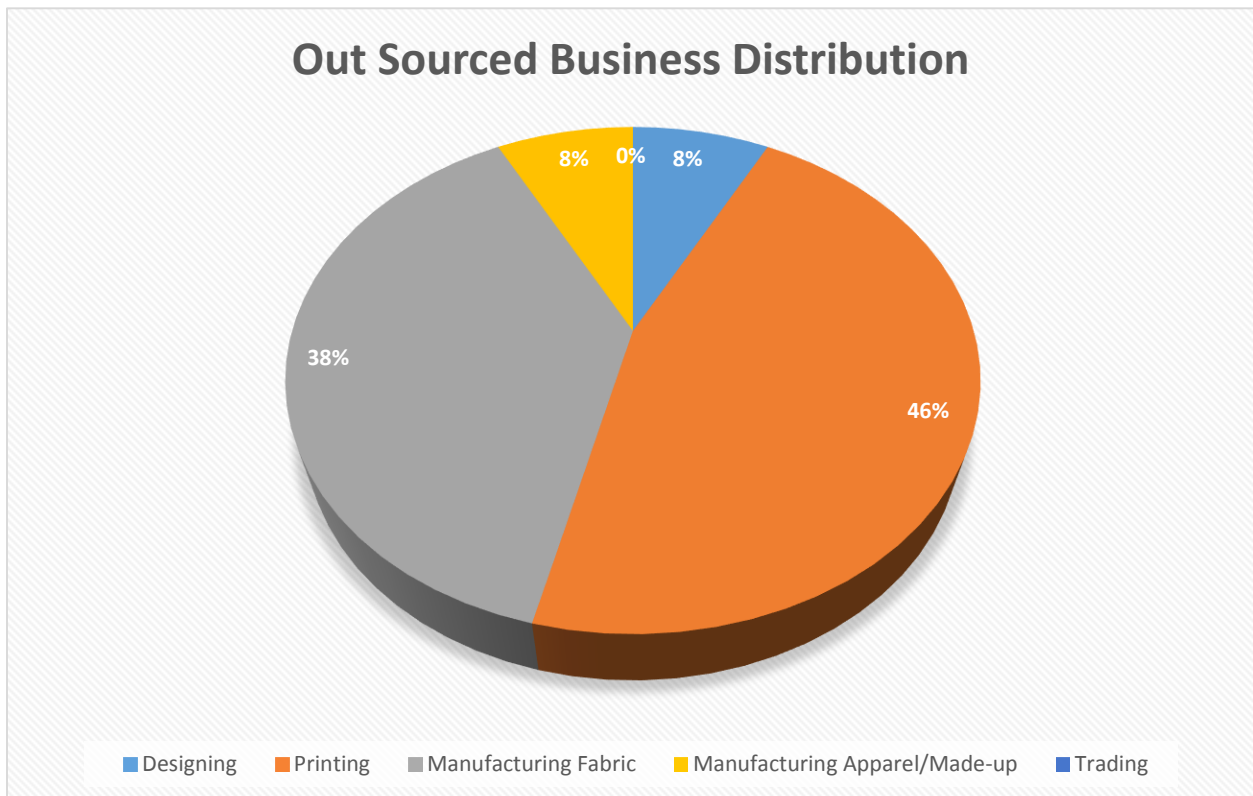

### Market Distribution:

49% respondents were catering to International and 51% catered to National Market, some respondent catered both, but we have considered the market which constituted bulk of their business.

Market	Respondent	%age
National	21	51%
Internatioanl	20	49%
	41	

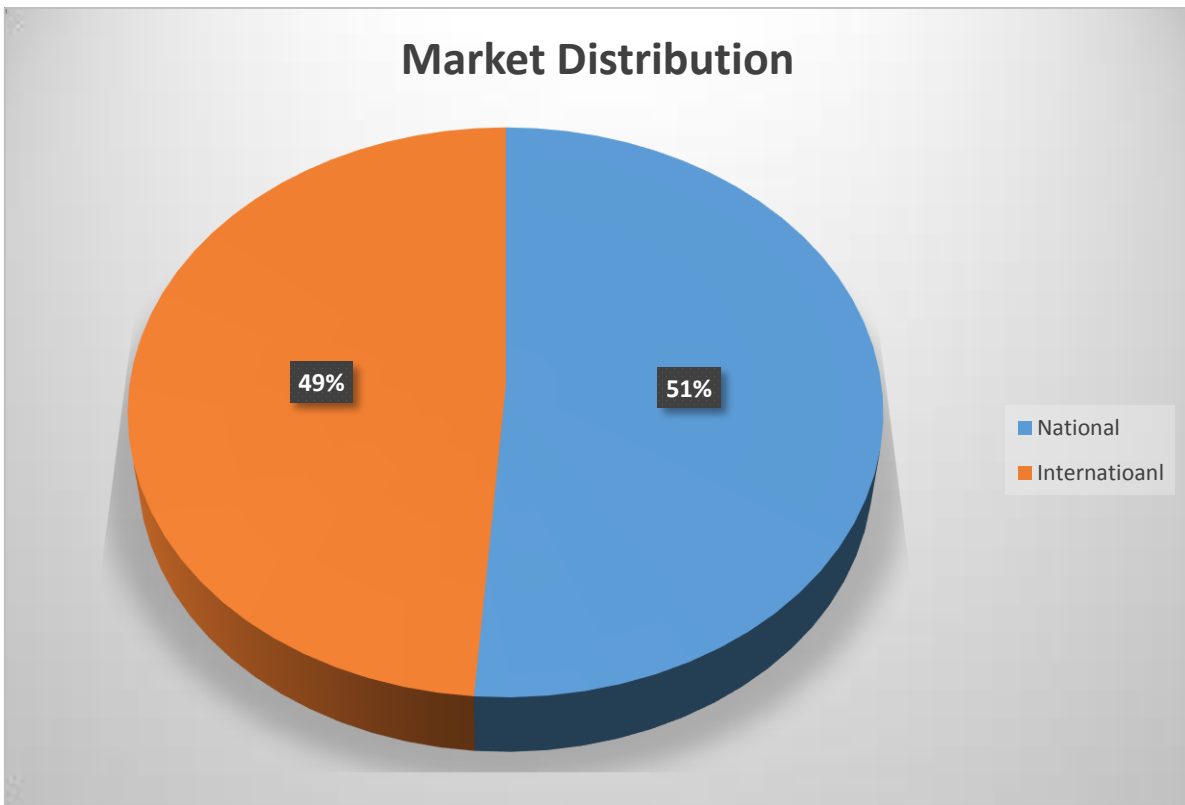



### Turnover Distribution

Financial Turnover	Respondent	%age
50 Lakh – 1 Cr.	14	34%
GT 1 Cr – 5 Cr.	11	27%
GT 5 Cr – 10 Cr	6	15%
GT 10 – 15 Cr.	10	24%
GT 15Cr	0	0%
TOTAL	41	

Out of selected lot, 61% had their turnover 5Cr. Or less and 24% fall between the ranges of 10 to 15 Cr.

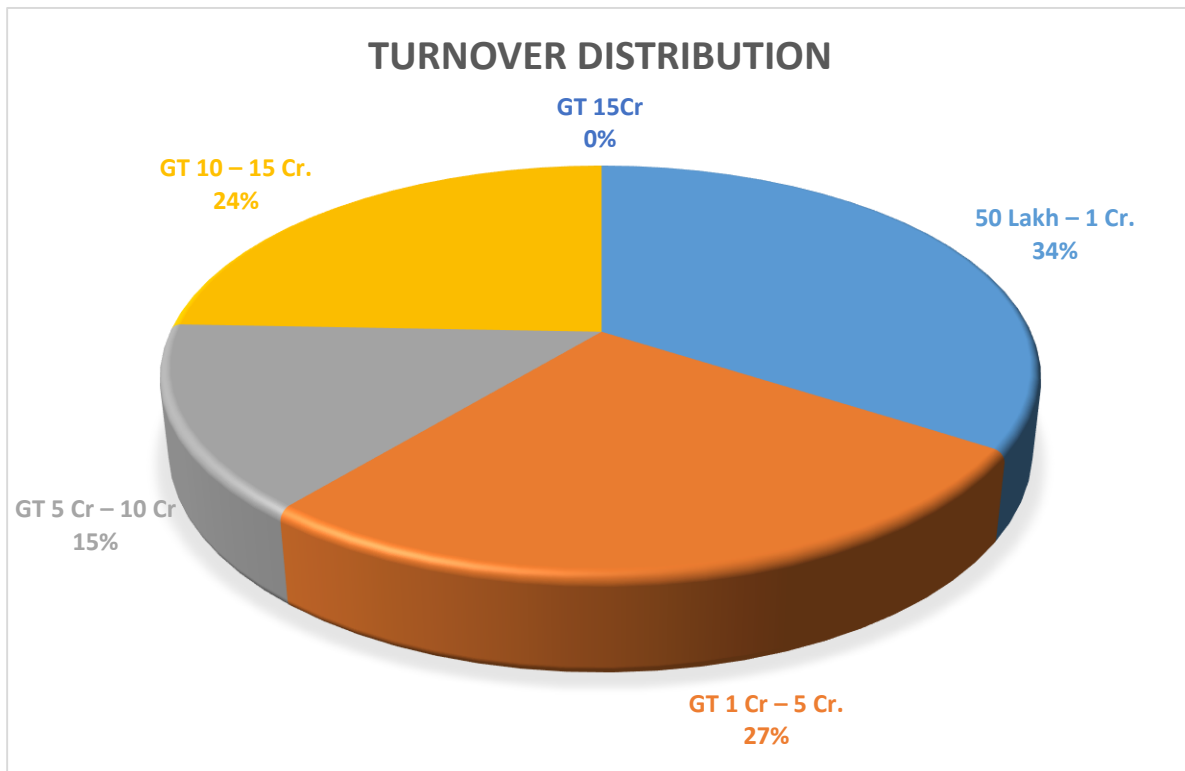

### Existing Manpower:

We found that Technical /Skilled Manpower constituted only 26% of total manpower which is significantly low keeping in view of technical nature of the industry.

Existing Manpower	Respondent	% age
Technical	114	26%
Non-Technical	333	74%
TOTAL	447	

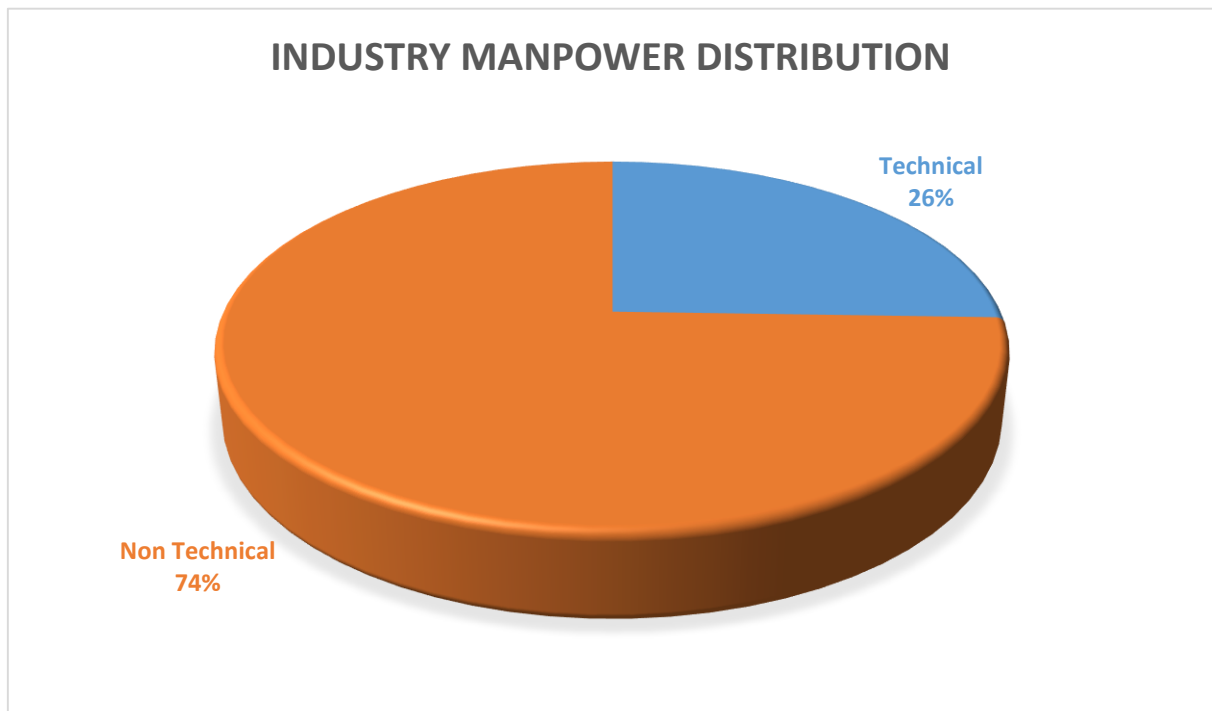

Row Labels	Sum of Existing_Manpower_Tech	Sum of Existing_Manpower_NTech
Fabric & Textile	94	303
Fashion	20	30
<b>Grand Total</b>	<b>114</b>	<b>333</b>

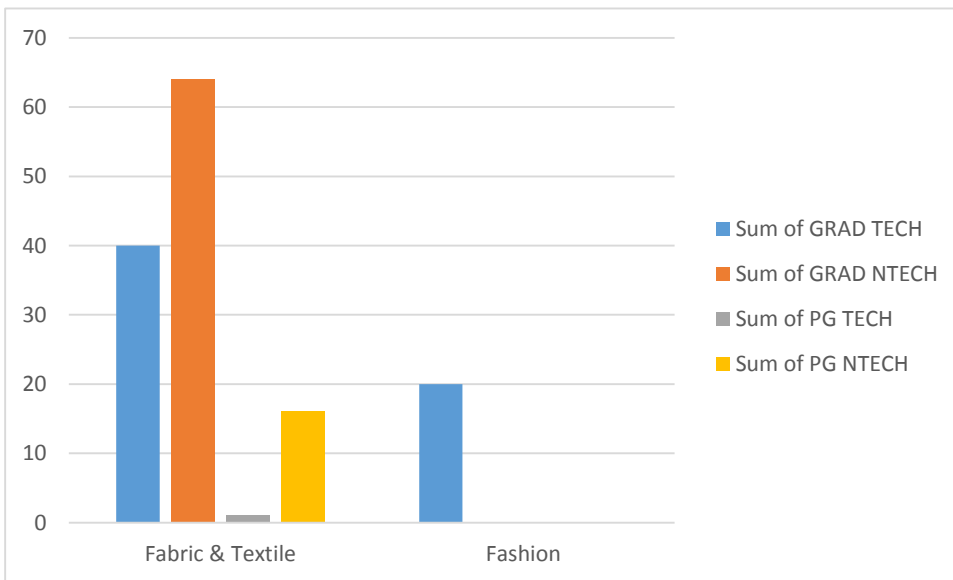

Row Labels	Sum of Existing_Manpower_Tech	Sum of Existing_Manpower_NTech
<b>Fabric &amp; Textile</b>	<b>94</b>	<b>303</b>
Mfg Apparel /Made up	5	16
Mfg Fabric	65	135
Printing	15	72
Trading	9	80
<b>Fashion</b>	<b>20</b>	<b>30</b>
Designing	20	30
<b>Grand Total</b>	<b>114</b>	<b>333</b>

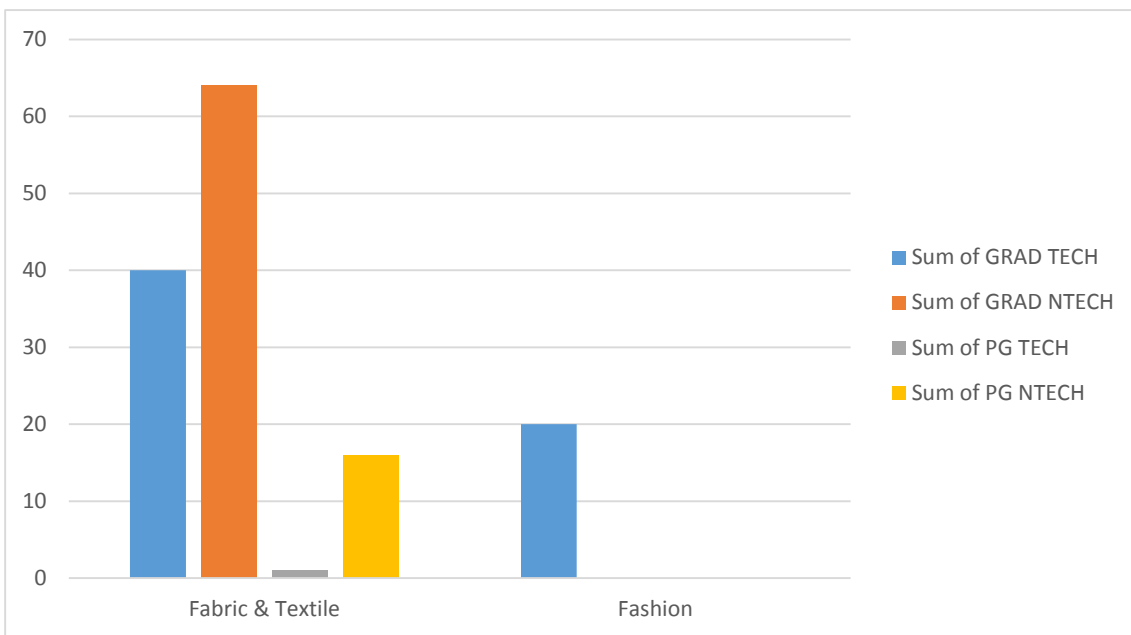

Row Labels	Sum of GRAD TECH	Sum of GRAD NTECH	Sum of PG TECH	Sum of PG NTECH
Fabric & Textile	40	64	1	16
Fashion	20	0	0	0
<b>Grand Total</b>	<b>60</b>	<b>64</b>	<b>1</b>	<b>16</b>

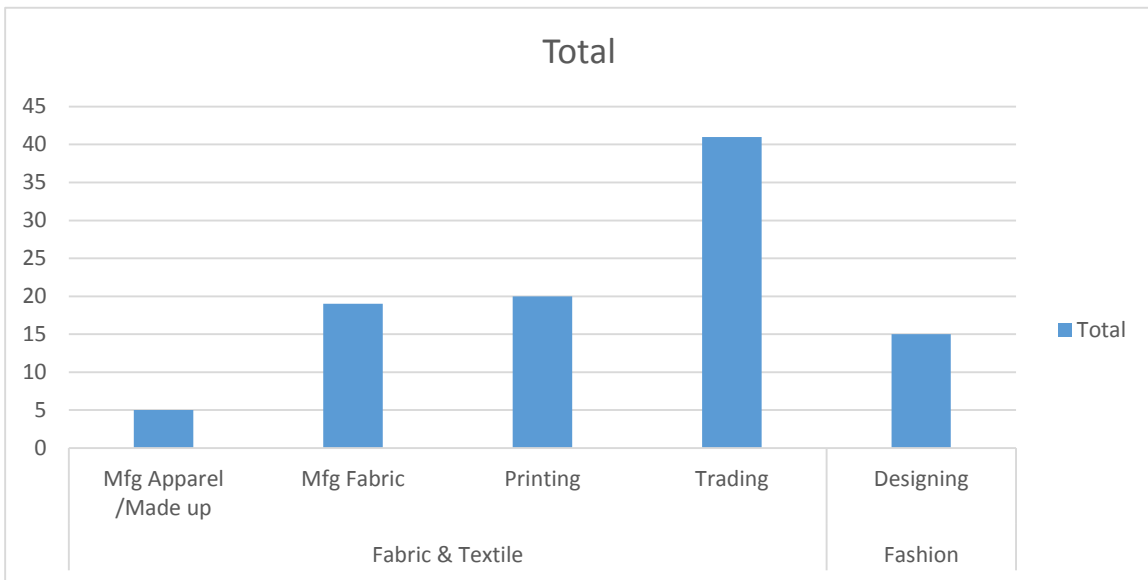

Row Labels	Sum of ITI	Sum of INTER	Sum of HS OR LESS
<b>Fabric &amp; Textile</b>	<b>0</b>	<b>111</b>	<b>131</b>
<b>0</b>	<b>0</b>	<b>43</b>	<b>21</b>
Mfg Apparel /Made up	0	3	1
Trading	0	40	20
<b>1</b>	<b>0</b>	<b>6</b>	<b>2</b>
Mfg Apparel /Made up	0	6	2
<b>2</b>	<b>0</b>	<b>12</b>	<b>33</b>
Printing	0	12	33
<b>3</b>	<b>0</b>	<b>25</b>	<b>40</b>
Mfg Fabric	0	25	40
<b>(blank)</b>	<b>0</b>	<b>25</b>	<b>35</b>
Mfg Fabric	0	25	35
<b>Fashion</b>	<b>0</b>	<b>10</b>	<b>10</b>
<b>1</b>	<b>0</b>	<b>10</b>	<b>10</b>
Designing	0	10	10
<b>Grand Total</b>	<b>0</b>	<b>121</b>	<b>141</b>

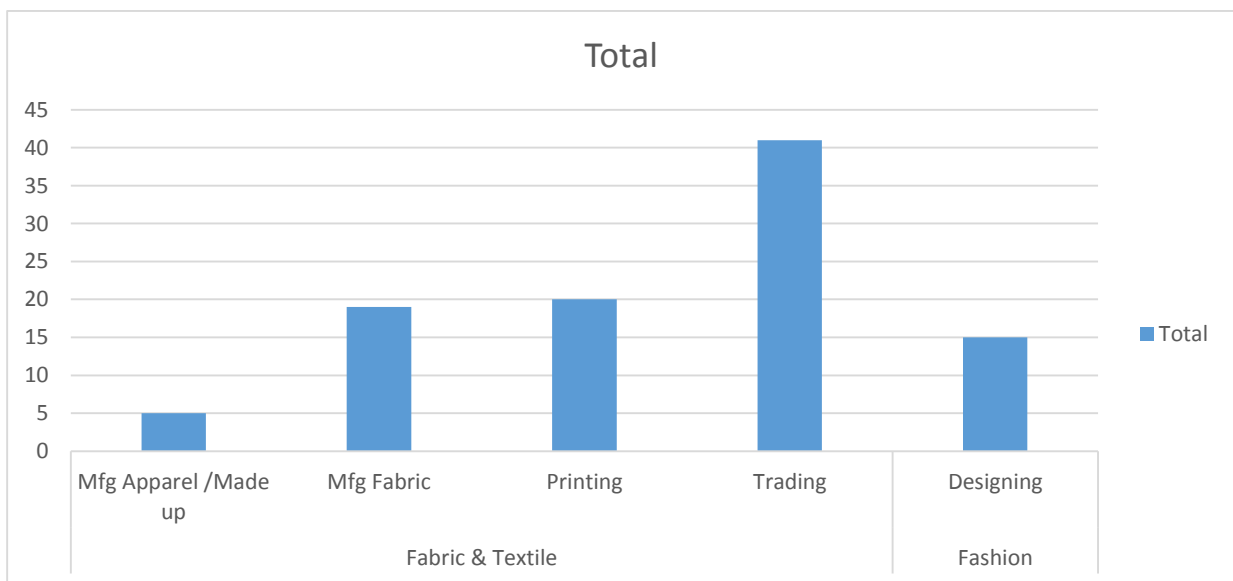

### Educational Competency

Manpower Competency		
PG (TECHNICAL)	1	0%
PG (NON-TECHNICAL)	16	4%
GRADUATE (TECHNICAL)	60	13%
GRADUATE (NON-TECHNICAL)	64	14%
ITI	0	0%
INTERMEDIATE	121	27%
HIGH SCHOOL OR LESS	141	32%
UNEDUCATED	44	10%
TOTAL	447	

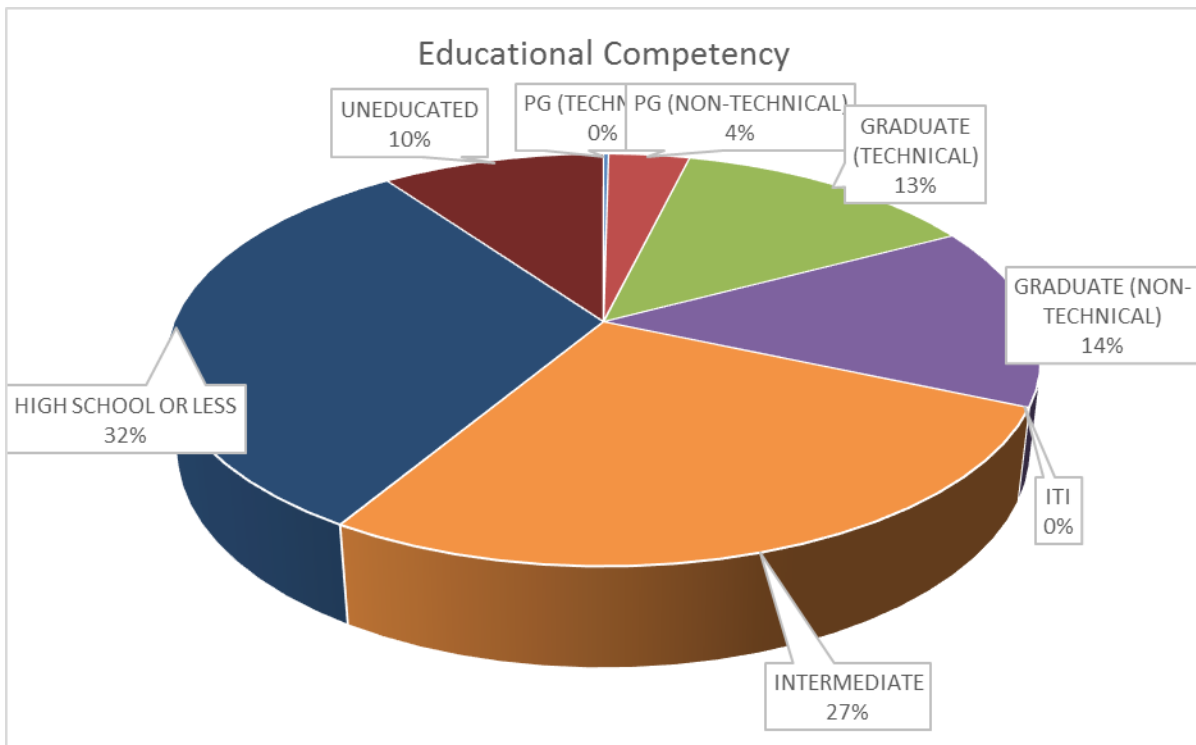

### Employee Turnover (Technical & Non-Technical) :

Employee Turnover is not a major issue as per the 73% respondents Technical Staff had less than 10% turnover and for Non-Technical staff 66% respondents felt it is between 10-15%.

EMPLOYEE TURNOVER TECHNICAL		
LT 10%	30	73%
10-15%	11	27%
GT 15-20%	0	0%
GT 20%	0	0%
TOTAL	41	

EMPLOYEE TURNOVER NON TECHNICAL		
LT 10%	14	34%
10-15%	27	66%
GT 15-20%	0	0%
GT 20%	0	0%
	41	

EMPLOYEE TURNOVER NUMBERS		
Technical		
	2012	30
	2011	30
	2010	47
Non-Technical		
	2012	73
	2011	42
	2010	77

EMPLOYEE RECRUITMENT NUMBERS		
Technical		
	2012	40
	2011	46
	2010	26
Non-Technical		
	2012	62
	2011	93
	2010	84



### Recruitment Method:

Only 5% of respondents opted Fashion Technology Institutes as source for recruitment. Majority depended on Industry or employee references.

RECRUITMENT METHOD	Respondent	%age
Placement Agency	0	0%
Advertise in Media	0	0%
Fashion Technology Institutes	2	5%
Industry Reference	28	68%
Employee Reference	11	27%
Other	0	0%
TOTAL	41	

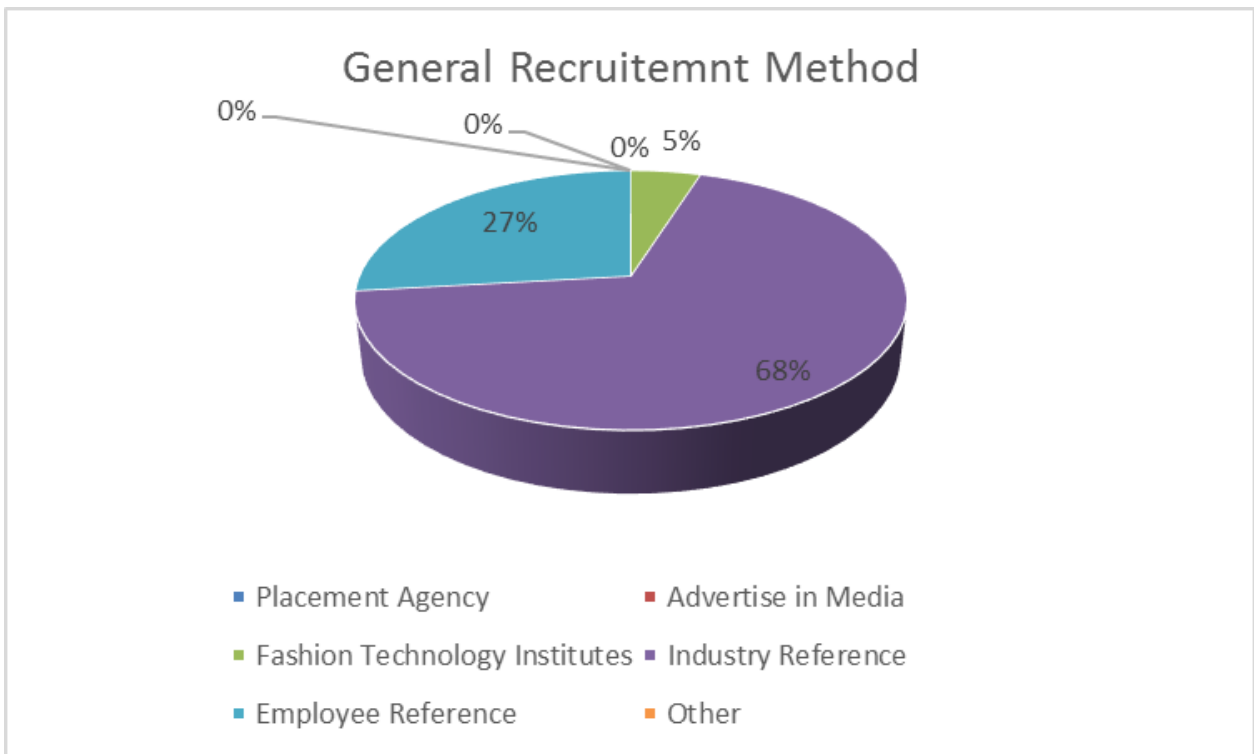

**Willingness to hire skilled manpower:**

73% respondents said YES emphatically when asked, if there is need for skilled manpower and out of 11 respondent who were not sure, 10 were involved in Trading and 1 was into manufacturing of Garments and Apparels.

Skilled Manpower Needed?			
Yes	30		73%
No	0		0%
Can't Say	11		27%
TOTAL	41		

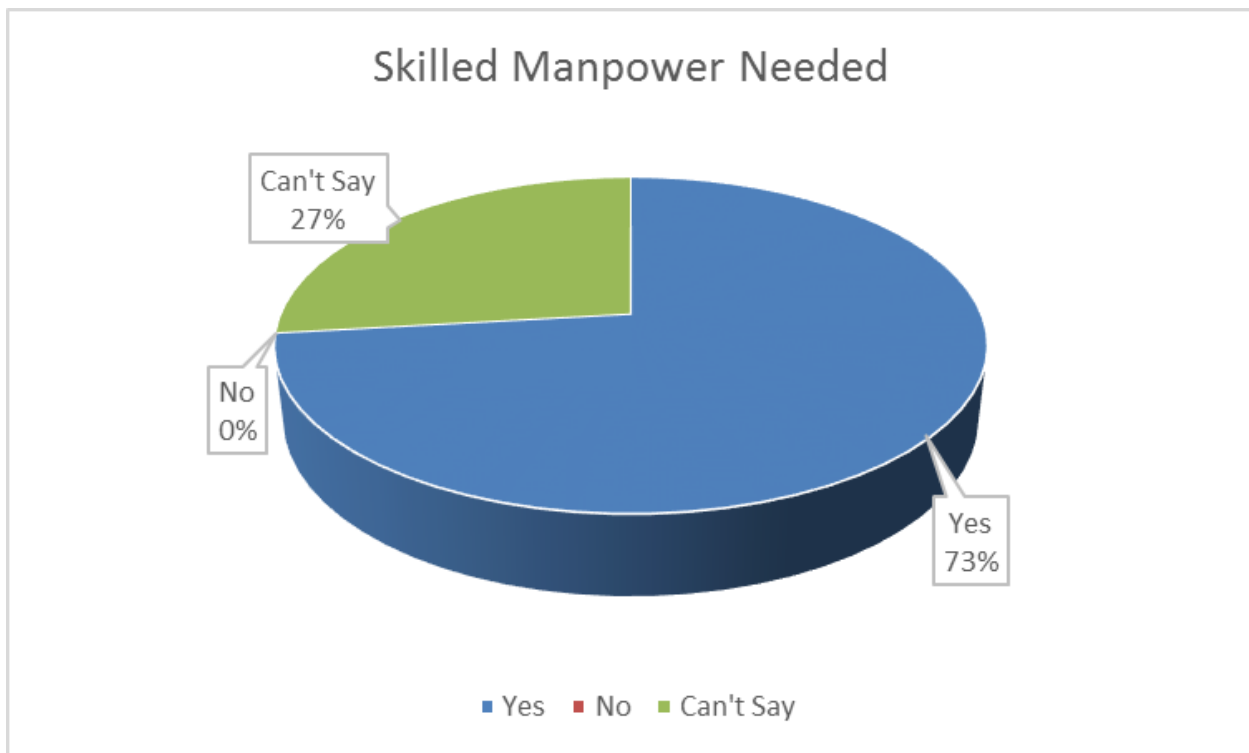

### Likelihood of Hiring Trained Professional:

Respondents were asked that if professionally trained skilled manpower is made available to them, what will be their willingness to hire them, 89% responded from likely to definitely, and 11% (9 Respondent) said they are unlikely or will not hire such professionals, as expected all these 9 respondent were into trading.

Likelihood of hiring Trained Professional		Respondent	%age
1	Definitely	8	20%
2	Most Likely	18	44%
3	Likely	6	15%
4	Not Likely	7	17%
5	Definitely Not	2	5%
	TOTAL	41	

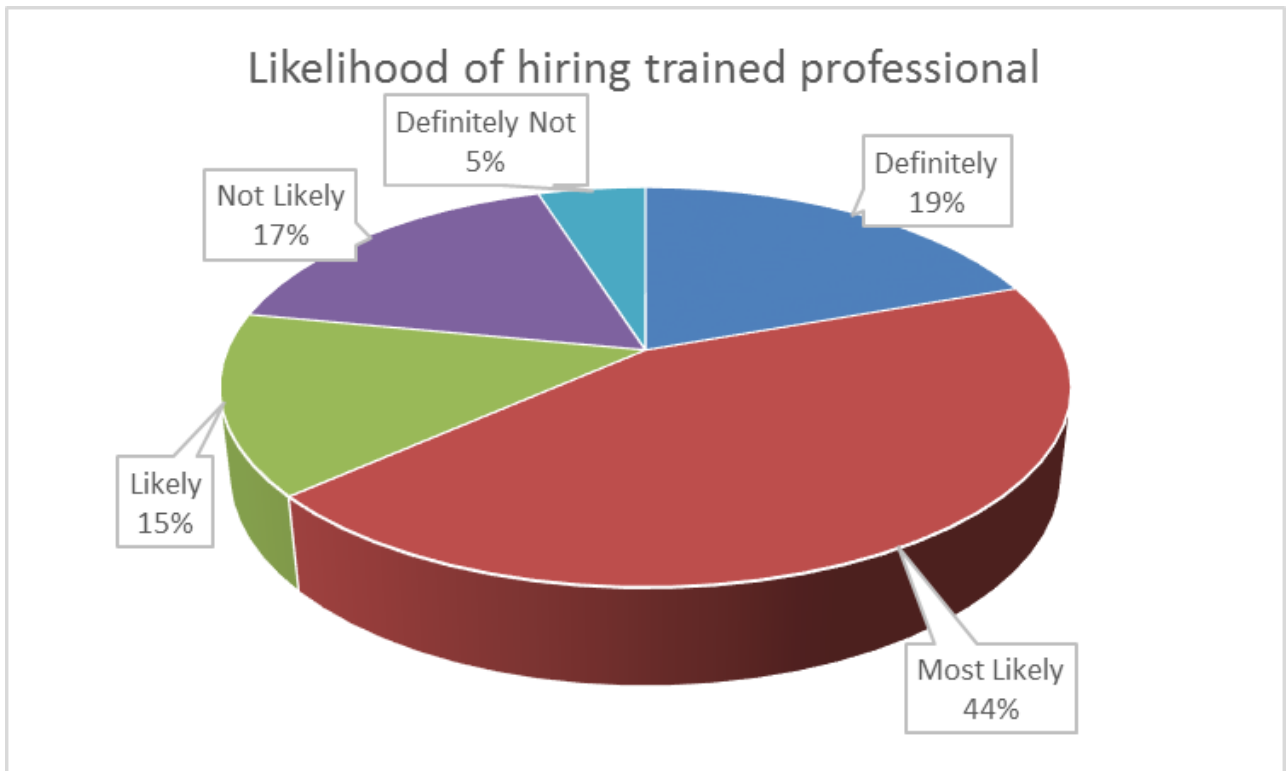

### Skill Set Preference:

Respondents were asked what skill set people they shall be needing for their organization in NEAR FUTURE, as follows:

S.No.	Skill	Level	Ranking
1	Procurement	Purchase Manager / Purchase Associate / Executive	
2	Merchandising	Sr./ Jr. Merchandiser/ Merchandiser Executive	
3	Design	Designer	
4	Production	Production Manager / Line Supervisor /Floor Supervisor/Operator	
5	Quality	Quality Control Executive	
6	Sales	Sales Manager / Executive	

Based on their responses, following skill set preference grid is designed

Skill Set	1	2	3	4	5	6	Preference
Procurement	0%	24%	24%	51%	0%	0%	4
Merchandising	0%	0%	24%	0%	76%	0%	5
Design	46%	29%	0%	0%	24%	0%	1
Production	29%	46%	0%	0%	0%	24%	2
Quality	0%	0%	51%	49%	0%	0%	3
Sales	24%	0%	0%	0%	0%	76%	6

Which places, Design, Production, Quality, Procurement, Merchandising and Sales in order of preference.

Preference Grade:

Skill Set	Preference
Design	1
Production	2
Quality	3
Procurement	4
Merchandising	5
Sales	6

## **Summary and Conclusions:**

The research was instituted to evaluate: will it be feasible to start B.Tech program in Fashion and Apparel Technology and M.Tech in Textile Management at IICT Bhadohi. The study started with the hypothesis that there is a demand supply gap for qualified professionally trained professionals in Fashion and Fabric technology and apparel industry.

## **Major Findings:**

There is lack of qualified professionals, though the industry is managing with whatever professionals are available but they would welcome, if qualified and trained professionals are made available. The top three desired skill sets are Design, Production and Quality. These findings are in congruence with the research hypothesis about demand-supply gap. **The findings confirmed to the facts stated in the DPR.**

## **Conclusion:**

Going by the research findings and market survey, it can safely be stated that it would be good for the industry if a professional program is launched to train students in the desired skill set.

## **Recommendations for Further Investigation:**

A more detailed and geographically diversified survey is needed to incorporate industry relevant content in course curriculum to bring out industry worthy professionals from the Institutes of higher education in the field of Fashion, Textile and Fabric Technology.

Indian Institute of Carpet Technology  
Chauri, Road, Bhadohi, Uttar Pradesh - 221401  
Tel 05414 225504  
Fax [Fax]  
www.iict.ac.in



# FEASIBILITY STUDY REPORT

FY 2015-16

*Upgradation of IICT, Bhadohi to a National Level Textile Institute of  
University Level*

# TABLE OF CONTENTS

## Contents

Executive Summary _____	1
Purpose of the project _____	1
Need for an institute of higher education in the field of textile / fashion technology _____	1
Introduction & Background _____	4
Study Methodology _____	9
sample identification and selection _____	9
Organizations approached _____	9
study _____	10
Questionnaire Format (Electronic) _____	12
Questionnaire Format (Physical) _____	13
Response Summary _____	14
SWOT STATEMENTS (IICT FACULTY , STAFF & students) _____	34
SWOT STATEMENTS (IICT FACULTY, STAFF & SUTDENTS) _____	42
Analysis and Recommendation: _____	49
Consultants _____	50

# EXECUTIVE SUMMARY

## Executive Summary

### PURPOSE OF THE PROJECT

This project was commissioned by Indian Institute of Carpet Technology, Bhadohi (henceforth referred to as IICT) to undertake a feasibility study on the possibility of upgrading IICT, which is presently running B.Tech. Program in Carpet Technology, to National Level Textile University level, offering postgraduate programs and research in textiles.

While conducting this project, the study team identified the following key issues.:

- Need for an independent institute of higher education in the field of Textile and / or Fashion Technology.
- Relevance of such an institution for research, innovation and job creation.
- Feasibility of upgrading IICT to such an institution.
- Feasibility of establishing such an institution at Bhadohi
- Feasibility Benchmark

The study was conducted amongst all stakeholders, who were either professional or had academic association with IICT or from the industry. The feedback was also taken from people belonging to non-textile /fashion organizations and institutes.

### NEED FOR AN INSTITUTE OF HIGHER EDUCATION IN THE FIELD OF TEXTILE / FASHION TECHNOLOGY

According to TOR, the need and relevance of the program for industry in particular and society at large should be ascertained, by interacting with all relevant stakeholders (Industry representatives and professionals, recruiters, exporters, IICT clients, students and alumni)

### THE RELEVANCE OF SUCH AN INSTITUTION TOWARDS, RESEARCH, INNOVATION AND JOB CREATION

Relevance of an institute of higher learning for research & innovation and being a source of quality job creation, was found out by consulting the various stakeholders as mentioned in previous paragraph.



# EXECUTIVE SUMMARY

More specifically the objective was to determine how suitable such an institution would fulfil the objective of providing services to the industry through research, innovation, which could possibly result in direct and indirect job creation. Also the study tried to assess the possibility of such an institution being revenue generator (as in the dairy industry) to support some or all the programs to be cost effective and self-sufficient.

## FEASIBILITY OF UPGRADING IICT

IICT being the only institute of its kind, has vast experience and rich intellectual capital and has been providing qualified engineers to the industry. As per the information provided by the institute it has over 300 alumni placed all over the globe. The study also evaluated the pros and cons of upgrading IICT to an institute of higher learning with additional facilities and infrastructure vis a vis establishing another new institute.

## FEASIBILITY OF ESTABLISHING SUCH AN INSTITUTION AT BHADOHI

IICT was established in Bhadohi in 2001, as it is one of the main centers of woolen carpets in the country with annual turnover of Rs. 1000 Cr. Since as such institution would obviously attract people from all over the developing world, the study looked into the locational appropriateness of the proposed institute in Bhadohi.

## FEASIBILITY BENCHMARK

The procedural and regulatory requirements for the establishment of an institute at the university level are:

Campus location, infrastructure and course profile.

Consideration of industrial relevance and placement possibilities.

Catchment area of students for proposed institution (upgraded)

## ASSESSMENT AND RECOMMENDATIONS

Capacity building in regards to developing teaching expertise, faculty competency building and availability of competent faculty will take some time, and has to be evolutionary rather than instant. Though there is a need for professionals having more specialized knowledge and expertise, which can be given by an institute of higher learning having enough facilities for research and development. IICT has been doing many R&D activities for the industry and has also few patents in its name, which are

# EXECUTIVE SUMMARY

appreciated by the industry and are being used by it. The design bank established by IICT is also doing good. Therefore, we trust that IICT may be upgraded to the level of a university in due course of time.

Prof. D.K. Banwet  
Emeritus Professor  
Dept. of Management Studies, IIT  
Delhi  
Currently Vice Chancellor, UEM  
Kolkata

Dr. R. Chattopadhyay  
Professor,  
Dept. of Textile Technology,  
IIT, Delhi  
Ex Prof I/C Planning IITD

Krishna Kant Bajpai  
Associate Professor,  
Faculty of Management Studies,  
School of Management Sciences,  
Varanasi

March 30, 2016

# INTRODUCTION & BACKGROUND

## Introduction & Background

### OVERVIEW OF TEXTILE INDUSTRY\*<sup>i</sup>

India is one of the world's largest producers of textiles and garments. Abundant availability of raw materials such as cotton, wool, silk and jute as well as skilled workforce have made the country a sourcing hub. It is the world's second largest producer of textiles and garments. The

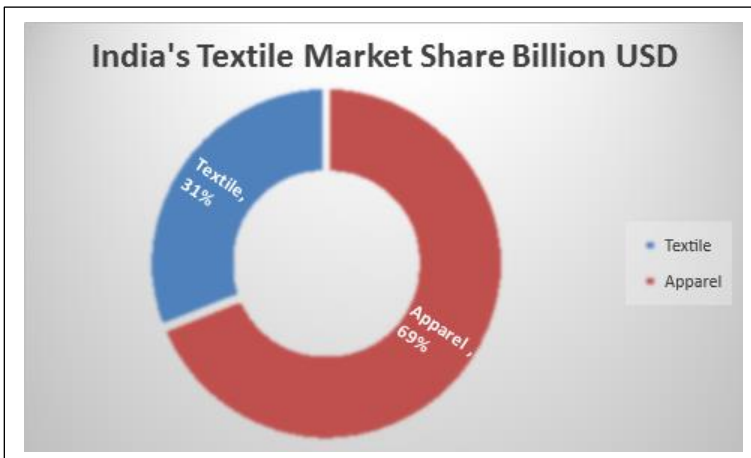

Indian textiles industry accounts for about 24% of the world's spindle capacity and eight per cent of global rotor capacity. The potential size of the Indian textiles and apparel industry is expected to reach US\$ 223 billion in 2021.

The textile industry has made a major contribution to the national economy in terms of direct and indirect employment generation and net foreign exchange

earnings. The sector contributes about 14% to industrial production, 4% to the gross domestic product (GDP) and 27% to the country's foreign exchange inflows. It provides direct employment to over 45 million people. The textiles sector is the second largest provider of employment after agriculture. Thus, the growth and all round development of this industry has a direct bearing on the improvement of India's economy.

India has overtaken Italy, Germany and Bangladesh to emerge as the world's second largest textile exporter. India's share in Global Textiles increased by 17.5% in 2013 compared to 2012. Textiles exports from India will touch US\$ 300 billion by the year 2024-25.

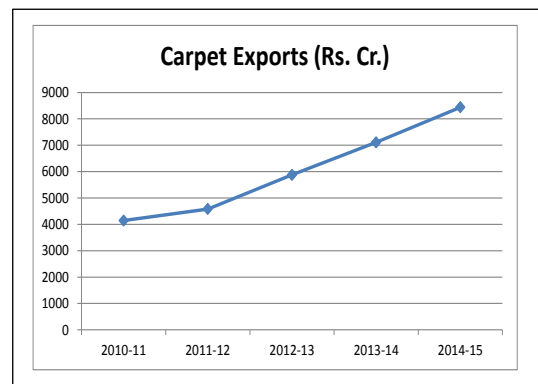

In 2012, apparel had a share of 69% of the overall market; textiles contribute the remaining 31 per cent.

# INTRODUCTION & BACKGROUND

## MARKET SIZE

The Indian textiles industry, currently estimated at around US \$108 billion, is expected to reach US\$ 141 billion by 2021. The industry is the second largest employer after agriculture, providing direct employment to over 45 million and 60 million people indirectly. The Indian Textile Industry contributes approximately 5% of GDP, and 14 % to overall Index of Industrial Production (IIP). The Indian textile industry has the potential to grow five fold over the next ten years to touch US\$ 500 billion mark on the back of growing demand for polyester fabric. The US\$ 500 billion market figure consists of domestic sales of US\$ 315 billion and exports of US\$185 billion. The current industry size comprises domestic market of US\$ 68 billion and exports of US\$ 40 billion.

The export of carpets is steadily increasing, attaining a growth of 204% in 5 years period starting 2010-11.

Apparel exports from India have registered a growth of 17.6% in the period April – September 2014 over the same period in the previous year.

## CHALLENGES AND FUTURE PROSPECTS

### Challenges faced by the Indian Textile Industry

In spite of immense factor fueling the growth of the Indian textile industry, there are certain challenges, faced by the country in terms of scarcity of trained manpower, escalating energy costs, high transportation costs, obsolete labor laws, low level of technology, and lack of economies of scale.

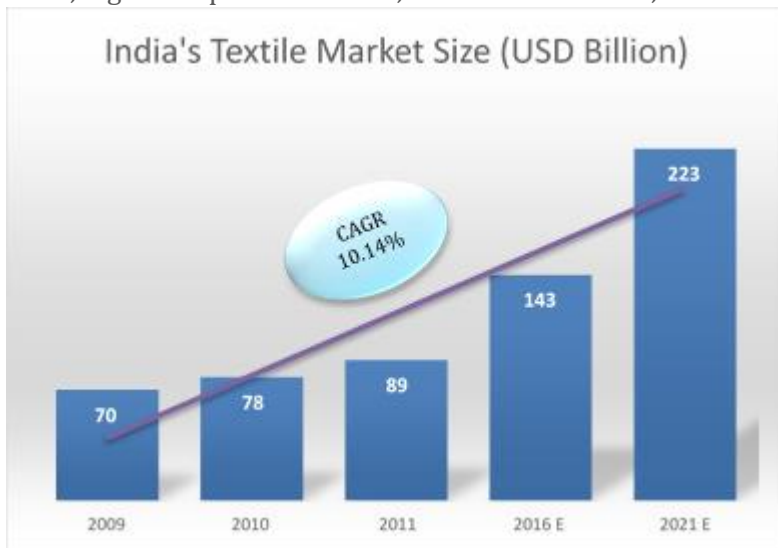

### Future Prospects

The Indian textile industry is set for strong growth, buoyed by both strong domestic consumption as well as export demand. The industry is expected to reach US\$220 billion by 2020.

With consumption and disposable income on the rise, the retail sector has experienced

# INTRODUCTION & BACKGROUND

a rapid growth in the past decade with several international players like Marks & Spencer, Guess and Next having entered the Indian market. The organized apparel segment is expected to grow at a compound annual growth rate (CAGR) of more than 13 per cent over a 10-year period.

## **Growth Drivers**

**The various drivers are stated below:**

- Rising per capita income, favorable demographics and a shift in preference for branded products.
- Favorable trade policies and superior quality.
- Increase in domestic demand.
- Pointed and favorable policies instituted by the government.
- With consumerism and rise in disposable income.
- Changing lifestyles and increased demand for quality products.

## THE CARPET AND TEXTILE INDUSTRY

In today's fashion scenario, textiles play an important role as costumes reflect ones' personality. The Textile industry not only includes woven, knitted or printed fabrics used for making clothes but also includes materials used for furnishing, upholstery, carpets, lace, etc. The production of this enormous variety of textiles creates the need for a career in Textile Engineering. Textile engineering technology deals with the production of fibers to manufacturing of textiles and products. Textile engineers can also find attractive opportunities in textile mills, export houses, knitwear manufacturing units, textile dyeing and garment industry, government organization and other allied industry or organizations using textile products. .

This field of engineering draws inputs from various other branches of engineering like chemical, instrumentation, computer, structural, electronic and mechanical engineering. Textile technology/Engineering deals with the application of scientific and engineering principles to the design and control of all aspects of fiber, textile and apparel processes, its products and machinery. These include natural and man-made materials, interaction of materials with machines, safety and health, energy conservation, and waste and pollution control. There is wide scope for research in this area as the industry demands the need to improve currently available products and develop new ones.

# INTRODUCTION & BACKGROUND

Textiles are utilized for innumerable purposes other than the manufacturing of garments. They are used in the manufacturing of carpets and furnishing like bed sheets and bed covers, quilts, table cloth, curtains and towels, etc. It is also used for rags and dusters, tents and nets, kites, parachutes, etc. Textiles have industrial uses as well. They are incorporated in firefighting suits, shuttle space suit, in carbon fiber composite rocket exhausts, and even in nose cones for NASA. According to its usage and texture, textiles are classified as Technical Textiles- made of zinc oxide and nanowires which enable protection from heat and radiation. Examples of Technical Textiles are protective clothing like firefighting suits, those designed especially for astronauts.

A large number of government-sponsored and private silk, handlooms, jute, khadi, and craft development organizations need textile technology experts. One with a degree in textile engineering can work as operations trainee, technical services assistant in a textile plant, process engineer, assistant designer in a design studio, quality control supervisor, sales in charge, fabric development executive, process improvement engineer, etc. Graduates are recruited in large numbers by textile giants like Arvind Mills Ltd., Bombay Dyeing, Raymond's, Fabindia, Grasim Industries, JCT Limited, Lakshmi Mills, Mysore Silk Factory, etc. It combines the principles of engineering with specific knowledge of textile equipment and processes.

**Medical Textiles** - Besides gauze and bandage, textiles are also being used as sutures, orthopedic implants, vascular grafts, artificial ligaments, artificial tendons, heart valves and even as artificial skins. Recent advances in medical textiles has led it to be used as extracorporeal devices which include artificial kidney, artificial liver, mechanical lungs, etc. New materials are finding specialized applications like antimicrobial and antifungal fibers and additives used in barrier fabrics, abdominal post-operative binders, applications in neurodermatitis treatment and various other wound management and surgical treatments.

**Agro textiles** – These are used to protect the farmers and Agricultural Engineers from the adverse effects of soil and pollution.

**Geo-textiles** – These are used for road construction, river embankment protection, erosion control etc.

The economic scope and importance of technical textiles extends far beyond the textile industry itself and has an impact upon just about every sphere of human activity. Textile Engineering is therefore very important for the development of technology for the benefit of the society.

## EDUCATIONAL / CAREER OPPORTUNITIES

# INTRODUCTION & BACKGROUND

There are several engineering colleges/polytechnics/universities in India that offer programs in Textile engineering / technology. The basic eligibility criteria for B. E / B. Tech in Textile Engineering is 10+2 or equivalent examination with Physics, Chemistry, Mathematics with a fairly high percentage of marks in the aggregate. After pursuing bachelor's degree (B.E/B Tech), one can go for a post graduate degree; i.e. M.E/ M.Tech. and after that one can take up the Ph.D. degree. Indian Institute of Technology, Delhi is a prominent institute in the field offering B.Tech/M.Tech/Ph.D. programs in Textile Technology.

Textile engineers are absorbed in cotton yarn manufacturing corporations, and research laboratories. Manufacturing units of technical textiles like agro textiles and medical textiles is another area of employment where textile engineers are in great demand. Another option is self-employment, i.e. to start own textile manufacturing unit. Teaching and research is another option for textile degree holders. They can work as lectures in universities/ institutes teaching this subject. They can develop new fiber or even new techniques for treatment of fibers.

## Study Methodology

### SAMPLE IDENTIFICATION AND SELECTION

Stratified sampling procedure was followed. The stakeholders were categorized into following 12 groups –

- a. Current /Ex-Student
- b. Current /Ex-Employee
- c. Guest / Invitees (Faculty and Lecturers)
- d. Industry Client of IICT (Consultancy or other services)
- e. Employers of IICT graduates
- f. Academic institutions in the field of Carpet /Textile/Fashion/Allied areas
- g. Industry members in the field of Carpet /Textile /Fashion/Allied areas
- h. Other Industries
- i. Other Academic Institutions
- j. Trade bodies / organizations
- k. Current /Ex-suppliers / Contractors (Service)
- l. Current /Ex-suppliers / Contractors (Equipment)

### ORGANIZATIONS APPROACHED

- a. All India Carpet Manufacturers Association
  - b. Rajasthan Carpet Manufactures & Exporters Association
  - c. Agra Carpet Manufacturers Association
  - d. Eastern U.P. Exporters Association
  - e. Indian Floor Covering Exporters Association
  - f. All India Carpet Exporters Association
  - g. The J & K Carpet Manufactures & Exporters Organization
  - h. Rajasthan Carpet and Woolen Product Development Society
  - i. Haryana Carpet Manufacturers Association
  - j. The Panipat Exporters Association
  - k. Indian Institute of Carpet Technology, Srinagar
  - l. Eastern UP Exporters Association
  - m. Kaleen Bandhu,
- Apart from these organization convenience sampling was executed in many colleges, institutions and organizations.



# STUDY METHODOLOGY

## STUDY

The consultants' team from IIT Delhi, comprising Prof. D.K. Banwet (Emeritus Professor) and Prof. R. Chattopadhyay (Textile Department) were commissioned to perform a feasibility study of whether or not the existing IICT could be upgraded to the level of a University.

The methodology adopted was to conduct a surprise mini workshop at IICT Bhadohi, for the faculty and staff in the form of a SWOT (Strengths, Weaknesses, Opportunities and Threats) analysis. The workshop was held impromptu and some resistance to give free and frank opinion was voiced. The moderator of the workshop dispelled such fears orally. No names were to be written. This was the important set of data collected to understand the feelings - both positive and negative of the participants.

Yet another important component of data acquisition was through a written questionnaire administered to various stakeholders.

Structured questionnaire was conceptualized, designed and mailed to respondents, which were to be electronically filled and sent back to us. This has facilitated the international coverage of this study, we had respondents from UK, Australia, South Africa and other countries apart from other cities in the country.

Questionnaire was also distributed at various conferences and seminars where the target audience was conveniently available. Physical questionnaire and interviews were conducted from the industrialists, exporters and all such respondents who were otherwise didn't find it convenient to fill and respond on the on line questionnaire.

There was a focus group discussion conducted to have a SWAT analysis as per the objective of the study, at the outset of the study independently with the faculties, staff and students. The group was told about the objective of the study without giving them any lead on inclination towards the objective to keep the discussion bias free, also to ensure that there is no bias created by any participant's opinion, the participants were asked to write their views in the heads of Strength, Weakness, Opportunity and Threat on a piece of paper without disclosing their identities. This removed any bias arising out of fear or favor intentions.

Electronic questionnaire was also made available on the institute's website [www.iict.ac.in](http://www.iict.ac.in)

# STUDY METHODOLOGY

The demographics of the respondents

The respondents were chosen from cross section of stakeholders.

<b>Respondent Age profile</b>	<b>Years</b>
Average Age of Respondents	28
Oldest Respondent	79
Youngest Respondent	17
Mean Age of respondents	26

The respondents (Other than current students of any institution) varied in professional experience,

<b>Respondent Professional Experience profile</b>	<b>Years</b>
Average Experience	20
Most Experienced	62
Least Experienced	3

# QUESTIONNAIRE FORMAT (ELECTRONIC)

## Questionnaire Format (Electronic)

### Questionnaire for Feasibility study on up-gradation of IICT, Bhadohi To a National Level Textile Institute of the University Level

(Kindly save the file after filling in your responses and mail the saved file to us.)

- Are you aware of any textile University in India or abroad? Choose an item.
- Are you aware about IICT (Indian Institute of Carpet Technology, Bhadohi) Choose an item.
- If yes have you got a chance to interact / associate with IICT. Choose an item.
- If Yes in what capacity have you interacted with IICT (You can choose more than one option)
  - Current /Ex Student
  - Current Ex/Employee
  - Guest /Invitee
  - Industry Client of IICT (Consultancy or other Services
  - Employer of IICT graduates
  - Academic Institution in the field of Carpet /Textile/Fashion/Allied Areas
  - Industry in the field of Carpet / Textile /Fashion /Allied areas
  - Other Industries
  - Other Academic Institutions
  - Trade bodies / Organizations
  - Current /Ex-Supplier /Contractor (Service)
  - Current /Ex-Supplier/Contractor (Equipment)
- How do you perceive IICT's contribution towards the industry and society at large  
No Idea
- Do you feel there need institute of higher education in the field of Textile and /or Fashion Technology.  
Choose an item.
  - If YES Please give your reasons. Click here to enter text.
- Do you feel building a University of textile would be beneficial to industry / society by provided better quality education due to larger resources at hand?  
Choose an item.
- Do you feel Textile University would give more opportunities for new researches and innovation potentially useful for the Industry and Society?  
Choose an item.
- Do you feel Textile University would open fresh avenues for research /Consultancy and sponsored projects to inculcate a scientific temper and outlook? Choose an item.
- Do you feel Textile University would create more job and career opportunities in many areas and in varied profiles?  
Choose an item.
- Do you feel textile and allied industry have demand and will use student with PG degree in the subject. Choose an item.
- Do you feel Textile University would attract foreign students from neighboring countries not having ample educational institutional infrastructure?  
Choose an item.
- Please pick ONE or MORE field of studies you wish to be incorporated in higher textile education.

Fashion <input type="checkbox"/>	Entrepreneurship <input type="checkbox"/>	Information Technology <input type="checkbox"/>
Accounting & Finance <input type="checkbox"/>	Performance Management <input type="checkbox"/>	Project Management <input type="checkbox"/>
- Do you feel upgrading IICT to university level would be advantageous and should be preferred
  - Yes
  - NoPlease give reasons Click here to enter text.
  - Can't Say
- Do you feel upgrading IICT to university at Bhadohi would have locational advantage or locational disadvantage.  
Choose an item.
  - Please give reason for your choice. Click here to enter text.

#### Please tell us about yourself

Your Age: Click here to enter text. Gender: Choose an item. Occupation / Profession: Choose an item.  
Your Work / Professional Experience: Click here to enter text.  
Industry /Company / University Name: Click here to enter text.  
Your Work City : State : Country:

# QUESTIONNAIRE FORMAT (PHYSICAL)

## Questionnaire Format (Physical)

**Questionnaire for Feasibility study on up-gradation of IICT, Bhadohi  
To a National Level Textile Institute of the University Level**

1. Are you aware of any textile University in India or abroad? YES  NO

2. Are you aware about IICT (Indian Institute of Carpet Technology, Bhadohi) YES  NO

3. If YES, have you got a chance to interact / associate with IICT, Bhadohi. YES  NO

4. If YES, in what capacity have you interacted with IICT (You may choose more than one option)

a. Current /Ex Student	<input type="checkbox"/>	b. Current /Ex Employee	<input type="checkbox"/>	c. Guest /Invitee	<input type="checkbox"/>
d. Industry Client of IICT (Consultancy or other services)	<input type="checkbox"/>	e. Employer of IICT Graduates	<input type="checkbox"/>	f. Academic Institutions (Carpet/Textile/Fashion/Allied Areas)	<input type="checkbox"/>
g. Industry in the field of (Carpet/Textile/Fashion/Allied Areas)	<input type="checkbox"/>	h. Other Industries	<input type="checkbox"/>	i. Other Academic Institutions	<input type="checkbox"/>
j. Trade Bodies / Organizations	<input type="checkbox"/>	k. Current /Ex-Supplier/Contractor (Services)	<input type="checkbox"/>	l. Current /Ex-Supplier/Contractor (Equipments)	<input type="checkbox"/>

5. How do you perceive IICT's contribution towards the Industry and society at large.

a. Excellent, Has Contributed Significantly towards development of Industry and Human resources	<input type="checkbox"/>
b. Very Good, has contributed to a very good extent	<input type="checkbox"/>
c. Good, has contributed to some extent	<input type="checkbox"/>
d. Poor, No contribution at all	<input type="checkbox"/>
e. No Idea	<input type="checkbox"/>

6. Do you feel there is need of an Institute of higher education in the field of Textile and/or Fashion Technology? YES  NO  May Be  Can't Say

If YES kindly give reason(s) \_\_\_\_\_

7. Do you feel building a university of textile would be beneficial to Industry / Society by providing better quality education due to larger resources at hand? YES  NO  May Be  Can't Say

8. Do you feel textile university would give more opportunities for new researches and innovation potentially useful for the industry and society? Definitely Yes  Somewhat Yes  Definitely No  Somewhat No

9. Do you feel textile university would open fresh avenues for research / consultancy and sponsored projects to inculcate a scientific temper and outlook? YES  NO

10. Do you feel textile university would create more job and career opportunities in many areas and in varied profiles? Definitely Yes  Somewhat Yes  Definitely No  Not Sure

11. Do you feel textile and allied industry have demand and will use students with PG degree in the subject? YES  NO

12. Do you feel textile university would attract foreign students from neighboring countries not having ample educational institutional infrastructure? Definitely Yes  Somewhat Yes  Definitely No  Not Sure

13. Please pick ONE or More fields of studies you wish to be incorporated in higher textile education?

Fashion	<input type="checkbox"/>	Entrepreneurship	<input type="checkbox"/>	Information Technology	<input type="checkbox"/>
Accounting & Finance	<input type="checkbox"/>	Performance Management	<input type="checkbox"/>	Project Management	<input type="checkbox"/>

14. Do you feel upgrading IICT to university level would be advantageous and should be preferred? YES  NO  Can't Say

Kindly give reason(s) for your choice \_\_\_\_\_

15. Do you feel upgrading IICT to university at Bhadohi would have locational advantage or locational disadvantage? Locational Advantage  Locational Disadvantage  Location Immaterial

Please give reason for your choice \_\_\_\_\_

Please tell us about yourself: \_\_\_\_\_

Age: \_\_\_\_\_ Gender: \_\_\_\_\_ Occupation / Profession : \_\_\_\_\_

Your work/ professional experience (Years) : \_\_\_\_\_ Industry / Company / University Name : \_\_\_\_\_

Your work city: \_\_\_\_\_ State: \_\_\_\_\_ Country: \_\_\_\_\_

# RESPONSE SUMMARY

## Response Summary

1. Are you aware of any textile University in India or abroad?

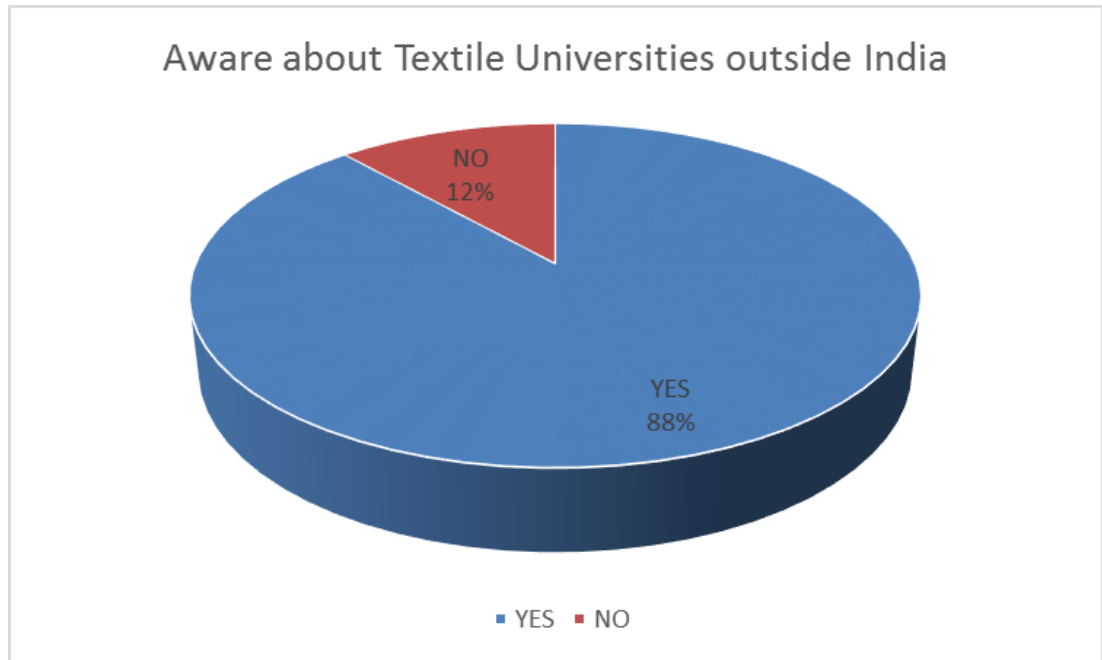

It was heartening to note that the majority of the respondents (88%) were aware about international institutions / universities in the field of textiles.

# RESPONSE SUMMARY

2. Are you aware about IICT (Indian Institute of Carpet Technology, Bhadohi)?



As most of the respondents were directly or indirectly connected with IICT, a significantly large percentage of the respondents were well aware about IICT, Bhadohi, as shown in response summary pie chart of Question No. 4.

# RESPONSE SUMMARY

3. If yes have you got a chance to interact / associate with IICT.

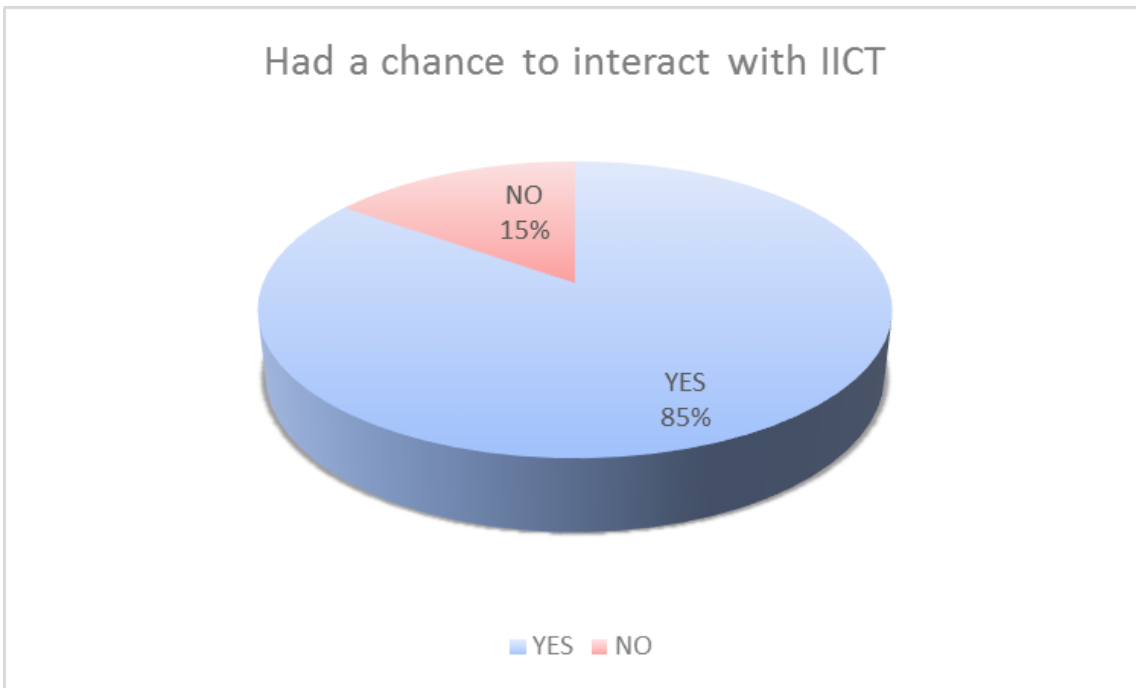

85% of respondents interacted with IICT, Bhadohi, in various capacities, some, as current students/alumni, current /ex-employees and also various professional associates / affiliates mentioned in the following response.

# RESPONSE SUMMARY

## 4. If Yes in what capacity have you interacted with IICT (You can choose more than one option)

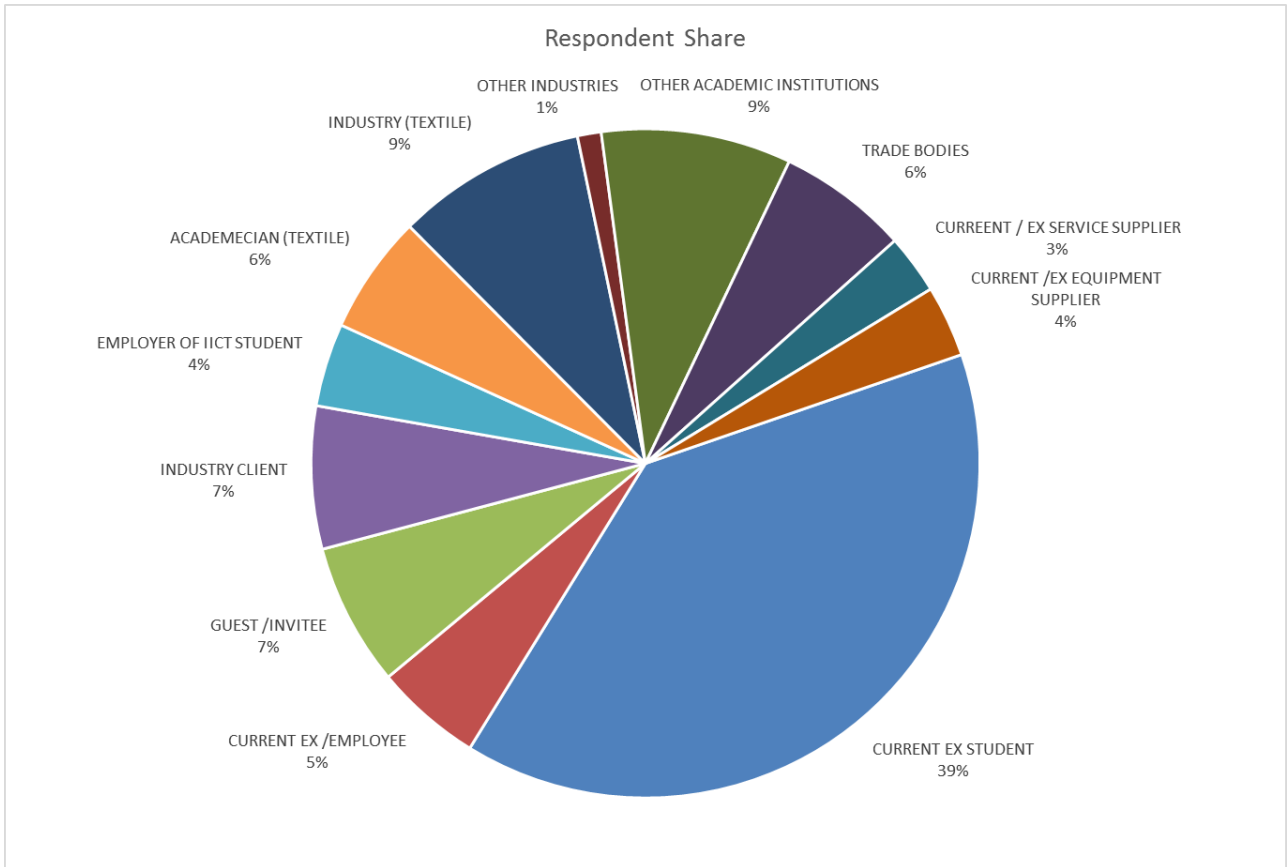

39% respondent belonged to current students and alumni of IICT. As alumni of IICT are placed in various organizations both nationally and internationally they had knowledge about IICT and were also abreast with industry requirement and needs. Rest 61% respondents belonged to other 11 categories.



# RESPONSE SUMMARY

5. How do you perceive IICT's contribution towards the industry and society at large?

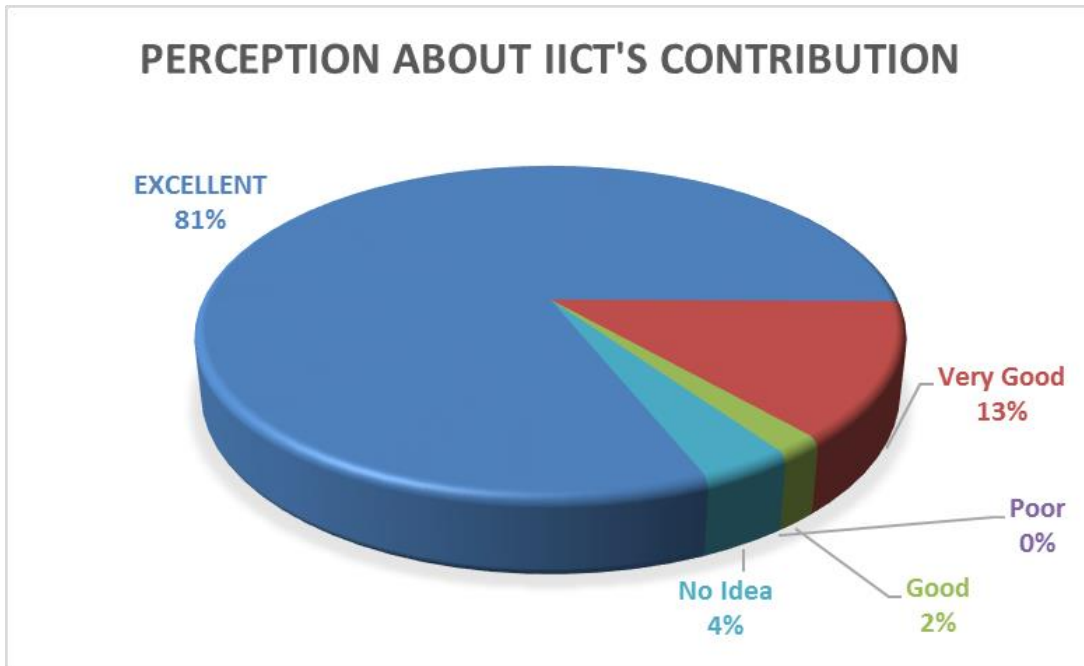

A significant majority of respondents were happy with IICT as 2% rated it as Good, 13% as very good and 81% excellent. 4% of respondent did not have an idea about IICT's contribution; the significant observation was that none of the respondents had negative or poor impression about IICT. The contribution of IICT was as per their own perception as there were no leading suggestions.

# RESPONSE SUMMARY

6. Do you feel there is a need for an institute of higher education in the field of Textile and /or Fashion Technology?

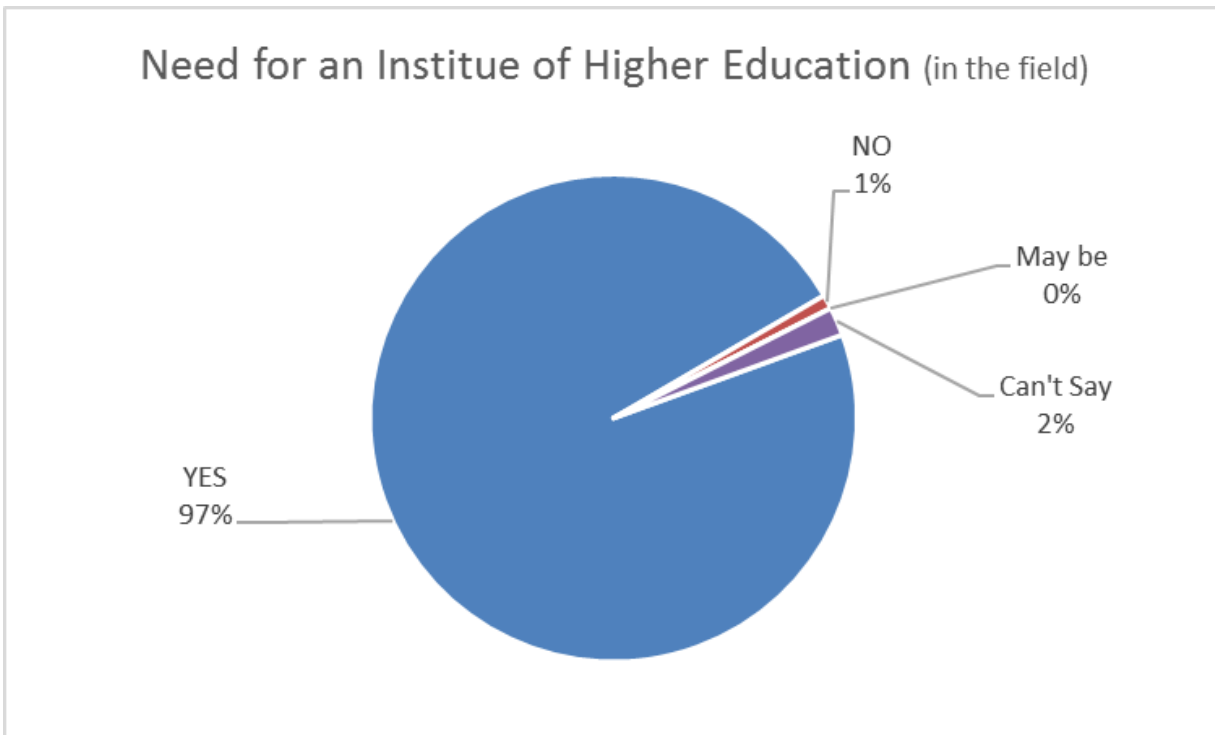

Majority of respondents felt the need for an institute of Higher Education in the field of textile and fashion. The possible reason for such a massive response could be that generally people yearn for degrees rather than certificates and diplomas.

SOME OF THE REASONS PUT FORTH BY RESPONDENTS TO SUPPORT THEIR CLAIM FOR ESTABLISHING AN INSTITUTE OF HIGHER EDUCATION IN THE FIELD OF TEXTILE AND CARPET.

**Fashion Industry is growing very fast and such institutes would sure help the students in getting better opportunities**

**It will prepare students for a career in textiles and research laboratory**

# RESPONSE SUMMARY

Present era is being looking for specialized career in carpet industries, besides this we need to have MBA program in the same so that students can understand the carpet business which is unlike other products in the textiles or FMCG or consumer goods

---

**In this way, one may get core knowledge of his preferred area of specialization and mastering over that**

---

**There is a need of a top class institute in the field of textile research which would give pace for innovation in textiles as they are rather stagnant now a day**

---

**Research and Development is key to survive in textile industry**

---

**In this way, one may get core knowledge of his preferred area of specialization and mastering over that**

---

**To upgrade carpet and textile technology**

---

**Teachers as well as students will have more expertise over these subjects and its related areas. As a result, faculties and students are able to innovate new ideas and produce good research, which our country needs now.**

---

**For doing better**

---

**There is no other institute in textile and fashion other than NIFT and IIT which has come up with a brand image globally**

---

**Despite India being big market for textile there is no university providing diversification opportunities towards defense clothing and other areas**

---

**There is no scope of B. Tech students studying here to upgrade to M. Tech programs hence needed**

# RESPONSE SUMMARY

**It will help the skill development**

---

**To meet the existing demand of student's form IICT and elsewhere**

---

**There is an urgent need of an institution of higher education in the field of textile and fashion**

---

**Industry needs such institution in the area**

---

**For industry help and support**

---

**Because world is globalizing day by day but in Bhadohi there is not nay engineering college /university so we need here university**

---

**We will get advantage of study in the field of textile and fashion technology**

---

**Because India doesn't have any such university**

---

**As for a world level institute, it needs higher education so that institute can contribute significantly to the industry as well a country**

---

**There is need for a institute of higher education in textiles**

---

**Yes I feel because we can find new possibilities after higher education**

---

**Because we can find new possibilities after higher education**

---

**It would benefit student and the industry**

---

**Because in today's generation it is very necessary for all of us to receive higher studies**

---

# RESPONSE SUMMARY

7. Do you feel building a University of textile would be beneficial to industry / society by providing better quality education due to larger resources at hand?

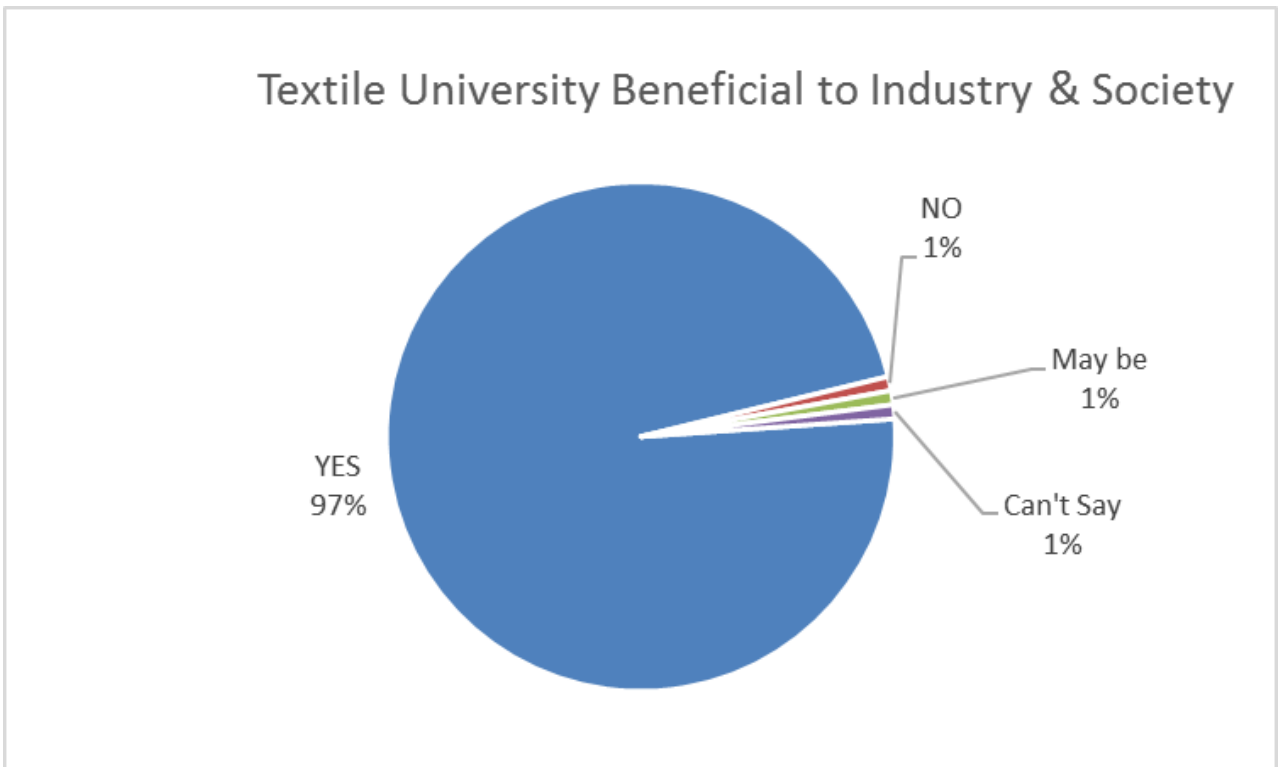

There is a strange coincidence of 97% respondents answering positively towards the assertion. Though 1% of respondents were against and another 2% were rather indifferent with “May be” and “Can’t say” responses.

# RESPONSE SUMMARY

8. Do you feel Textile University would give more opportunities for new researches and innovation potentially useful for the Industry and Society?

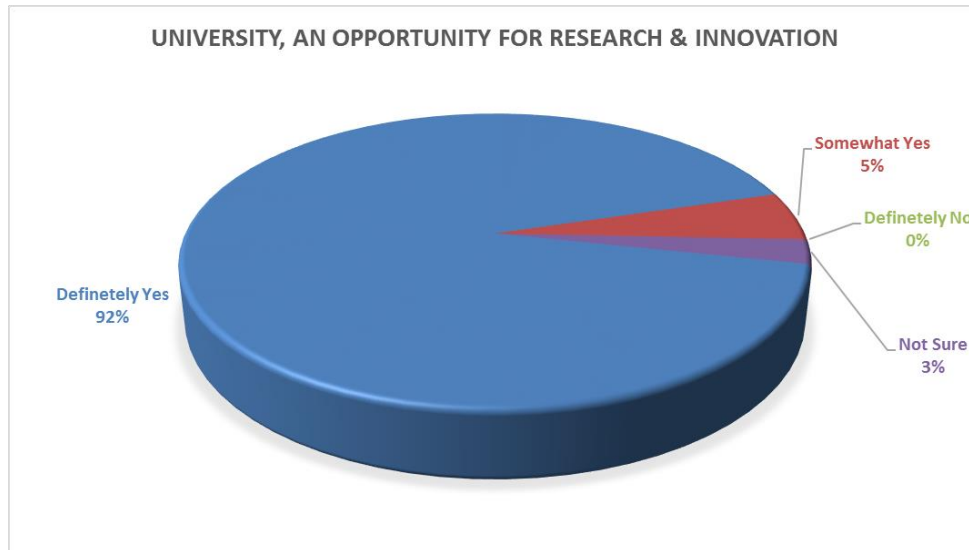

Though 3% were not sure about university's possibility of being an opportunity for Research and innovation, and another 5% were somewhat positive, but majorities 92% were very sure as they responded "definitely yes", when asked about the possibility of such university promoting research and innovation. It is usually expected that University level institution would offer such opportunities.

# RESPONSE SUMMARY

9. Do you feel Textile University would open fresh avenues for research /Consultancy and sponsored projects to inculcate a scientific temper and outlook?

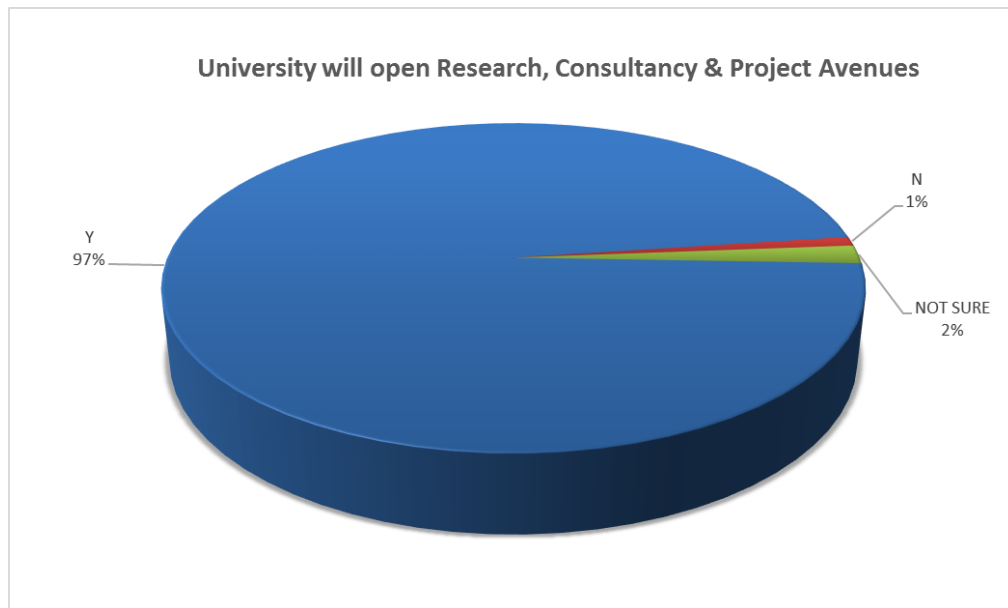

97% respondents were also positive about the possibility of such university opening new avenues for research, consultancy, though a small percentage were not too sure about it. Seems that scope of carpet may be limited as such getting into the bigger domain of textiles would give greater scope and be more beneficial.

# RESPONSE SUMMARY

10. Do you feel Textile University would create more job and career opportunities in many areas and in varied profiles?

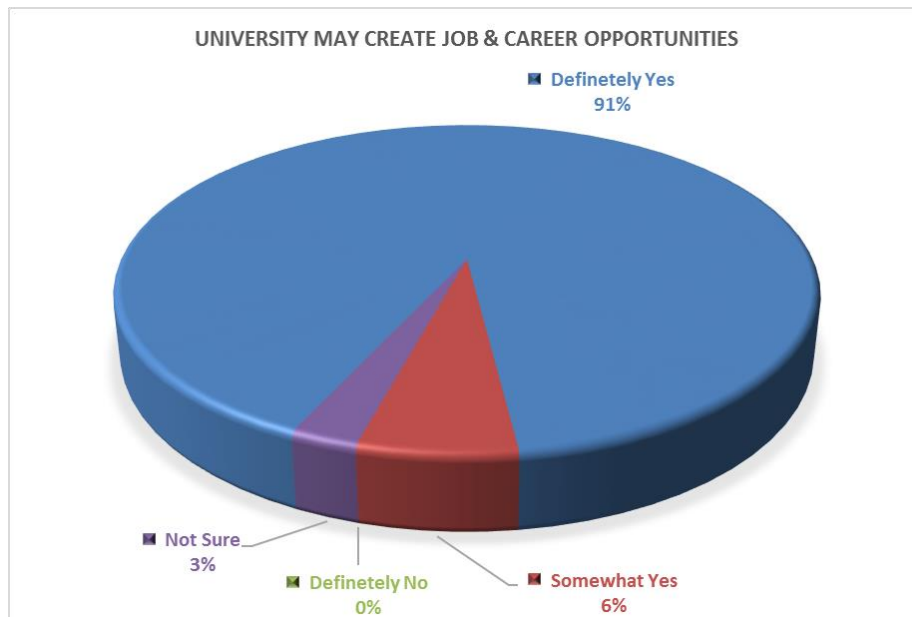

Once again a majority of respondents (91%) felt that such university would also give new opportunities of career and job to the students, whereas 6% were affirmative but not so positive and another 3% were not sure. However, no one preferred otherwise.



# RESPONSE SUMMARY

11. Do you feel textile and allied industry have demand and will use student with PG degree in the subject?

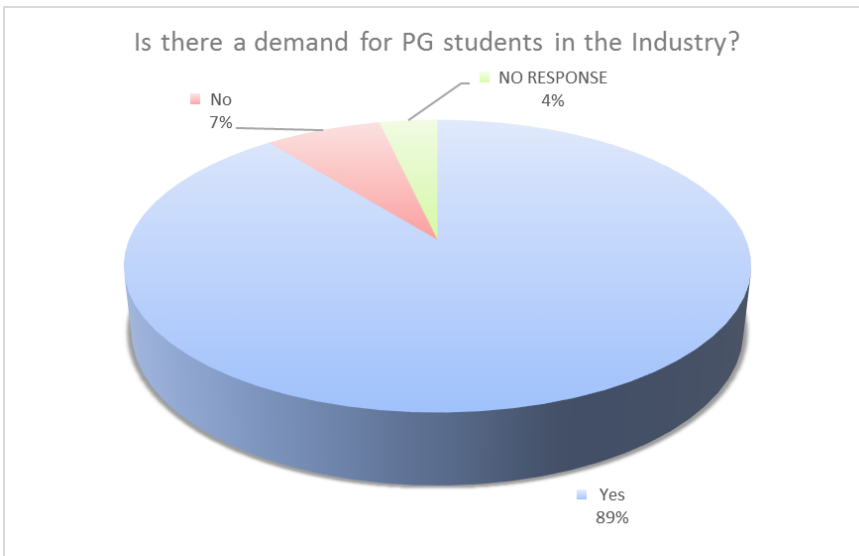

89% respondents were positive about the assertion hoping that a bachelor degree is better than a certificate and a diploma, and in continuation a post graduate degree is still better as compared to a bachelor degree. 7% respondents believed that there is no need for PG students in the textile industry, and another 4% chose not to respond.

# RESPONSE SUMMARY

12. Do you feel Textile University would attract foreign students from neighboring countries not having ample educational institutional infrastructure?

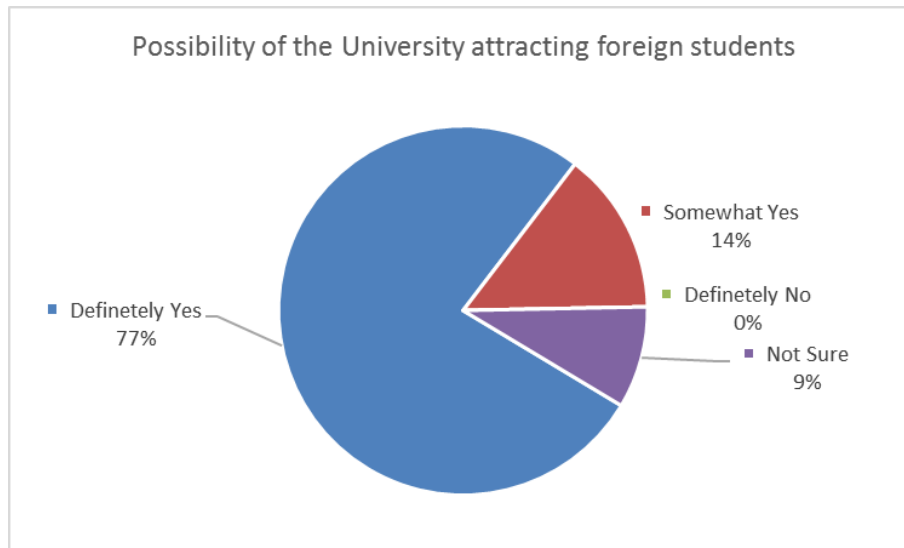

With the change circumstances of India shining, it is believed as being corroborated by the responses of 77% hoping for such an action to take place.

# RESPONSE SUMMARY

13. Please pick ONE or MORE field of studies you wish to be incorporated in higher textile education.

Table sorted in order of preference (From most to least)

Discipline	Respondent Preference
Fashion	21%
Entrepreneurship	19%
IT	17%
Project Management	16%
Acntg & Finance	14%
Performance Management	13%

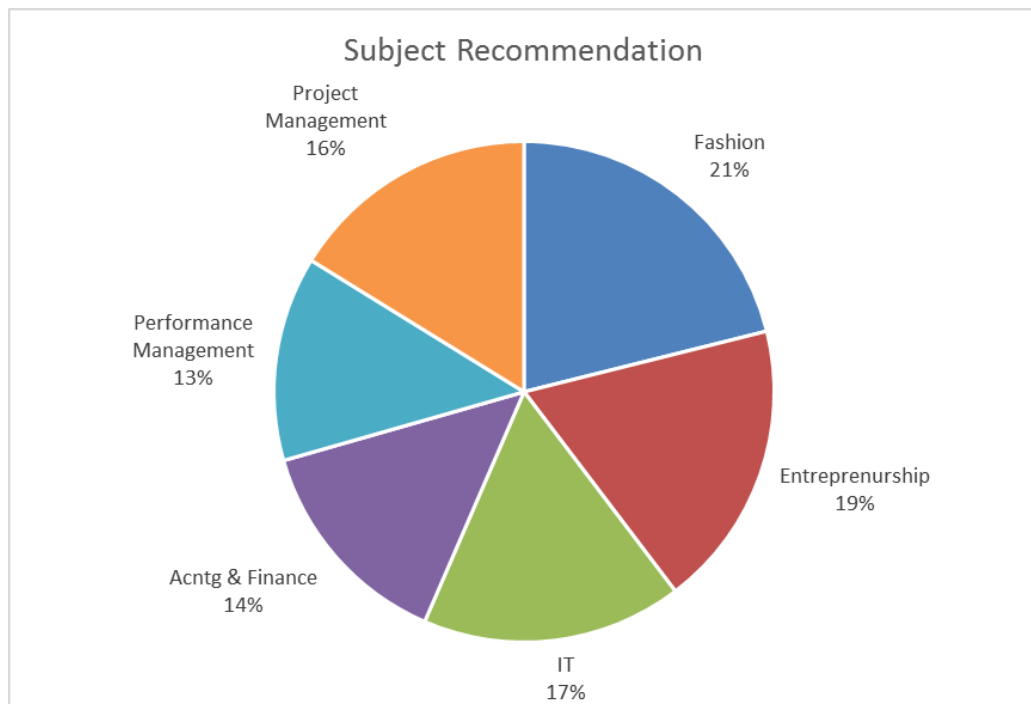

When asked about new subjects / streams to be incorporated, Fashion (21%) was the majority choice closely followed by Entrepreneurship (19%), then Information technology 17%, Project management (16%), Performance Management (16%) and lastly accounting and Finance (14%). The difference between the choices is not very large; it appears that people have similar interests in the choices given.

# RESPONSE SUMMARY

14. Do you feel upgrading IICT to university level would be advantageous and should be preferred?

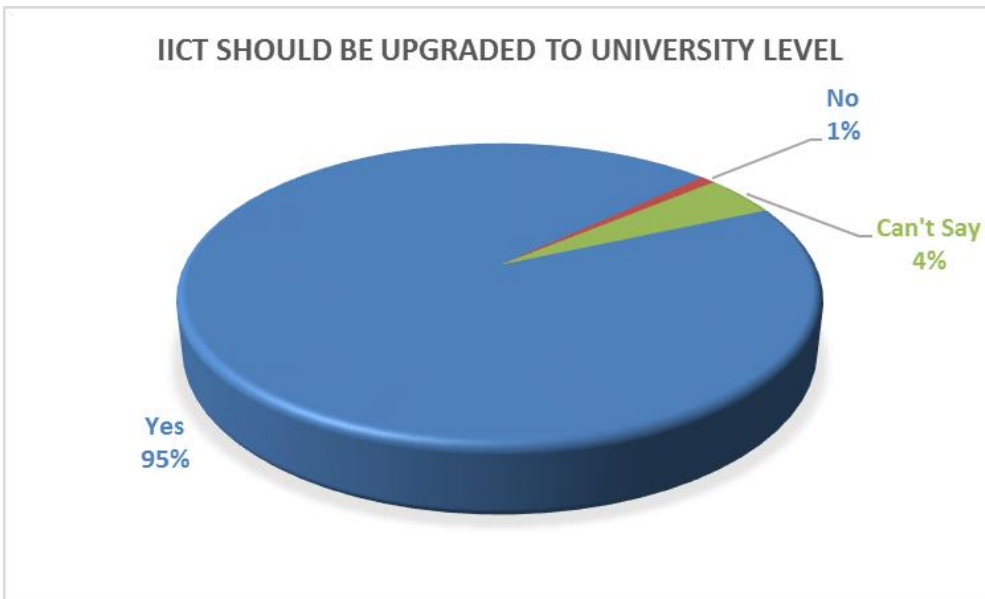

IICT, supported by 95% of respondents, was a popular choice for upgradation to an university level in the field of textile. A very small section (1%) thought against it, and another 4% were not sure about this choice.

SOME OF THE REASONS PUT FORTH BY RESPONDENTS TO SUPPORT THEIR CHOICE FOR UPGRADING IICT TO UNIVERSITY LEVEL (BOTH FOR AND AGAINST)

**IICT has the experience of operating with the industry its upgradation would be better as it would save time.**

---

**I will support upgrading the institute to a national level but not to university level**

# RESPONSE SUMMARY

**It may provide opportunities for advance learning and research leading up to a PhD in branches as would be incorporated in higher textile education. Moreover, the right of granting degrees would be given to the University**

---

**IICT already has great infrastructure and potential**

---

**It may provide opportunities for advance learning and research leading upto a PhD in branches as would be incorporated in higher textile education. Moreover, the right of granting degrees would be given to the University**

---

**IIC has got enough infrastructure in the field of textile and carpets and this would help in further upgradation of the institute to become a university**

---

**In home textile IICT is the only institute in India where complete home furnishing facilities is there**

---

**IICT is an established platform hence effort would be less to establish the university**

---

**It would be beneficial for the existing students and this will develop and upgrade the location**

---

**There is need for professionals in the field of carpet designers who are able to use the tools, Upgrading IICT would be the right thing to do to optimize the efforts and expenses.**

---

**IICT is already there in the market, and there are not many professionals except those who are being produced from IICT**

---

**It will be preferred because we can develop our ideas with the help of higher education**

---

**Because IICT is a perfect place and has a lot of potential.**

---

**It would get world recognition**

---

**It would give worldwide recognition**

# RESPONSE SUMMARY

15. Do you feel upgrading IICT to university at Bhadohi would have locational advantage or locational disadvantage?

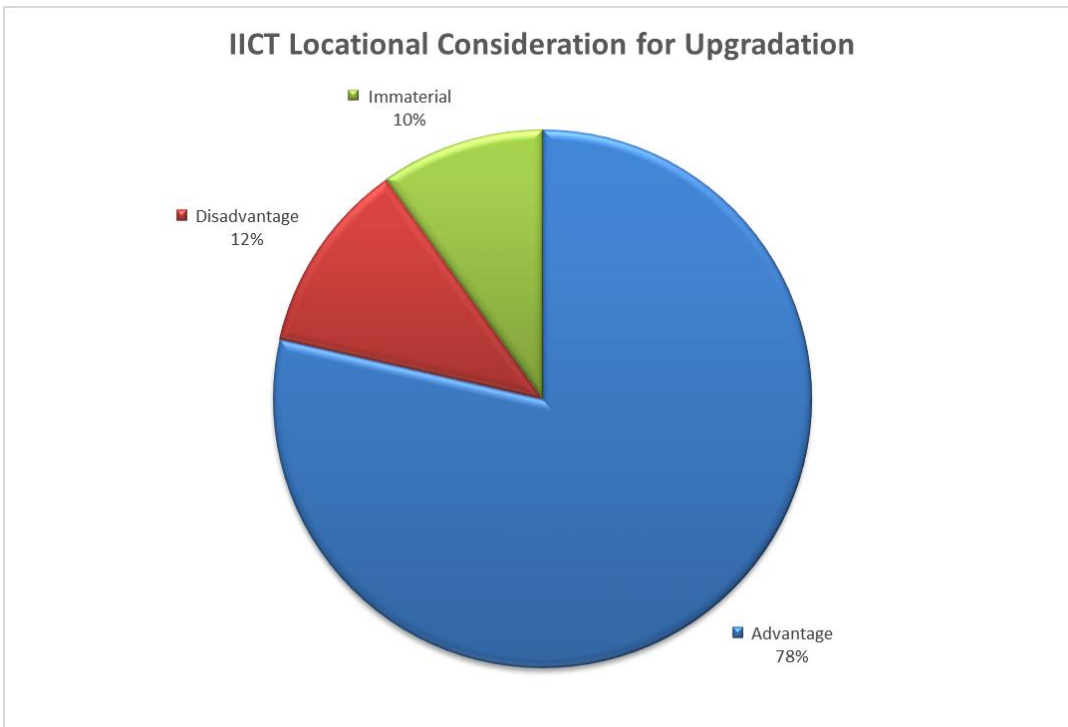

78% of respondents thought that Bhadohi has locational advantage if IICT is upgraded to an institute of higher education or to a university whereas 12% disagreed with the idea, and another 11% thought location is really immaterial for such an institution and the students would come any way.

SOME OF THE REASONS PUT FORTH BY RESPONDENTS TO SUPPORT THEIR OPINION ABOUT LOCATIONAL ADVANTAGE OR DISADVANTAGE OF UPGRADED INSTITUTE BEING IN BHADOHI

**Being in the vicinity of the carpet industry belt, would give better opportunities of exposure to the students**

---

**Bhadohi being a remote place**

---

**The geographical location of the institute from many angles is certainly not a suitable place for location of a university.**

# RESPONSE SUMMARY

Being carpet village students can learn much and can have machinery experience a lot in carpet field plus designing they need to work hard in the field of designing, should know textile well before they choose for designing job. As all the facilities are locally available in Bhadohi, so I feel they have working experience in the same locality and apply their innovation without going to long distance

---

The location is not suitable for textile university because it will give less opportunity to students

---

Many students don't prefer IICT because of its location, so I don't think it has an advantage. If it would have been a proper city or even in Varanasi, people would prefer going there.

---

The prime objective of serving the industry and grooming manpower according to the need of the industry would be better understood locally.

---

Nearby located textile industries are added advantage

---

The prime objective of serving the industry and grooming manpower according to the need of the industry would be better understood locally.

---

Bhadohi is carpet belt of India

---

Locals will get access to higher education, would also get job opportunities

---

Industrial Background, Railway Connectivity

---

This institute is within the Industry belt, Bhadohi carpet and Varanasi Fabric

---

The area is developing very fast and connectivity of Bhadohi has improved, BIDA has tane many steps, and Bhadohi is coming up as a major center hence it would be advantageous

# RESPONSE SUMMARY

**Already developed industry**

---

**Because this is already developed and established cluster**

---

**Carpet industry is worth 8000 Cr, which is located in and around Bhadohi whereas Saree Industry is only worth about 800-1000 cr, hence it makes sense to establish the university in Bhadohi**

---

**Students would get the opportunity to study in their hometown**

---

**Because it just next to Varanasi and Allahabad and also a carpet place so it is very good for it. And also students of such cities will get opportunities**

---

**IICT is a very good place to develop infrastructure for a textile university**

---

**It is located in India's carpet city Bhadohi**

---

**Because this area is related to carpet**

---

**Bhadohi is a well know place for carpet**

---

**It is located carpet city Bhadohi**

---

**More companies would be installed so a greater export will be there**

---



# SWOT STATEMENTS (IICT FACULTY , STAFF & STUDENTS)

## SWOT STATEMENTS (IICT FACULTY , STAFF & students)

### FACULTY

STRENGTHS AS RECORDED THROUGH FEEDBACK (*The following statements are exact statements given by the respondents, hence at some places there might be grammatical errors*)

#### S1

1. Qualified staff and faculties
2. Transparent implementation of policies
3. Renowned for its unique existence and works done in its domain
4. Being a centrally funded institute necessary expansions may be planned and implemented.
5. No local pressure on internal administrative policies.
6. Very good cooperative environment of learning and growing as an individual employee as well as student.
7. Timely disbursement of compensation
8. Strong and Clear vision of future targets.

#### S2

1. Good Infrastructure
2. NABL lab facilitating display of sample and convenient access to students.
3. Laborious and active student

#### S3

1. Unique and first institute of its kind.
2. Student occupancy is 100%
3. 100% placement
4. Fully equipped center, for industry, exporters, manufacturers and customers.

#### S4.

1. Cooperative and accessible management.
2. Good Infrastructure and equipment
3. Qualified and competent staff
4. Consultancy provided to industry
5. Availability of research facility in hand made carpets

#### S5.

1. Well-equipped lab for students and for industry support.
2. Qualified and competent faculty and staff
3. 100% placement
4. Ample machines (equipment) for students and to provide technical support to industry.
5. Good number of external projects in the areas design, computer and dyeing.

#### S6.

1. Exclusive program helpful for students, industry and people at large.
2. Good Infrastructure
3. Financial support by MOT.

# SWOT STATEMENTS (IICT FACULTY , STAFF & STUDENTS)

4. Good quality student intake generally through IITJEE (Mains)

S7.

1. Qualified staff and faculty
2. Transparent implementation of policies
3. Design department and projects
4. Honest, sincere staff and faculties
5. Well-equipped departments.
6. Director

S8.

1. Institute specialized in carpet and textile.
2. The carpet export turnover in India is Rs. 5000 crores.
3. Major export is done from Bhadohi.
4. This course specialization is more reliable for industry.
5. Well qualified and industrial experience faculty.
6. Our four portfolio activities are more relevant to the industry.

S9.

1. Full Support of Central Government.
2. Very limited number of textile colleges in India.
3. Well qualified staff and faculty.
4. ISO 2009 certified institute
5. NABL accredited lab.
6. Star Performer College in Uttar Pradesh.
7. 100% placement record.
8. Well-equipped lab and workshop.
9. Good industry interaction.

S10.

1. All faculty and staffs are well qualified.
2. All are honest and devoted to their work.
3. Institute and Laboratory is accredited and certified by NABL AND iso 2009.
4. Workshops are well equipped.
5. Laboratory is also well equipped by latest version of equipment.
6. Our institution students have qualified GATE examination with good score.

S11.

1. The institute is one of its kinds in the world.
2. It is located in the carpet hub of the country.
3. Having all most all types of machines related to this field.
4. As on date all seats have been fulfilled up in B.Tech course.
5. Placements of all students have been done for every batch.
6. Almost all facilities required for carpet manufacturing manufacturers, exporters and buyers also.

# SWOT STATEMENTS (IICT FACULTY , STAFF & STUDENTS)

7. Have sufficient number of experienced faculty.

S12.

1. Having well experienced and qualified faculties and staffs.
2. Having sufficient number of academic buildings for running the classes.
3. Having peaceful and pollution free environment for staying in campus.
4. Having sufficient equipment to pursue research.
5. Having 24 hours' electricity.
6. Having a good library with lots of collection of books.
7. Communication facilities are nice.

S13.

1. Ample space for future development.
2. Only institute of its kind offering professional degree in carpet technology.
3. Located in carpet belt has good industry interaction and support for carpet courses.

S14.

1. One of the unique institutes in Asia for Carpet and Textile.
2. Accreditation of B. Tech with the Textile Manchester.
3. Accreditation of IICT lab by NABL.
4. Highly qualified teaching staff of IITians.
5. Green healthy environment atmosphere and campus.
6. Well-equipped labs, infrastructure, library and facilities.

S15.

1. Very good institute on carpet textile and technology.
2. Very good facilities on carpet technology, improvement required in textile field.

S16.

1. Institute is in middle of the industry with proper technical know-how supply to industry, institute can really contribute to the growth of industry.
2. Existing facilities are good enough for providing industry support.

S17.

1. Best laboratory related to carpet.
2. Well experienced teacher in the area of carpet manufacturing.
3. Both technical and traditional design bank.
4. Place of institute is advantageous in terms of practical and research.
5. Bhadohi is the carpet city.

S18.

1. Very good infrastructure.
2. Upgradation is always welcome in the infrastructure state of the art and machinery.
3. Most modern equipment and workshop.

# SWOT STATEMENTS (IICT FACULTY , STAFF & STUDENTS)

## WEAKNESS, OPPORTUNITY AND THREATS

### WEAKNESS:

#### WF 1:

1. Only one stream B. Tech in Textile and Carpet Technology.
2. Exhibition and International is not done in U.S.A, Germany for faculty exposure as well as for students.
3. Campus, girls and boys hostel should be developed.

#### WF 2:

1. The land area of the institute.
2. IICT is not implementing the Career Advancement Scheme (CAS), although the proposal has been submitted to O/O DCCHC.

#### WF 3:

1. Only one branch is in IICT.

#### WF 4:

1. Academic activities are not stream lined opportunity as it should be nominally.

#### WF 5:

1. The place Bhadohi is a rural area.
2. Management system needs improvements.

#### WF 6:

1. Students come for admission in our Institution by scoring very low.
2. Most of the equipment of our laboratories is out of order due to lack of service provider.

#### WF 7:

1. Location issue
2. No promotional schemes of trust in Print, Television, Radio, Media etc.

#### WF 8:

1. Could not promote in the market like other institution.
2. Only one stream is available.
3. Nomenclature of the institute confuses the textile industry to absorb the student.
4. Foreign exposure to the students not available.
5. Foreign exposure to the faculty is also not available.
6. Participation in exhibition etc. is not done in abroad for exposure of the faculty as well as the student.

#### WF 9:

1. Inside campus area road is not sufficiently good.
2. Administrative control is not looking good.

#### WF 10:

1. Remote place without enough facility for guest faculty.
2. Lack of communication facility such as internet.
3. No facilities for machine repairs particularly the electronic appliances.
4. No facilities for the NRI students.

#### WF 11:

1. Transport facilities to reach IICT from Varanasi and railway station of Bhadohi.

# SWOT STATEMENTS (IICT FACULTY , STAFF & STUDENTS)

2. Spending lots of money on diesel expenses, no other alternate.
3. Not having play grounds for the students for extracurricular activities.
4. WiFi facility not available in the entire campus.
5. Marketing of the Institute in the World is not up to the mark.
6. Established in the polluted area.

## WF 12:

1. Employees training programs may be introduced for latest technologies.
2. Power facility for running of several machines and computers depends mostly on electricity.
3. Lack of minimum basic networking infrastructure and computer server.
4. Water supply lines needs to be repaired for the lawns.

## WF 13:

1. The instruments in the testing lab are out of order, needs to be replaced.
2. The instruments are old-fashioned.
3. During the practical, faculty members are not present, only assistants are there so the query of the students are not being handled.
4. Discipline.
5. Lack of man-power.
6. No Wi-Fi in the campus.

## WF 14:

1. No PG Diploma courses.
2. No PG courses.
3. No Ph.D. awarded.
4. The commutation by road, train and air is very difficult.
5. Position of the institute is not suitable for attracting students from all over India.
6. No permanent overhead projector in classroom, teachers have to use blackboard.
7. Very high number of projects come every year regarding seminar and workshop.
8. Research and development projects are very few in number.

## WF 15:

1. Lacking image building.
2. Students are not being offered good placements.
3. Being a carpet institute, textile industries are not interested to place IICT students.
4. Carpet is basically art and craft oriented.
5. Very difficult to get meritorious students for admission.

## WF 16:

1. Bhadohi is a rural area.
2. Air quality is not good.
3. Best hospital and school are not provided nearby Bhadohi.

## WF 17:

1. At present filling of 60 students is difficult, 20 students at All India level.
2. 40 students from local
3. In the case of University following facilities like infrastructure, computer lab, Wi-Fi, playground, gym and canteen has to be in place.
4. Female employees should not be recruited as there is no promotion, no child care leave.

## OPPORTUNITIES.

# SWOT STATEMENTS (IICT FACULTY , STAFF & STUDENTS)

## OF 1:

1. M.Tech should be approved.
2. MBA and Diploma courses may be approved.

## OF 2:

1. Courses like PG Diploma, short term Diploma in textiles and Management can be opened with the present infrastructure.
2. There are needs from the industry for the above courses.
3. Since textile in general is a mother industry of India, the courses are likely to be self-sustained.
4. If converted to University the status-quo of the employees will improve certainly

## OF 3:

1. Multi-disciplinary courses may be introduced at the level of UG, PG and Research.
2. Projects may be obtained from Department of Science and Technology and MHRD.
3. More industry participation, interactive classes may be introduced for attractive industry.

## OF 4:

1. Freedom to start course of one-choice.

## OF 5:

1. Expanding dimensions and creating University would all together change the status of institute among the other colleges.

## OF 6:

1. Can be upgraded up to the University level.
2. More courses may be introduced.
3. Need to upgrade ourselves.

## OF 7:

1. Can produce young and skilled engineers for the World.
2. Develop ourselves in terms of research.
3. New ideas and results must benefit the carpet industry.

## OF 8:

1. IICT may be converted into School of Textiles with one discipline in Carpet Technology.

## OF 9:

1. Rather than converting into a University, institute level facilities should be at place for the students.

## THREATS

### TF 1:

1. The location of IICT is in a very good atmosphere for industry support.

### TF 2:

1. Location is at a remote place between Varanasi and Allahabad.
2. Internal issues of employee welfare in terms of welfare etc. not yet settled.

### TF 3:

1. May not attract students for carpet related courses.
2. Autonomy to conduct exam and provide degree within time frame.

### TF 4:

1. Due to market shortage product may is not exported.
2. Generally carpets are used in the cold countries so it should be exported to outside otherwise it would pose a threat.

### TF 5;

# SWOT STATEMENTS (IICT FACULTY , STAFF & STUDENTS)

1. Placement of pass out students would be a problem.
2. Placements depends on market, demand of carpet or floor covering in the World.
3. Funds for meeting escalating expenditure.
4. Lacking Faculty Development Programs.

## TF 6:

1. No exposure for faculty.
2. Travelling allowance for attending conference not provided.
3. Higher education facility is not provided.
4. No study leave.

## SUGGESTIONS/ RECOMMENDATIONS:

### SF 1:

1. First institute of National level. Then University.

### SF 2:

1. To upgrade IICT into National Level Institute of Carpet and Textile Industry.

### SF 3:

1. Not in a position to convert the Institute to University right now.

### SF 4:

1. Internal issues need to be settled as early as possible and to go for up gradation to the level of University then.

## STAFF

### STRENGTH:

#### SS 1:

1. Being in a city known as the Carpet city, Bhadohi the institute has locational advantage and may be extended to higher level with more carpet and Textile related branches.
2. Carpet Industry related issues are being solved and more attention may be paid in industry services which requires the expansion activities of the Institute.
3. Additional land availability is 15 acres close to IICT premises is a positive resource available.
4. Resources available may further be explored.

#### SS 2:

1. Sufficient manpower in existing trade B. Tech in Carpet and Textile Technology.
2. Infrastructure is sufficient.
3. Sufficient man-power and resources.

#### SS 3:

1. The institute has better infrastructure.
2. Well equipped with world class machines and equipment.
3. B. Tech students and trainees are very useful for carpet and allied industry.
4. Institute is very helpful for carpet and allied industry in giving consultancy and sorting their problems in the product development.

#### SS 4:

1. Majority of the carpet work takes place in Bhadohi.
2. There is a need of carpet industry but IICT is sufficient.

# SWOT STATEMENTS (IICT FACULTY , STAFF & STUDENTS)

SS 5:

## WEAKNESS

WS 1:

1. Out of 57 sanctioned posts, only 29 posts are filled as the retention of staff is a problem.
2. The recruited staff of IICT use the institute as a platform and leave after four to five years for better prospects.
3. Better atmosphere must be ensured in the institute with lucrative facilities so as to retain the efficient and effective staff.

WS 2:

1. For the up grading, the institute requires land which is not enough.

WS 3:

1. Lack of space.

## OPPORTUNITY:

OS 1:

1. Institute is following 6th CPC recommendations and the compensation package.
2. Put extra effort in discharging office duties so as to explore the opportunities for betterment of ourselves and the institute.

OS 2:

1. Youngsters would be provided a chance to study in home-district.

OS 3:

1. The carpet belt would be benefitted.

OS 4:

1. Development in the carpet belt of Varanasi.

OS 5:

1. Development of entire industry and Bhadohi.
2. Development of the institute at world class level.
3. Development of staff and faculty.
4. Development of students.

OS 6:

1. Opportunity for higher education.
2. Generation of employment opportunities.

## THREATS

TS 1:

1. Infrastructure facility is not good.
2. Means of communication.



# SWOT STATEMENTS (IICT FACULTY, STAFF & SUTDENTS)

## SWOT STATEMENTS (IICT FACULTY, STAFF & SUTDENTS)

### STUDENTS

#### SWOT-STUDENTS

##### STUDENT 1:

###### \* STRENGTH:

1. Unique college in Asia.
2. Nicknamed as 'Carpet City'.

###### \* WEAKNESS:

1. Unable to shift to industries.

###### \* OPPORTUNITY:

1. Job opportunities are available abroad.

###### \* THREAT:

1. Training and Placement problems.

##### STUDENT 2:

###### \* STRENGTH:

1. All machines are present.
2. Good infrastructure.
3. 24 hours electricity.

###### \* WEAKNESS:

1. No fix schedule.
2. Various modes of admission.
3. No support from faculty for Training and Placement.
4. Lack of student friendly library.
5. Poor Personality Development.

###### \* OPPORTUNITY:

1. Provides a platform for GATE entrance.

###### \* THREAT:

1. Placement.

# SWOT STATEMENTS (IICT FACULTY, STAFF & SUTDENTS)

2. No industry interaction.

STUDENT 3:

\* STRENGTH:

1. Hardworking and dedicated faculty.

\* WEAKNESS:

1. Poor mess facility.

2. Internet facility is not available to individuals.

3. Placement.

4. Less opportunities in textile sectors.

5. Lack of facilities and guidance for Research and Development.

6. No medical facilities.

\* OPPORTUNITIES:

1. Special classes should be provided for higher studies.

2. Placement package should be assigned to a minimum level.

3. Committee should be assigned for Placements.

4. Library facilities should be extended.

\* THREATS:

1. Lack of opportunities to interact with industrialists.

2. Lack of Industrial tours.

3. Pure drinking water is not available.

STUDENT 4:

\* STRENGTH:

1. Good ranks are occupied in GATE.

2. Good atmosphere.

3. Well maintained library.

4. Bright future.

\* WEAKNESS:

1. No industrial visit.

2. Working hours of the library.

3. Lack of coordination between the faculties and students.

4. No Wi-Fi connection in girl's hostel.

5. Lack of effort for Placement in textile industries.

# SWOT STATEMENTS (IICT FACULTY, STAFF & SUTDENTS)

\* OPPORTUNITY:

1. Great opportunity to serve the Carpet and Textile Industry.
2. Platform to showcase student's talent.

STUDENT 6:

\* STRENGTH:

1. Unique college in Asia.
2. Platform for the Carpet and Textile Technocrats.
3. Providing technical knowledge to the Carpet industry.

\* WEAKNESS:

1. No development in the infrastructure.
2. Timings of the library.
3. Notices are not circulated regarding the holidays.

STUDENT 6:

\* STRENGTH:

1. Good infrastructure.
2. Provides B.Tech in Carpet and Textile technology.
3. 100 percent placement.
4. Best textile lab.

\* WEAKNESS:

1. Lack of interest of students in CTT branch.
2. Lack of coordination between the faculty and the student.
3. No medical facilities.

\* OPPORTUNITY:

1. Great opportunity for jobs.
2. Improvement of personality.

STUDENT 7:

\* STRENGTH:

1. Unique college in Asia.
2. 100 percent placement.

# SWOT STATEMENTS (IICT FACULTY, STAFF & SUTDENTS)

3. Infrastructure is excellent.
4. Practical lab is well equipped.
5. Practical lab contains new lab models of each machine.
6. College's location.
7. Linked to National Highway.

\* WEAKNESS:

1. Placement is less.

\* OPPORTUNITY:

1. Achieve good rank in GATE examination.

\* THREATS:

1. Faculty.
2. No playground.
3. No personality development.

STUDENT 8:

\* STRENGTH:

1. Single institute of Carpet Technology.
2. Better infrastructure.
3. Life is easier in IICT.

\* WEAKNESS:

1. Development rate is very slow.
2. Only few faculties are good.
3. No extracurricular activities.
4. Lack of placement.
5. Library.

\* OPPORTUNITY:

1. Flyover for admission in IITs for M.Tech.
2. Less opportunities for good package placement.

\* THREAT:

1. Major weapon of faculties is threat.
2. Threatening to students regarding degree.

# SWOT STATEMENTS (IICT FACULTY, STAFF & SUTDENTS)

STUDENT 9:

\* STRENGTH:

1. Modern equipment available.
2. Layout is good.
3. Various programs for the students.
4. Hostel infrastructure is good.
5. Internet is good.

\* WEAKNESS:

1. Fear of faculty.
2. Lack of coordination between the faculty and the student.
3. Behavior of management is furious with students.
4. Private life of student is not safe.
5. Sufficient books are not available in library.
6. Faculty is not interested in welfare of the students.
7. No medical facility is available.
8. Placement status is not impressive.
9. Mess facility is not good.

\* OPPORTUNITY:

1. Opportunities for higher education.

STUDENT 10:

\* STRENGTH:

1. Wide range of students coming.
2. Centrally funded.

\* WEAKNESS:

1. Direct admission.
2. Promotion of College.
3. Syllabus pattern.
4. Absence of Digital library.
5. No sports facilities.
6. No water-purifiers.
7. No Xerox machines in college.
8. No facility for guests.
9. Campus environment is not friendly.

# SWOT STATEMENTS (IICT FACULTY, STAFF & SUTDENTS)

## \* OPPORTUNITY:

1. Wide range of jobs.
2. Scope for Geo, Smart Technical Textiles.
3. Scope of start-ups for MAKE IN INDIA.
4. Research and Career opportunities.

## \* THREAT:

1. No proper utilization of funds.
2. No company internships.
3. Relationship between Management, Faculty and Students.

## STUDENT 11:

### \* STRENGTH:

1. Focused on Carpet and Textile.
2. Powerhouse for the Bhadohi weavers.
3. Single Carpet Institute in Asia.
4. Intake of students is 60.

### \* WEAKNESS:

1. No publicity outside Bhadohi.
2. Provides knowledge only in Carpet.
3. Placement level is very low.
4. No effective and efficient faculty.
5. Mess facility is not appropriate.
6. Wi-Fi facility is not good.

### \* OPPORTUNITY:

1. No industrial-tours.
2. Lack of opportunities for Government jobs.
3. Placement package is very low.
4. No technical and economic support.
5. No facility of transport.

### \* THREAT:

1. Faculty threatens for providing internal marks.

## STUDENT 12:

### \* STRENGTH:

1. Unique college of Carpet in Asia.

# SWOT STATEMENTS (IICT FACULTY, STAFF & SUTDENTS)

2. Varieties of machines available.

\* WEAKNESS:

1. Lack of coordination between student and administration.
2. Non-transparency in administration activity.
3. Machines don't run properly.
4. Pollution is too high.
5. No improvement in campus activity.

\* OPPORTUNITY:

1. Syllabus can be taught with electronics and new science technology.
2. Project may be far better.
3. Better products may be available due to single branch.

# SUMMARY OF RECOMMENDATIONS:

## Summary of Recommendations:

The existing status of IICT holds great potential and promise in the long run to be established as a center of excellence for the conduct of teaching, research, consultancy, design and sponsored projects in the specific areas related to and relevant to the carpet industry specifically, and in the larger canvas cater to the needs of the textile industry at large so as to enable to do this inclusively to meet the needs and aspirations of a large population specially in a country like ours.

In a phased manner what is being recommended is the upgradation of the present IICT to a better well equipped institute with strong faculty resource, capacity building; which is evolutionary, more time consuming as compared to creating infrastructure capabilities of buildings, equipment etc. In the long run what seems to be more appropriate and feasible that in a period of five years, it would seem more appropriate to pitch IICT to the level of a full-fledged university, not just catering to the limited field of carpets, but in general to the field of textiles, so as to be able to meet and achieve the basic needs of people that are embedded in the basic slogan of "*Roti, Kapda aur Makan*".



# CONSULTANTS

## Consultants

PROF. D.K. BANWET  
EMERITUS PROFESSOR,  
DMS, IITD  
CURRENTLY  
VICE CHANCELLOR, UEM,  
KOLKATA

**Tel** 09891039832  
dbanwet@gmail.com,

DR. R. CHATTOPADHYAY  
PROFESSOR, TEXTILE  
TECHNOLOGY  
DEPARTMENT, IITD  
EX-PROF I/C PLANNING IITD

**Tel** 09871095892  
rabisankarc@gmail.com

KRISHNA KANT BAJPAI  
ASSOCIATE PROFESSOR,  
FMS, SMS, VARANASI

**Tel** 9839148223  
kkant@smsvaranasi.com

Dr. KK. Goswami  
Director  
Indian Institute of Carpet Technology

Chauri, Road, Bhadohi, Uttar Pradesh - 221401

**Tel** 05414 225504

**Fax** [Fax]

[www.iict.ac.in](http://www.iict.ac.in)



---

<sup>1</sup> A Brief Report on Textile Industry in India, July, 2015. Corporate Catalyst (India) Pvt. Ltd.,

# 5

## DETAILED PROJECT REPORT

# **Indian Institute of Carpet Technology (IICT), Bhadohi-221401**

**(Proposed EFC/SFC Phase-III for five years i.e. 2016-17 to 2020-21)**

## **1. Project Identification:**

### **1.1 Title of the project/scheme:**

Documentation for formulation of Phase-III EFC/SFC for expansion of **Indian Institute of Carpet Technology, Bhadohi, U.P.**

### **1.2 Name of the sponsoring agency (Ministry/Department/Autonomous Body/ Central PSE):**

Government of India, Ministry of Textiles, Office of the Development Commissioner (Handicrafts)

### **1.3 Proposed duration of the Project :**

2016-17 to 2020-21 (five years)

### **1.4 Total Cost of the project over the proposed duration :**

Rs.68.42 Crore (Rupees Sixty Eight crore & Forty Two lakhs)

## **2. Project Status:**

### **2.1 Please indicate which category the project belongs to:**

- (a) Continuing scheme from past plan periods and included in current plan period.
- (b) New Plan Scheme included in the current Plan period
- (c) New Plan scheme not included in the current Plan period
- (d) RCE proposal

The scheme belongs to category 2.1 (a)

### **2.2 If project pertains to category 2.1 (a), Please summarize the benefits already accrued and expenditure already incurred along with an independent evaluation of the past performance of the project scheme:**

Indian Institute of Carpet Technology (IICT) has become academically functional with effect from 01.11.2001 exactly within the stipulated targeted schedule. The functionality marked with the initiation of first ever class room activity for the 1<sup>st</sup> semester B. Tech. Students in the branch of Carpet & Textile Technology (CTT) duly **approved by All India Council for Technical Education (AICTE) and affiliated to the then Dr. A.P.J. Abul Kalam Technical University formally Uttar Pradesh Technical University.**

Thereafter, IICT decided its portfolios through which service to the industry and stakeholders duly provided. The descriptions, achievements etc. are available through enclosed documents. However, the summary of utilization of HRD is as under

**Utilization of B. Tech. Graduates:** IICT Bhadohi is conducting B.Tech. Course in Carpet & Textile Technology from the year 2001 and **11 Batches** have come out successfully with a total of 373 graduates in the related trade. After completion of their course, the students are supposed to join any reputed organization related to Textiles/Carpets/Wool Industry. In this regard, the Placement cell of the Institute is dedicatedly involved for providing jobs to all outgoing students well before completion of their course. In addition to the same, some students opt for higher education like M.Tech/MBA/Fashion Tech. from the leading Institutes. An overall report of B.Tech. Graduates passed out from IICT Bhadohi are as under:-

1. All most 80-85% of the passed out graduates are serving leading Textile and Carpet Industry, the names of few are as under:-  
M/s Vardhaman Textile Ltd, Ludhiana, Nahar group of companies, Ludhiana, Alps Industries, Meerut, Alok Industries, Silvasa, Gujrat Ambuja, Gujrat, Raymond India, Valsad, RSWM, Bhilwada, Paliwal exports Panipat, Shahi exports Faridabad, Orient Carpets Bhadohi, OBEETEE Pvt. Ltd, Gopiganj, Raj overseas, Panipat, ABC Carpet, Mirzapur, Wires & Fabrics, Kolkata and many more.
2. All most 10-15% of the passed out graduates are opting higher education from world's leading Institutions, the names of few are as under:-  
IIT Delhi, IIT Kanpur, IIT Bombay, IIT Kharagpur, NITIE Bombay, UDCT Bombay, NIFT Delhi, NIFT Bangalore etc.
3. Rest 0-5% of the passed out graduates are either self employed or chosen other Industry like Banking, Software etc.

**Utilization of other trainees:**

Under various schemes IICT has created artisans in the form of skill development and or upgradation. The list of trainees has been sent to CEPC, AICMA, EUPEA and MCMA for utilization by potential employer. The information on availability of trained unemployed carpet weavers to the tune of 2000 which include 1200 females weavers, of ages 20-40. Interested employer may contact M/s Unnayan Sansthan, Chunar. Some glimpses of female weavers receiving training are reproduced below-



**Fig. 1**  
Female weavers under training at IICT, Bhadohi

**Details of year wise grant received and grant utilized for SFC of Phase-II:**

(Rs. In lakhs)

Year	Grant Released		Grant Utilized	
	Non-recurring	Recurring	Non-recurring	Recurring
2005-06	130.00	80.00	Nil	Nil
2006-07	150.61	163.77	Nil	169.00
2007-08	Nil	Nil	14.88	157.21
2008-09	127.72	335.00	51.16	168.36
2009-10	Nil	Nil	234.35	205.39
2010-11	82.79	356.00	54.84	213.09
2011-12	42.41	256.36	174.57	222.75
2012-13	180.00	100.00	30.65	220.80
2013-14	Nil	Nil	54.09	--
2014-15	Nil	Nil	19.91	--
2015-16 (4/2015 to 16-11-2015)	265.56	65.47	156.00	--
<b>Total</b>	<b>979.09</b>	<b>1356.60</b>	<b>790.45</b>	<b>1356.60</b>

**Allocation of SFC Phase-II:**

(Rs. in lakhs)

Particulars	Sanctioned Amount	Released Amount	Spent	Fund available in SFC-II
(1)	(2)	(3)	(4)	(5) 2-3
Non-Recurring	1143.00	979.09	790.45	163.91
Recurring	1356.60	1356.00	1356.60	--
<b>Total</b>	<b>2499.60</b>	<b>2335.69</b>	<b>2147.05</b>	<b>163.91</b>

The need for further expansion of IICT has been felt by all corners including industry & university (**copy of resolution of Executive Committee of IICT is enclosed – Annexure-I**)

On the issue of further expansion of IICT and preparation of EFC/SFC-III, & subsequent engagement notice to M/s. LICI, Kanpur as well as minutes of the internal meeting involving IICT staff members are annexed (**Minutes of meeting IICT staffs on Phase-III-Annexure-II**)

On the above background IICT provided all available inputs in well-documented form. M/s LICI, Kanpur the then engaged and approved consultant, who in close coordination with all concerned verified this document with respect to the civil work of the proposal including cost estimates etc and issued forwarding letter cum endorsement in the form of email (**copy of LIC email on NR BE & Master Plan enclosed-Annexure-III**) as independent/ body for onward submission to the Office of Development Commissioner (Handicrafts) for subsequent action.

**In addition, as per direction received from higher authorities- A.S.& F.A., Development Commissioner (HC), Divisional Commissioner, Vindhyachal Mandal etc., to attain the objective of Swachh Bharat Mission, Greening, Rainwater Harvesting, Solar Energy Generation etc. & emerging needs, the additional estimated cost amounting to Rs.448.46Lakhs has been included in the proposed Non-recurring Expenditure plan under EFC Phase-III.**

#### **INTRODUCTION IN RETROSPECT:**

The institute was originally sanctioned Rs.18.04 crore to meet non recurring and recurring expenditure in Phase-I of the project. Thereafter, high power Committee met at Udyog Bhawan on 13.03.2006 and 02.02.2007 chaired by the then Secretary (Textiles) and The discussion was initiated observing success of the Phase-I and after detailed discussion the EFC approved the proposed expansion of the institute in the Phase-II with certain stipulations. (**Minutes of the meeting enclosed - Annexure-IV**). It is therefore pertinent to provide a status of implementation of the various components of the project approved by EFC dated 02.02.2007 as under.

**Status of implementation of the various components of the project approved by EFC dated 02.02.2007**

<b>Sr. No.</b>	<b>Minute No.</b>	
1.	<b>Minute No. 1</b> <ul style="list-style-type: none"><li>• A fresh EFC Meeting over 13.03.2006 was to be convened.</li></ul>	Accordingly a fresh meeting was convened on 02.02.2007

Sr. No.	Minute No.	
	<p><b>Minute No. 2</b></p> <ul style="list-style-type: none"> <li>• In order to extend and update the available infrastructure including faculty need has been felt to introduce Home Textile Technology (HTT) and Textile Design Technology (TDT) as new subjects</li> <li>• The aggregate expenditure proposed on expansion on Phase II after year 2009-10 has been Rs. 24.99 crore (11.43 for NR and 13.56 for Recurring)</li> </ul>	<p>Institute has inducted HTT, TDT and Advances in Carpet Technology (ACT) as new disciplines in an integrated manner in the existing B.Tech Course with an intake of 60 students per batch.</p> <p>The project has undergone another SFC under the chairmanship of the then Secretary (Textiles) on 15.11.2011 with regard to the proposed modified expansion of IICT, Bhadohi (Phase-II) and the term of the project has been extended till 2015-16 within the original approved cost and certain re-appropriations.</p>
	<p><b>Minute No. 3</b></p> <p>Advisor (PAMD) felt that it was necessary to evaluated as to whether students passing out from the institution were finding employment in the market.</p>	<ol style="list-style-type: none"> <li>1. All most 80-85% of the passed out graduates are serving leading Textile and Carpet Industry, the names of few are as under:- M/s Vardhaman Textile Ltd, Ludhiana, Nahar group of companies, Ludhiana, Alps Industries, Meerut, Alok Industries, Silvasa, Gujrat Ambuja, Gujrat, Raymond India, Valsad, RSWM, Bhilwada, Paliwal exports Panipat, Shahi exports Faridabad, Orient Carpets Bhadohi, OBEETEE Pvt. Ltd, Gopiganj, Raj overseas, Panipat, ABC Carpet, Mirzapur, Wires &amp; Fabrics, Kolkata and many more.</li> <li>2. All most 10-15% of the passed out graduates are opting higher education from world's leading Institutions, the names of few are as under:- IIT Delhi, IIT Kanpur, IIT Bombay,</li> </ol>

Sr. No.	Minute No.	
		<p>IIT Kharagpur, NITIE Bombay, UDCT Bombay, NIFT Delhi, NIFT Bangalore etc.</p> <p>3. Rest 0-5% of the passed out graduates are either self employed or chosen other Industry like Banking, Software etc.</p>
	<p><b>Minute No. 4</b> Concerned expressed 'Location of Phase-II away from the Phase-I building'</p>	<p>In the reply , the then DC(HC) said that this have to be done because no land was available near Phase-I.</p>
	<p><b>Minute No. 5</b> <b>Stipulations</b></p> <ol style="list-style-type: none"> <li>1. The total cost of expansion would be Rs. 24.99 crore (11.43 for NR and 13.56 for Recurring)</li>   <li>2. IICT should initially consolidate the present intake of 60 students for two years, However, more numbers of modular courses on the line of modular employable skills (MES) for a duration upto 6 months or so covering Computer Applications, Information Technology, Management/Marketing/Entrepreneurship, Merchandising etc, relevant to the promotion of wool, carpet and textile industry shall be introduced by involving participation from trade and industry also.</li>   <li>3. Presentably IICT may continue with its increased</li> </ol>	<p>It is maintained. However, the project has undergone another SFC under the chairmanship of the then Secretary (Textiles) on 15.11.2011 with regard to the proposed modified expansion of IICT, Bhadohi (Phase-II) and the term of the project has been extended till 2015-16 within the original approved cost and certain re-appropriations (copy enclosed)</p> <p>Institute has consolidated the present intake of 60 students till date. As regards modular courses institute is running similar courses. In implementation the Integrated Skill Development Scheme (ISDS) and Compressive Handicraft Cluster Development Scheme (Plan) of D.C (Handicrafts) of Ministry of Textiles, G.O.I have been integrated. The participation from trade and industry have also been ensured.</p> <p>IICT to continue its present activity and</p>



Sr. No.	Minute No.	
	<p>intake of 60 students in CTT duly integrated with HTT &amp; TDT. However, further increase in the number of students would depend upon the need of the industry over a period of two years.</p> <p>4. For creation of proposed 26 posts, a proposal may be sent to JS (Pers). However, the institute should also introduce the system of engaging guest faculty wherever feasible.</p> <p>5. An evaluation of the course context, students placement &amp; impact on the industry should be done every 2 years by an independent agency</p>	<p>Instead of further increase in intake of 60 students in CTT, some new disciplin like M.Tech in Carpet &amp; Textile Management (CTM) may be added as are being proposed to be introduced through the proposed Phase-III expansion. Continuation of present activity / Continuation of present activity with additional activity proposed.</p> <p>Requisition has been placed to the office of D.C(HC) [copy enclosed]. Institute has already introduced the system of engaging guest faculty as well out source any person /agency for such services like gardening, sweeping, Security or secretarial serves etc.</p> <p>The evaluation is being done by independent bodies like UPTU, the affiliated University; AICTE the statutory approval body; NBA another statutory approval body; The Textiles Institute (Manchester, UK) International approval body; IGNOU-AICTE-UGC joint committee ; for respective teaching /training activity and Integrated Quality Systems like ISO-9001 and ISO 17025 for Institute as a whole and laboratory in particular respectively.</p>

**The schedule of implementation of the project components left unimplemented, if any:**

The project has undergone certain changes as evident from compliance note prepared on Status of Implementation of the Various Components of the Project approved by SFC 02.02.2007 and approved through further SFC under the chairmanship of then then Secretary (Textiles) on 15.11.2011. However, the highlighting changes are as under:

**a. Term of Project:**

It has been extended from 5 years to 10 years i.e. upto 2015-16

**b. Re-appropriate of fund under Non Recurring head**

Re appropriation of fund Rs. 677 lakhs under sub head – Civil Electrical and Miscellaneous covering hostel building, lecture theatre /workshop and staffs accommodation.

**c. Re-appropriate of fund under Recurring head**

Re appropriation of fund Rs. 313.60 lakhs under sub head –Miscellaneous contingency covering contractual utility services petrol and diesel, communication and telephone, extension activities, membership fees and other contingencies

**BACKGROUND:**

**An overview:**

Indian Institute of Carpet Technology (IICT), Bhadohi, set up of Ministry of Textiles, Government of India under the aegis of Development Commissioner (Handicrafts) needs no formal introduction as it has proven itself for what it was established. It was felt by Government of India in 70's that there should be some institute/training centre within the periphery of India's highest handmade carpet producing belt. The Institute, which could provide desired support in development of carpet and allied textile industry. Keeping this into view, the location of the Institute is made such that it is 35 km from Mirzapur, 15 km from Aurai and 20km from Gopiganj; all these areas are well recognized in the global map for the production of Hand made Carpets. The beginning of the institute was made in 28<sup>th</sup> November 1998, through a Registered society and became truly functional with effect from 1<sup>st</sup> November 2001 by starting a B.Tech. course in Carpet & Textile Technology. Hence, IICT family celebrates this day as “**INSTITUTE DAY**” on 1<sup>st</sup> November of every year. However, the Institute was formally dedicated to the nation on 11<sup>th</sup> May 2002 by the then Hon'ble Minister of Textiles in presence of other dignitaries and office bearers. The course is unique in the sense that the students get an opportunity to learn the technicalities involved in manufacturing of a carpet and a textile good as well, in a four year duration.

IICT Bhadohi works under following 4 portfolios:-

- a. Human Resource Development (HRD)
- b. Design Creation and Development (DCD)
- c. Research & Development (R&D)
- d. Technical Service Support to Industry (TSI)

a. **HRD:** Under HRD portfolio, the Institute runs B. Tech. course related with Carpet and Textile Trade. So far all B.Tech. graduates seeking employment are placed while some are

either self employed or opted for higher education in institute of repute like IIT's NIT's, NITIE, ISM etc. Under B.Tech programme in Carpet & Textile Technology trade, 179 students have already passed out so far and are serving Carpet, Textile & related industry.

At present the total intake in B.Tech. is 60 integrating Home Textile Technology(HTT) & Textile Design Technology (TDT) as specialization in addition to existing Carpet and Textile Technology (CTT), where in 20 students in each category shall be specialized.

The distance learning programme has recently drawn attraction from various parts of the country and study centres are being created. Other than this, some short term courses sponsored by various agencies (such as government and Industry) are also run to provide trained Human resource to the society. The integrated skill development scheme (ISDS) of Ministry of Textiles is one such kind of scheme, which has been sanctioned to IICT to create supervisor /master trainer to the tune of 2400 persons over a period of 5 years. The scheme has been launched to initiate training on carpet weaving, carpet yarn dyeing, computer and IT application for carpet industry , carpet yarn spinning, carpet designing etc related modules pertain to carpet manufacturing covering 117 trainees besides 106 persons to be trained in Malda Carpet Cluster of West Bengal duly supported by Govt. of West Bengal. A training program under Mega Cluster Scheme of Ministry of Textiles, G.O.I. is being started to train 5000 crafts person in coming three years covering Bhadohi-Mirzapur carpet belt.

**Table 1. Year-wise Description of B. Tech. students & their Placement status**

<b>Sr. No.</b>	<b>Financial Year</b>	<b>No. of outgoing B. Tech. Students</b>	<b>Placement of Students</b>
1	2001 - 2002	Commence of B. Tech Course	-----
2	2002 - 2003	-----	-----
3	2003 - 2004	-----	-----
4	2004 - 2005	19	100 %
5	2005 - 2006	12	100 %
6	2006 - 2007	16	100 %
7	2007 - 2008	12	100 %
8	2008 - 2009	33	100 %
9	2009 -2010	43	100 %
10	2010 - 2011	44	100 %
11	2011 - 2012	24	100 %
12	2012-2013	54	100%
13	2013 - 2014	48	100%
14	2014-2015	68	100%
<b>Total</b>		<b>373</b>	

**Year wise details of B.Tech. Students:**

Position of 1 <sup>st</sup> year Admission through AIEEE/JEE/Direct			Lateral Entry to 2 <sup>nd</sup> year Admission position		Position of passed out students	
Year	Intake	No. of enrolled students	Intake	No. Enrolled students	Year	Passed out Students (Enrolled)
2001	20	19	--	--	2001	Nil
2002	20	16	1	1	2002	Nil
2003	20	19	--	--	2003	Nil
2004	20	19	--	--	2004	Nil
2005	30	30	3	3	2005	19 (19)
2006	60	48	--	--	2006	12 (16)
2007	60	44	6	5	2007	16 (19)
2008	60	24	6	3	2008	12 (19)
2009	60	54	6+4	10	2009	33 (30)
2010	60	57	6+15	21	2010	43 (48)
2011	60	60	6	6	2011	44 (44)
2012	60	59	12	12	2012	24 (24)
2013	60	60	12	12	2013	54 (54)
2014	60	60	12	12	2014	48 (57)
2015	60	59	12	12	2015	68(71)
<b>Total</b>	<b>710</b>	<b>628*</b>	<b>101</b>	<b>97</b>	<b>Total</b>	<b>373** (401)</b>

**\*Capacity utilization @88.45%**

**\*\* Retention of enrolled students @93.01%**

**Table 2. Details of running Training Programs as on date:**

Sr. No.	Nature of course	Status
1.	Short term training programmes - ISDS	<p><b>1138 trainees have been trained in following modules:</b></p> <p>CAD - 405 Trainees completed the programme.</p> <p>Computer &amp; Mgt- 199 Trainees completed in the programme.</p> <p>Dyeing- 95 Trainees completed in the programme</p> <p>Spinning of Woolen Yarn- 20 Trainees completed in the programme</p> <p>Washing &amp; Finishing- 80 Trainees completed in the programme</p> <p>Carpet weaving for hand- knotted / hand tufted/ loom made - 183</p> <p>West Bengal Govt. - 156 Trainees enrolled in the programme</p>
2	Imparting skill up-gradation to 5000 carpet weavers /artisans of Bhadohi-Mirzapur under Comprehensive Handicrafts Cluster Development Scheme (Plan)	<ul style="list-style-type: none"> <li>• 2050 Trainees have been trained.</li> <li>• Details have been communicated to CEPC, AICMA, Technopack all concern for utilization of their competency derived.</li> </ul>
3	Industry-driven special courses & IDLP Packages	54 enrolled

b. **DCD:** Under DCD portfolio, creation of new designs, modification and development of motifs related to carpet and textile is made using CAD softwares like Autotex and Nedgraphics. Design solution through Design Bank has been introduced which is gaining lot of popularity among Industry people. The bank is having more than 7000 designs from which around 500 designs have been utilized by industry for commercial purpose.

c. **R&D:** In R&D front, attempt is made to commercialize the products/developments/ technologies invented by the Institute. Some of the outcome of the R & D portfolio are Snehabha

Carpet Backing, India Knot, Natural coloration, Natural fiber carpet, Cross Bar Horizontal Loom, CARPCOST software and many more.

d. **TSI:** TSI portfolio is concerned about the testing, certification, trouble shooting and consultancy work related with the trade. It is proud to say that the testing laboratory of IICT Bhadohi is accredited to NABL conforming ISO 17025.

**Table 3. Description of the Testing Services conducted by IICT Laboratories**

<b>Sl. No.</b>	<b>Financial Year</b>	<b>No. of Testing Services Conducted</b>
1	2005 - 2006	1441
2	2006 - 2007	1815
3	2007 - 2008	1968
4	2008 - 2009	2002
5	2009 -2010	1377
6	2010 - 2011	1128
7	2011 - 2012	1012
8	2012 - 2013	1202
9	2013 - 2014	1073
10	2014-2015	1509
11	2015-16 till 26-03-2016	1007

To develop an interface with industry, a forum “Kaleen Bandhu” is working under which various Kaleen and related industries are members. Regular meetings are held where institute-industry works together to discuss and resolve the problems of industry. These members get preferential treatment from IICT to boost their trade.

Being an academic institute, IICT understands its duty to provide information and literature related with the new developments going on worldwide related with the trade. In this regard, many publications including books written by the Director of the institute are offered to the Industry, which are being useful for the Stakeholders. Similarly, a good number of patents and Trade marks are also in the credit of the Institute.

IICT Bhadohi has been awarded UPTU Excellence Award twice as a star performer. The students of the institute have received Gold and Silver medals from the university in their academics.

Time to time, Extra ordinary Personalities from society, administration, press/media and political background have visited the institute. Motivational words of appreciation are received from these dignitaries, which inspires the whole IICT family in taking new initiatives.

The Director of the Institute, Prof (Dr) KK Goswami, who is also the founder Director has a vision to see the Institute as a Centre of Excellence and a consistent Endeavour is made by him and his dedicated team with due guidance of Chairman & Vice-Chairperson to reach the Institute to comply with the requirements of international standards for all its portfolios.

Over a decade, IICT has contributed through its established portfolios particularly in HRD & R&D to a great extent to meet the existing gap. Thus IICT is committed to support the trade to take it to new heights in all relevant fronts.

**Journey of IICT since 2002:**

IICT was dedicated to the Nation by the then Hon'ble Minister of Textiles, Govt. of India in presence of Hon'ble Minister of SSI, Govt. of UP on 11<sup>th</sup> May 2002 and international collaboration was established (Fig.1). Coveted Awards bagged are depicted in Fig 2 & 3. Honlbe Minister of State for Textile interacted with IICT students, faculty & industry in presence of DC (Handicrafts), Chairman, IICT & Director, IICT Fig. 4. Unveiling of ISDS booklet by launched by IICT (Fig.5). A team of The Institution of Engineers, Varanasi Local Centre, visited IICT for interaction (Fig.6)

## JOURNE OF IICT IN PICTURES



Fig. 1 Unveiling of the Dedication Stone by the then Hon'ble Minister of Textiles, in presence of all dignitaries, invitees, students and medias personnel's





**Mr. Ankit Kumar & Ms Shruti students of IICT are receiving Gold and Silver Medal for year 2010 respectively from His Excellency, Governor of UP, Chancellor, GBTU in presence of Ex-Chairman, ISRO, Dr. G. Madhavan Nair & other dignitaries**

**Award bagged by IICT**



Indian Institute Of Carpet Technology (IICT) Bhadohi, has been awarded UPTU Excellence award as a Star Performer. The award was received by Vice Chairman Dr. Sandeep Srivastava & Prof(Dr) K. K. Goswami, Director, IICT, from H. E. Governor of U.P. & Chancellor of U.P.T.U. in a celebration on the eve of inauguration of NOIDA Campus of UPTU on 14.2.2008. Shri Sanjay Agarwal, IAS, DC(Handicraft), Chairman IICT, Dr. Sandeep Srivastava ADC(Handicraft), Vice chairman IICT congratulated Prof(Dr) K.K.Goswami Director IICT & his team for their effort in achieving this rare height.

**Fig. 2, Fig. 3**

**Fig. 4**

Hon'ble Minister of State for Textiles flanked by Development Commissioner (Handicrafts),MOT,GOI (RHS) and Director IICT (LHS) addressing the IICT faculty, staffs, students and Industry



**Fig. 5**

Hon'ble Union Minister of Textile, Shri Anand Sharma, Smt Rita Menon, IAS thethen Secretary (T), MOT & Shri S.S.Gupta, IAS Development Commissioner (Handicrafts),MOT unveiling the ISDS Booklet launched by IICT,Bhadohi





**Fig. 6**

**A team of Varanasi Local Centre, Institution of Engineers (I), Varanasi visited the institute for interaction with students, faculty, staffs & industry**



**Fig. 7**

**Shri Satyajeet Thakur thethen Divisonal Commissioner Mirzapur lighted the lamp during one of the students cultural programme in presence of representatives of carpet industry.**



**Fig. 8**

**Mrs. Satyajeet Thakur & Satyajeet Thakur unveiling students magazine “tanabana” in one of the cultural programme of the decade in presence of Mr. Abdul Hadi the then Hony.Secretary ,AICMA representing carpet industry.**



**Fig. 9**

**Mr. Akhilesh Maurya (2012 batch) one of the brilliant students of IICT presently doing M.Tech from IIT Delhi is receiving compliment on the occasion of farewell party to the outgoing batch of 2012.**





*Fig. 10*

*The then district magistrate Mrs. Kanchan Verma is encouraging the students by means of unveiling students magazine “tanabana” in one of the cultural event of the decade*



*Fig. 11*

*IICT students performing yoga as a co-cultural activity in institutional programme.*



Fig. 12

*Industry invitees enjoying the cultural programme along with the students of IICT*



Fig. 13

*Students are enjoying the facility of new academic block created under phase II expansion project of the IICT*





Fig. 14

*M/s V.K.Sinha & S.K.Sinha Representative of CEPC & AICMA respectively are actively participating in prize distribution ceremony.*



Fig. 15

*A glimpse of green IICT through continuous endeavor of plantation*



Fig. 16  
Final year students of IICT ready to serve industry with effect from July 2013.  
Potential carpet industrialists may contact them and or Training and Placement Officer.



Fig. 17  
*Faculty and students are enjoying together in annual sports meet.*





*Fig. 18  
Winner team of sports activities 2011*



*Fig. 19  
M/s Bholanath Baranwal, R.K.Bothra and Shahid Hussain representing Carpet industry motivating one of the brilliant student of IICT in present of Director, IICT.*



*Fig. 20*

*Prof.Kripa Shanker , Hon'ble Vice chancellor of GBTU, grace the occasion of institute day,1<sup>st</sup> Nov-2011 to motivate IICT family for academic excellence.*



*Fig. 21*

*Students & invitees are enjoying the cultural programme in the form of song sung by Professor cum consultant of IICT B.D.Dixit.*





Fig. 22

Shri Satyajeet Thakur, IAS the then Divisional Commissioner, Mirzapur discussing with M/s Avinath Baranwal, Virendra Roy, Abdul Hadi and Surendra Baranwal representing carpet industry while Director IICT was present.

Table 1



**Fig. 23**

Plantation by HMOT Dr. K.S.Rao, Shri S.S.Gupta, IAS DC(HC), Chairman, IICT & Shri Lalitesh Pati Tripathi, MLA, Marihan



**Unveiling of Placards containing Role, Achievement etc of IICT by HMOT**



**HMOT being briefed by Director IICT about the placards containing Role, Achievement etc of IICT unveiled by him**

**Fig. 24 & 25**





**Inspection of Carpet Testing Lab equipments by HMOT & DC(HC), Chairman, ICT**



**Inspection of Carpet Testing Lab equipments by HMOT & DC(HC), Chairman, ICT**  
**Fig. 26 & 27**



**Director, IICT presented a book entitled “Process Control in Carpet Manufacturing” authored by him to HMOT**



**Display of Design Bank to HMOT  
Fig. 28 & 29**





**Inspection of Looms by HMOT developed by IICT**  
Fig. 30 & 31

# मंत्री ने लिया आइआइसीटी का जायजा

- प्रशिक्षण कार्यक्रम को विस्तार देने पर बल
- संस्थान के प्रयासों की सराहना, मदद का आश्वासन

**भदोही :** केंद्रीय कपड़ा मंत्री डा. केएस राव ने रविवार को भारतीय कालीन प्रौद्योगिकी संस्थान (आईआईसीटी) का जायजा लिया। इस दौरान संस्थान द्वारा कालीन उद्योग के विकास के संचालित किए जा रहे विभिन्न तकनीक से उन्हें अवगत कराया गया।

कपड़ा मंत्री वाराणसी से सीधे इंदिरा गिला स्थित संस्थान पहुंचे। पहले इंतजार कर रहे संस्थान के निदेशक डा. केके गोस्वामी सहित कर्मचारियों ने उनका गार्मजोशी से स्वागत किया। इस दौरान संस्थान द्वारा विकसित तकनीक के बारे में श्री राव को जानकारी दी गई। लगभग एक घंटे के विविध के दौरान कालीन उत्पादन सहित अन्य तकनीकी पहलुओं से उन्हें अवगत कराया गया। साथ ही आईआईसीटी के आगामी योजनाओं के बारे में भी बातला गया। निदेशक डा. गोस्वामी की मांग पर (आईएसटीएफ) के तहत ट्रेनिंग पाने वाले प्रशिक्षुओं की लगने वाली 27 पीसद पीस भी भाष्य करने का अनुरोध किया। कहा कि आइआइसीटी कालीन उद्योग के लिए बेहतर प्रयास कर रही है। इसका लाभ उद्योग को उठाना चाहिए। साथ ही प्रशिक्षण



केंद्रीय कपड़ा मंत्री डा. केएस राव के आगमन पर उपस्थित गणमान्य लोग।

कार्यक्रम को और विस्तार देने पर बल देते हुए कहा कि संस्थान के इंचलपमेंट के लिए मंत्रालय से हर संभव सहायता उपलब्ध बनाकर देने का है। योजनाओं के लिए प्रस्ताव बनाकर भेजने को कहा।

इस दौरान संस्थान परिसर में पौधरोपण कर पर्यावरण संरक्षण के प्रति बिम्बेदाश्री का परिचय दिया। उनके साथ मडिहान (मीरजापुर) के विधायक ललितेश पति त्रिपाठी, जिला-उद्योग निर्मात प्रबंधक डा. एडी त्रिपाठी, उर्जा/जलाधिकारी श्रीराम, एसी बरनवाल, तनवीर हुसैन अंसारी सहित कई कार्यरत नेता व उद्योगी रहे।

## आफसरो व उद्योगियों से भरा रहा हाल

**भदोही :** केंद्रीय कपड़ा मंत्री डा. केएस राव के आगमन पर मंडलायुक्त एसएन शकुना, जिलाधिकारी चंद्रकान्त पांडेय, उमेश कुमार गुप्ता गुप्ता, शोकत अली अंसारी, राजाराम गुप्ता, कमरुद्दीन अंसारी, हाजी जलील अंसारी, शिबसागर तिवारी, हाजी नसरुल्लाह अंसारी, रजा खा, अब्दुल रब अंसारी, अब्दुल सत्तार अंसारी, इरिफाक खा अफ्ट, भरत लाल मीन, सूर्यमणि तिवारी, अरसाद बजीरी, इरिफाक सिद्दीकी, शिबसागर तिवारी, आनंदक अंसारी, एसएन मीन, जेजी गुप्ता सहित

## कालीन भेंट कर मंत्री का स्वागत किया

**भदोही :** केंद्रीय कपड़ा मंत्री डा. केएस राव को सीईपीसी के प्रशासनिक सदस्यों ने बुके व कालीन भेंट कर स्वागत किया। वरिष्ठ, प्रशासनिक सदस्य उमेश कुमार गुप्ता, वशिष्ठ अंसारी, ओकरनाथ मिश्रा बच्चा, भरतलाल मीन, इरिफाक खा अफ्ट, राजाराम गुप्ता ने उद्योग परिदृश्य में प्रथम आगमन पर अभिनंदन किया।

## खचाखच भरा रहा एकमा हॉल

**भदोही :** सीईपीसी द्वारा आयोजित कार्यक्रम के दौरान मंडलायुक्त कालीन भवन पूरी तरह भरा रहा। हाल में परे रखने की वजह नहीं रही। यहाँ तक कि कई कालीन निर्मातक व अधिकारी बस्तर ही टहलते रहे। दरअसल कपड़ा मंत्री के आगमन को लेकर उद्योगों का उत्साह था।

## दर्जनों निर्मातक मौजूद रहे।

कपड़ा मंत्री के कालीन भवन आगमन पर सीईपीसी के चेयरमैन सिद्धनाथ सिंह व एकमाध्यक्ष ओकरनाथ मिश्रा ने उनका स्वागत किया। इस मौके पर विकास आयुक्त (डीसी हैटिंग्स/एफ्ट) शिबसागर गुप्ता ने प्रशिक्षण केंद्रों को विस्तार देने पर बल दिया। सिद्धनाथ सिंह, विमल कपूर, ललितेश पति त्रिपाठी, अब्दुल हादी ने उद्योग को समर्थना से मंत्री जी को अवगत कराया। संचालन प्रकृमा के मानद सचिव तनवीर हुसैन अंसारी ने किया।

Fig. 32



Shri Alok Kumar, IAS, Development Commissioner (Handicrafts) & Chairman, IICT visiting IICT for attending 52<sup>nd</sup> SGM and institute day celebration on 1-11-2015.

Fig. 32



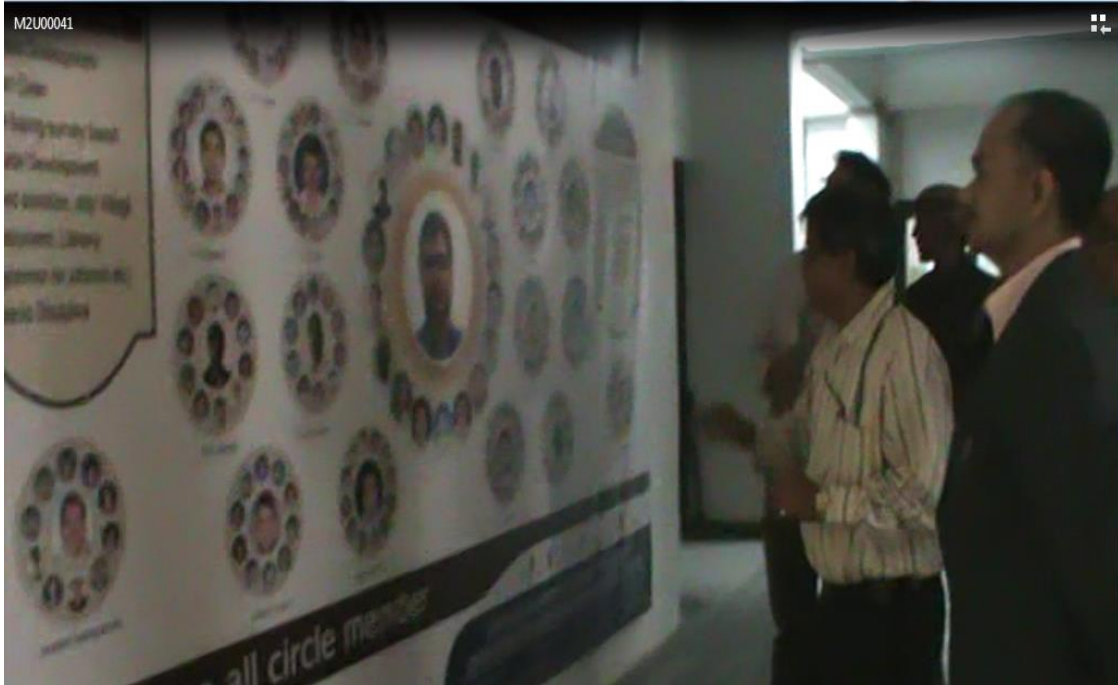

**Inspection of Quality Circle at IICT by DC(HC), Chairman, IICT on 1-11-2015**

**Fig. 33**



**Inspection of Workshop of IICT by Development Commissioner (HC) & Chairman, IICT on 1-11-2015.**

**Fig. 34**



Development Commissioner (HC) & Chairman, IICT, Divisionla Commissioner, Vindhyachal Mandal & Vice Chairman, IICT & others during 52<sup>nd</sup> SGM of IICT on 1-11-2015

Fig. 35



Shri J.K.Dadoo,IAS, A.S.& F.A., during meeting with Director, IICT & Director (HC), Vice Chairman, IICT & Staff of IICT.

Fig. 35



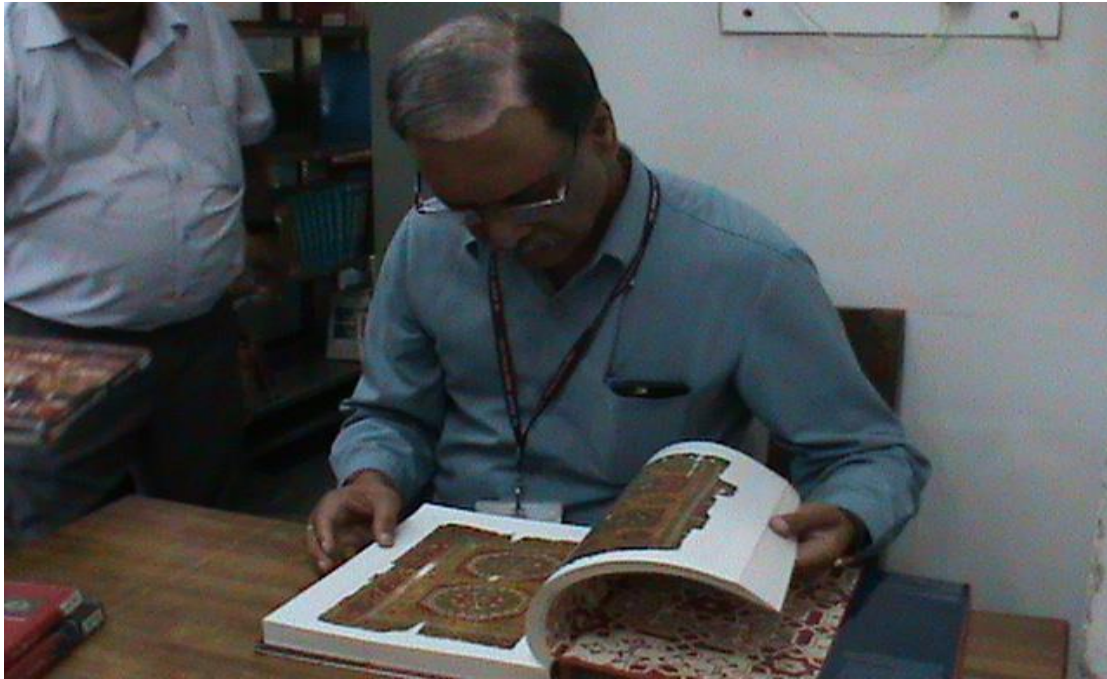

**Shri J.K.Dadoo,IAS, A.S.& F.A., during inspection at IICT Library.**

Fig. 36



**Shri J.K.Dadoo,IAS, A.S.& F.A., during inspection at IICT Workshop.**

Fig. 37



Speakers sharing a common philosophy

A view of August gathering

Dr. K.K.Goswami, Director, IICT having discussion during the seminar with Shri Vijay Thakur Ex-Chairman, CEPC, Mr. Farhad Vani, GIZ GMBH, Germany and Ms Astha Garg

## August gathering taking view of natural dyes



Appreciating presentation of Astha Garg



Exhibition- High Knottage Recreation of Tehran design in 100% Natural Vegetable Dyes



Dr. K. K. Goswami With his colleague Dipankar Jana

Ms.Astha Garg addressing to the audience her views about natural dyes

Exhibition – High Knottage Recreation of Tehran Design in 100% Natural Vegetable Dyes

Prof. K.K.Goswami, Director, Indian Institute of Carpet Technology, Bhadohi and his colleague Mr. D.Jana spreading their views about natural dyes

**Fig. 39 to 42**  
Glimpses of Seminar on RENAISSANCE IN NATURAL VEGETABLE DYES jointly organized by India International Centre & Cottage Craft of India on 2<sup>nd</sup> Sept, 2011 in association with IICT (An effort by Shri Vijay Thakur of CCI & Ex.Chairman, CEPC.

- 2. R&D of IICT for the benefit of Industry:
- 3. 3.1 Use of unexplored vegetable fibers in carpets



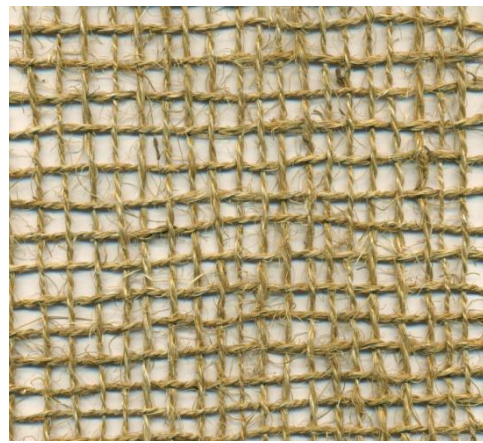
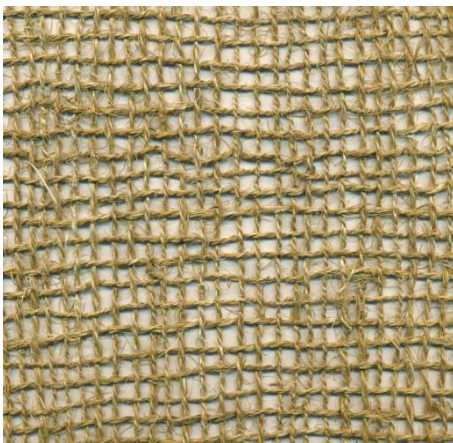

**Fig. 43 A view - Application of natural fibers for Home Textiles including floor coverings**

## SCRIM COIR FABRIC POTENTIAL FOR CARPET BACKING

Fig. 44

### 2.3.2 Development of artisans-friendly weaving system

Validated and accepted by industry due to reduction of drudgery and comfort to the weavers resulting improved quality and productivity

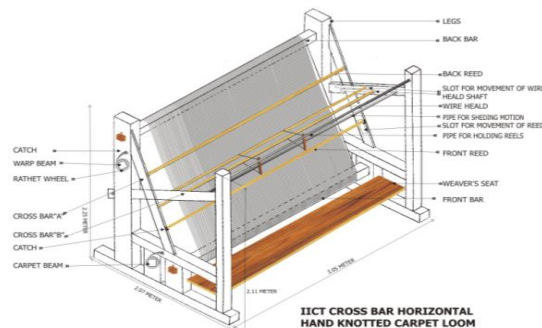

Fig. 45

**New Cross Bar Horizontal Loom: Patent obtained and commercialized:**

*Note: Interested fabricators are invited to contact for taking license for cost effective fabrication.*

### Development of new technique of Knot formation (India knot)

#### **India Knot:**

A new knot Pile Formation Technology in handmade carpet manufacturing. This also has been considered another milestone for the sector and licensing is in process. The technique & logo, both patented. Industry has come forward to take license for India Knot

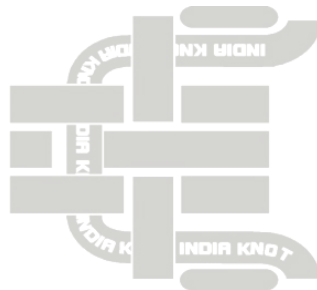

**Fig. 46: Depiction of India Knot structure**

It is evident that India Knot is very much superior from durability point in different constructional plan. Interested one may contact for taking license for commercial manufacturing and marketing. One can integrate jacquard into the system for enriched designs.

## Substitution to latex based backing: Snehabha Carpet Backing

Innovation of carpet backing system (Snehabha Polymeric sheet & Carpet Backing System) which have been patented & registered for the trademark and covered under copyright. Industry has considered this innovation as a milestone for the handmade carpet industry. MSME, Govt. of India has taken step to create a common facility centre involving govt. of UP and M/S Bhawana Ltd as a SPV partner considering this is absolutely new & risky concept but novel with unique setting proposition.



**Fig. 47 Prototype Carpet Backing Machine**

### **Salient features:**

- Polymeric backing instead of the latex
- Eco-friendly
- Light weight
- Washable
- Cost effective

**Software for cost control: CARPCOST** Development of CARPCOST: A software for cost management. Software is being covered under Copyright. It has been given to interested industry personnel for their commercial trial and feedback. One can contact IICT for further details. The price of the software is reduced to Rs. 5000.00 significantly from existing Rs. 25,000/- to make the software more accessible by industry. All interested stakeholders are invited to take advantage of this



development.

**Fig. 48 Web view of the software**



## Hand made Astrotuft-1 Billion \$ market for Indian carpet exporters.

Statistical information/background:

Base Data:

Earth surface area = 5,11,821.3 billion m<sup>2</sup>

World land area = 148940 billion m<sup>2</sup>

Indian land area = 2973 billion m<sup>2</sup> (1.99% of world)

Potential & Prospects

Financial market = 250 x 20 bn \$ = 5000 \$bn @20\$/m<sup>2</sup> of product price.

Present export value of Indian carpets = 0.85 bn\$.

If Indian carpet industry takes share of artificial turf @only 0.02% the market size will be Billion \$ which is more than or equal to the existing market size



**Fig. 49**

**Sample of Artificial Turf vis-à-vis Handmade Artificial Turf- A huge potentiality.**



**Secretary Textiles, MOT Smt. Rashmi Verma, IAS, at IICT.**

**Fig 50**





**Inspection of Campus of IICT by Secretary (MOT) and Development Commissioner (HC) & Chairman, IICT.**

Fig 51



**Secretary Textiles, MOT and Development Commissioner (HC) & Chairman, IICT, during inspection at IICT Workshop.**

Fig 53

## Documentation/Publication:

IICT has many publications including books which are mentioned below. The documents may be very useful for the industry. Stakeholders are requested to come forward to utilize the facility available in IICT.

- (i) Dr. K.K.Goswami authored a book entitled “Advances in Carpet Manufacturing” published by M/s Woodhead Publishing House, UK in association with The Textile Institute, Manchester in 2010.
- (ii) A book entitled “Process Control in Manufacturing Home Textiles including carpet” authored by Prof. K.K.Goswami published by M/s Abhishek Publications, Chandigarh.
- (iii) A book entitled “Process Control In Carpet Manufacturing” authored by Dr. K.K.Goswami published by M/s Abhishek Publications, Chandigarh. The Hindi version of this book is also available in market.
- (iv) A book entitled “Performance Measurement of Handmade Carpet Industry” facilitated the research work by Dr K.K.Goswami M/s Abhishek Publications, Chandigarh.
- (v) 2<sup>nd</sup> edition of book entitled “Advances in Carpet Manufacturing” under process.

## **SALIENT NATIONAL AND INTERNATIONAL PUBLICATIONS:**

More than 70, includes publication in International Journals like AATCC, The Innovation Journal, The Indian Textile, Textile Asia, Melliand Textile Berichte

**A BOOK ENTITLED 'ADVANCES IN CARPET MANUFACTURE' EDITED BY DR. K.K.GOSWAMI**

## Press clips about documentation on MES



## PATENTS & TRADE MARKS:

1. A patent vide no 211274("New Polymer Sheet and method of backing carpet or such thick fabric material with the new polymer sheet" awarded
2. Another patent vide no 214269 on the title "A New Carpet Backing Machine to back carpet or such thick fabric material" awarded
3. Two trademarks vide nos 1478866 & 1478867 on " carpet backing obtained.
4. A patent application vide no. 34/Kol//2008 on a method of weaving carpet in Handloom system by a new knot/pile weaving structure' submitted
5. A trade mark vide no. 1634428 on Handloom made carpet as India knot obtained.
6. A patent vide no. 253318 (Cross Bar Horizontal Hand Knotted Carpet Loom having inclined Warp Path) obtained.
7. Method of regenerating cellulose from coir fibre vide application no.149/KOL/2012 submitted.
8. Patent application No.3755/DEL/2015 dated 17-11-2015 "Method of developing sprout/stretch resistant pile integrating terry & leno mechanism for producing value added towel & carpet" submitted.



## Views of visitors:

### 2.6.1 Comments of the Visitors (Abroad) visited institute/ stall during Expo:

Name & Address	Comments
Rahmatullah Garden Khawarizma Aedalus@du M.N. 9415303933	Total design choosed by me
Nigel Atkinson, Nigel Atkinson Studio, 4 CAMDEN SQUARE, LONDON NW1 9UY. www.nigel-atkinson.co.uk. nigel@nigel-atkinson.co.uk.	Very encouraging to see the creativity and clarity of the work.
Expo - 2012	
Name & Address	Comments
Dr. Parviz Nayyeri experts@setabro.com Iran	Impressive technology and methodology.
Jarvis Rugs Co 73 Jarvis St Toronto Canada Email Jarvisrugs@primus.ca	Excellent. received CA @ no cost

Date	Name & Address	Comments
22/11/2014		<p>मैं आप का एक प्रश्न केड में आज मैं का कार्य देखना (अभिप्रेत है। मैंने अपने इंटरनेट जाल के पिछले कार्य कार्ड में मैं के निवास के लिए प्रयास किया था उते देखने में बहुत ही जर्न महसूस हो रहा है कि मैंने एक निवास के बारे में बहुत ही उत्तम कार्य का (हकी। आप मैं के कार्य (अधिकारी को से जारी हुई। जारी के शीतल नियुक्त हुए हैं निर्णय लिया गया है। मैंने इस निवास का निश्चय एक आरबीय डेवेलपमेंट प्रदाताओं निवास बनाया है। उते कार्य के लिए हमारे प्रयास में आप का सहकार्य महत्वपूर्ण है। मैंने एक प्रयास किया है। इसलिए मैं निवास डेवेलपमेंट को उत्तम से उत्तम प्रयास दूंगा। मेरे लिए मैं एक उत्तम प्रयास करूंगा। इस कार्य में आपकी एक योग्यता की मैंने आपके साथ मैंने बहुत ही उत्तम प्रयास किया है।</p> <p>श्री 3 के साथ मैंने</p>

Date	Name & Address	Comments
05/09/2014	Navendra Shanker Pandey Distt. Magistrate SRN Bhadohi	Visited today on the auspicious day regarding Teacher's day. In the detail conversation, I felt students friendly and director are in teaching spirit. Students are quite intelligent & diligent at the same time. There is good scope for enhancement of the standards of Sush. I wish the best for all good things. [Signature]
09/01/2015	Dr. Martin Kunz Postava GmbH Germany/NK 305864574 (passport)	It is impressive to see the good progress achieved in the year since my last visit. Ad. Thank you for your continued support & signature M.K.
	MARCIANNE LANDRETTTEL PROLANA GmbH 305863230 (passport)	Thank you for your kind and explanation. It has been a most helpful, interesting and educational afternoon. M. Landrettel

Date	Name & Address	Comments
10/1/15	JK Dadas IAS Add Secy & Financial Advisor Min. of Commerce & Textiles	A pioneer institute in Compet. technology. Has needs application facilities in classrooms, testing labs, teaching infrastructure. Sush. Bharat is a minority group, I am watching the slow energy generation, import pits must be done. Have fruit trees & flowering plants are reqd. More customs at in K.D. projects, full-time training & self-help groups, and maintenance of Khushi record is important. He should not shine in excellence become an institute of National members by best wishes JK Dadas 10/1/15

**Message of Prof. Kripa Shanker, Vice-Chancellor, Gautam Buddha Technical University, Lucknow.**



गौतम बुद्ध प्राविधिक विश्वविद्यालय  
(पूर्ववर्ती उत्तर प्रदेश प्राविधिक विश्वविद्यालय)  
**Gautam Buddha Technical University**  
(Formerly Uttar Pradesh Technical University)



आई.ई.टी. परिसर, सीतापुर रोड,  
लखनऊ-226 021 (उ० प्र०) भारत  
I. E.T. Campus, Sitapur Road,  
Lucknow-226 021 (U.P.) India

प्रो० कृपा शंकर  
कुलपति  
**Prof. Kripa Shanker** Ph.D. (Cornell)  
Vice Chancellor

Dated :28.10.2010

**MESSAGE**

I am delighted to know that Indian Institute of Carpet Technology, Bhadohi is publishing the student's magazine "Tana-Bana".

The regular Co-curricular activities like brainstorming sessions, seminars, workshops, publication of student's magazine and other literary activities are ideal medium for the student to manifest creativity and give expression to their thought process. I hope that the publication of the magazine will go a long way in educating students in the field of creative writing and expression, subsequently leading for their overall personality development.

I convey my best wishes for the successful publication of the Magazine.



(Prof. Kripa Shanker)  
Vice Chancellor



**Message of Dr. R.K.Khandal, Vice-Chancellor, Gautam Budhha Technical University, Lucknow** (formerly Uttar Pradesh Technical University).

Dr. R.K. Khandal  
Vice Chancellor



**GAUTAM BUDDH TECHNICAL UNIVERSITY**  
(Formerly Uttar Pradesh Technical University)  
I.E.T. Campus, Sitapur Road, Lucknow-226 021 (U.P.)

Dated : 01.11.2012

Sub.: Celebrations of 12<sup>th</sup> Institute Day on 1<sup>st</sup> Nov. 2012 by IICT; Our Message

Dear Prof. Goswami,

It is a matter of great pleasure to note that the faculty and students of IICT would be celebrating their Institute day, today. It would have been my honour to be personally present amongst you on this occasion but I am sorry to say that I would not be able to make it in spite of my keen desire to do so. Due to certain unforeseen reasons, I have to beg your pardon at the last moment.

In order to register our appreciation for your efforts, I would like to express that:

- (i) The social activities, such as 'Blood Donation', 'Creating awareness of Care & Fare School Children from carpet weavers' families etc. by students of IICT, are commendable.
- (ii) Director IICT and his whole team deserve kudos for the praise-worthy record of academic performance of the students. University acknowledges it as a remarkable achievement of IICT.
- (iii) The demand of change of name from "Indian Institute of Carpet Technology (IICT)" to Indian Institute of Carpet and Textile Technology (IICTT) seems relevant and worth considering.
- (iv) The plans of IICT to start new courses i.g. 'B.Tech in Fashion and Apparel Technology' and 'M.Tech in Textile Management' are appreciated. G.B. Technical University will provide all possible support necessary to affiliate these courses, in public interest.
- (v) Considering the research and academic potential, G.B.T.U. would encourage IICT for Pre-Ph.D mentoring/examination centre to promote scholastic activity.
- (vi) G.B. Technical University will extend all possible support for students and faculty.

With the above statements, I wish IICT - 'An Institute with difference' functioning under the dynamic leadership and administrative control of Development Commissioner (Handicrafts) Ministry of Textiles, Govt. of India, a huge success in all its endeavours. Under the stewardship of Prof. Goswami, I have no doubt that IICT will certainly become a true international academic/research/referral centre in textiles.

I wish 12<sup>th</sup> Institute day a success and many happy returns of the day.

*R.K.Khandal*  
11/11/2012  
(Dr. R.K. Khandal)  
Vice Chancellor

Prof. (Dr.) K.K. Goswami  
Director  
Indian Institute of Carpet Technology (IICT)  
Chauri Road, Bhadohi-221401

Phones : (Off.): +91-522-2732194, (Fax): +91-522-2732189, (Res.): +91-522-2731631  
Email : rkhandal@upty.ac.in, vc@upty.ac.in Website: www.upty.ac.in

# Comprehensive Achievements note:

## Design Creation & Development (DCD)

Institute has got full fledged state of the art Design Studio & CAD Centre to take up Design Creation & Development Work to serve Wool, Carpet & Textile Industry.

### Design / Naqsha creation for the Industry

Utilization of CAD facilities for Research & Services over design for industry

Training: Potential designers are being trained who are either self employed or employed

Design Bank: State of the art reference/ search engine suitable for various carpet constructions

डिजाइन सेवाओं का वितरण

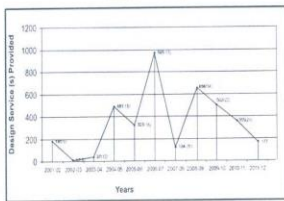

## Technical Service to Industry (TSI):

Institute can serve the related industry covering wool, carpet & textiles

Sample Testing & Certification: Laboratory (Carpet & Textile : Physical & Chemical) serves the industry over the years.  
Laboratory Accreditation (NABL) : Mechanical & Chemical Consultancy: Technical & Management consultancy to Industry directly and through sponsored projects covering Troubleshooting also.

Workshop: Facilities created is capable of research & development of various samples :: Yarn : Cotton, Woollen, Dref, Openend, Carpets : Handmade, Loom & Machine made. Fabrics: Woven, Jacquard, Terry & Chemical Processing: Dyeing of fibre to fabric, finishing of fabric & Carpet includes Innovative Backing of Carpets & Such thick Fabric materials.

### परीक्षण सेवाएं उद्योग को तकनीकी सहयोग (टी.एस.आई.)

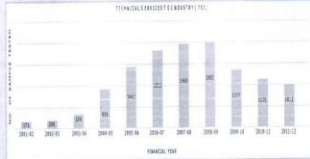

06 Consultancies/ Technical Services Provided.

ISO 9001:2008 Certified by SGS U.K.

For details on time frame & charges for the services refer "Tariff Schedule" and visit website: <http://iict.ac.in>  
Kindly Contact Director IICT for further clarification & Assistance



**INDIAN INSTITUTE OF CARPET TECHNOLOGY**

(Under the aegis of the Development Commissioner (Handicrafts), Ministry of Textiles, Govt. of India)  
Affiliated with U. P. Technical University & Approved by AICTE, Ministry of HRD, Govt. of India  
Char Road, Shadab, 201401 Tel: 15414 22554, Fax: 15414 22559  
Email: [info@iict.ac.in](mailto:info@iict.ac.in) Web: <http://iict.ac.in>





IICT is promoted by Ministry of Textiles, Govt. of India under the aegis of Development Commissioner (Handicrafts). It has become academically functional in 2001 through commencement of first ever Degree Course i.e. B. Tech in Carpet & Textile Technology unique of its kind.

- IICT is approved by All India Council for Technical Education (AICTE) and affiliated to U.P. Technical University (UPTU).
- IICT is approved by Central Counselling Board & All India Engineering Entrance Examination of Ministry of HRD Govt of India Technical for admitting B. Tech Aspirants
- IICT is accredited by the Textile Institute, Manchester, UK.
- IICT is awarded coveted ISO 9001:2000 in the year 2005 by SGS, UK.
- Accreditation by National Accreditation Board for Laboratory (NABL) for Mechanical & Chemical Laboratories of IICT.
- IICT operates on undermentioned four portfolios.

## PORTFOLIOS WISE ACTIVITIES / ACHIEVEMENT

### Human Resource Development (HRD)

#### A B Tech in Carpet & Textile Technology:

The course is at present limited to Indian Nationals. Possibility of admitting NRI/PIO/ foreign students is being explored with the concerned authorities. Curriculum details are available on the Institute's website.

Internship available with Industry: Local, Carpet, Wool, Textile and All India basis

Placement : Through Placement Cell /Professional/Campus Interview

Additional Disciplines like Advances in Carpet Technology (ACT) Home Textile Technology (HTT) & Textile Designing Technology (TDT) have been integrated as specialization in the final year.

Graduated : 209/ Placed : 80 to 85% Under Graduation : 165

#### B International Distance Learning Programme (IDL/P):

7 diplomas and 30 certificate course on wool, carpet & textiles are offered under the programme. Possibility of admitting NRI/PIO/ foreign students is being explored with the concerned authorities. Curriculum details are available on the Institute's website.

1. Diploma in Basic Textile Technology (Six Certificates Topics)
2. Diploma in Wool Scouring Technology (Six Certificates Topics)
3. Diploma in Textile Dyeing and Finishing (Six Certificates Topics)
4. Diploma in Carpet Yarn Manufacture (Six Certificates Topics)
5. Diploma in Carpet Technology (Six Certificates Topics)
6. Diploma in Apparel Yarn Manufacture (Six Certificates Topics)
7. Diploma in Carpet & Textile Designing (Six Certificates Topics)

Recognised by :-

Distance Education Council-AICTE-UGC joint committee, Govt. of India

Enrolled Candidate: 5 Study Centers: 3

#### C Industry Driven Training Programmes:

Skill upgradation programme under Integrated Skill Development Programme (ISDS) of Ministry of Textiles, Govt. of India.

Skill upgradation Programme under Comprehensive Handicrafts (Carpet) Cluster Development scheme (CHCCDS) Govt. of India.

Short Term Training programmes on Modular Employable Skills covering various approved / Need based on Modules related to Carpet & Textiles

Skill development cum orientation programme for Artisans: Weavers, Dyers, Instructors, Supervisors etc.

Workshop on Technical & Design Development. Institute can offer tailor made (Need based) training programme on:

Wool Technology: Raw material to finishing including marketing  
Carpet Technology: Introduction in Carpet Manufacturing to Advance Carpet Manufacturing.

- o Textile Technology: Fibre to Fabric
- o Special programme on usage of Natural Fibres & Natural Dyeing.

More than 2500 artisans have been created

More than 7000 artisans are being trained in coming 3 years

### Research & Development (R&D):

Institute undertakes sponsored R&D Project on any theme related to wool, carpet & textile on mutual acceptable understandings.

#### Technology Up gradation:

- i) Looms, tools & equipments .
- ii) New Carpet Backing System: Substitute to existing hazardous system has been developed and Patented.
- iii) New Cross Bar Horizontal Loom: Validated and accepted by industry due to reduction of drudgery and comfort to the weavers resulting improved quality and productivity. The design is patented.
- iv) Innovation of carpet backing system (Snehabha Carpet Backing System) which has been patented & registered for the trademark and covered under copyright. Industry has considered this innovation as a milestone for the handmade carpet industry and being commercialized.
- v) Concept of India Knot / Pile Formation Technology in handmade carpet manufacturing. This also has been considered another milestone for the sector and licensed. The technique & logo, both being patented.

#### Product Development:

Intervention of New materials like Natural Vegetable fibres, Eri Silk, Mod Acrylic, Art Silk and Modern Yarn, Introduction of Natural dyes.

#### Standardization:

Carpcost software developed by IICT under copyright meant for standardization for Cost & Quality through monitoring inputs & process



**2.3 If the project pertains to category 2.1 (c ), please indicate steps initiated for obtaining approval of Full Planning Commission:**

Not Applicable

**3. Justification for the project:**

**3.1 The justification for taking up/continuing the project or scheme may be provided:**

The need has been felt by University, Industry and management to make the institute viable and long-lasting as evident from documents annexed. The addition of M. Tech. in Carpet & Textile Management (CTM) to the existing field will increase the scope of service. The export turnover of the sectors together is not less than Rs. 25000 crores (3500 crores for Carpet, 4000 for Home Textiles & 17500 for rest). There is no such institute which can serve the need of the sectors in portfolios like HRD, DCD, R&D and TSI. Therefore, need for expansion of IICT is absolutely justified and could be the right decision on the part of Govt. of India.

**Proposed Strategy:**

The proposed strategy for implementation of different issues, which mentioned above includes initiation of

- Addition of relevant discipline M.Tech in Carpet & Textile Management (CTM)
- Extension of R&D to cover the need of the academic and industry.
- To act over Strength, Weakness, Opportunity & Threats (SWOT)
- To serve more sectors like Fashion and Apparel besides wool, home textiles including Handmade and Machine made Carpet & designing.

Therefore, their course content, curriculum, fee structure, student selection mechanism etc. for the relevant disciplines and strategy /proposal for other activities need to be in place as has been included as under:

### Strategy-wise action plan:

No.	Action	Remarks
1.	Addition of relevant discipline like M.Tech in Textile Management	To take up with University, AICTE and AIMA for initiation of affiliation and approval so that this course can be started w.e.f. 2017-18 academic year after expiry of the current phase-II of the project.
2.	Extension of R&D to cover the need of the academic and industry	To provide the service of Institute through academic and industrial R&D in need based manner. The other sector like Fashion and apparel industry also would be added as our stakeholders. To take up with the stakeholders to finalize the tentative indentified agenda. IICT will strengthen its R&D base in terms of enrollment for research scholars in all areas of textiles and management. Moreover, it will make its attempt to become a study centre for pre Ph.D works of the university.
3.	To act over Strength, Weakness, Opportunity & Threats (SWOT)	A cell will be created to generate data base through research and development in terms of market intelligence so that industry can become more pro-active in their decision related to trade.
4.	Incorporation of natural fibres like Jute linen, wool & silk aspects in the course curriculum and additional disciplines being installed	In the new syllabus necessary additions in subjects like: Fibre Science, Yarn Manufacturing, Advance Fabric Manufacturing, Internship, Project wherever scope existed so that future trainees/graduates /scholars more effective for the promotion of natural fibres.
5.	Synergy	IICT recognizes organizations like All India Carpet Manufacturing Association(AICMA), Carpet Export Promotion Council (CEPC) , other textile and related export promotions council including AEPC, Indian Woolen Mills Federation (IWMF) , Export Promotion Council for

No.	Action	Remarks
		Handicrafts (EPCH) and Wool & Woolen Export Promotion Council (WWEPC) ,Central Wool Development Board(CWDB), Ag-research (Newzealand), The Textile Institute Manchester and other potential institutes / organizations as valuable partners of IICT for having synergy in mutual interest of utilization of resources created and being created around all portfolios (HRD,R&D, DCD, TSI).
6.	Road map beyond 2016-17	The new SFC is proposed for next 5 years w.e.f. 2016-2017. Therefore the road map has been restricted to till 2020-2021 only. The year 2020-2021 shall be the 19 <sup>th</sup> functional year considering 2001-2002 as the 1 <sup>st</sup> functional year, As per target given by EFC dated 5.10.1998 the 1 <sup>st</sup> functional year should have been 2001-2002. Year wise and activity wise self sustainability plan for IICT,Bhadohi projected in the last EFC vide <b>annexure-V</b> of the documents provides target of 100% generation of revenue over recurring expenditure excluding pay and allowance ( copy enclosed). IICT is committed to maintain the similar self sustainability plan till 2021-29.

**Strategy & programme for extension of knowledge and skills benefiting the local people pursuing carpet trade:**

Strategy No.	Area	Strategies/ Remarks
1	Extension of knowledge & skill benefiting local people in particular but all concerned in general	<ul style="list-style-type: none"> <li>• IICT shall become a platform wherein all concerned who has enriched knowledge through Govt. assistance shall share with all relevant beneficiaries of the trade.</li> <li>• Net surfing guidance and facility on charge basis</li> <li>• Veteran personality from country and abroad shall be called to conduct programmes on issue of interest to carpet &amp; textile trade time to time.</li> </ul>
2	SWOT Analysis benefiting all concerned	Analysis & interpretation of data by IICT by means of collection of SWOT data through: <ol style="list-style-type: none"> <li>1. Visiting various websites.</li> <li>2. Contacting various embassies</li> <li>3. Contacting various councils of the world</li> <li>4. Visiting various countries.</li> </ol>
3	Incorporation of additional disciplines to make the Institute viable (continuation of 100% revenue over recurring expenditure other than pay and allowance and may all attempt to become self sustainable w.r.t. total recurring expenditure from year 2019-20 onwards)	To start M.Tech in Carpet & Textile Management (CTM) in addition to various modular courses which is likely to expend activities in the country in general and Bhadohi in particular. The module(s) to be integrated in course curriculum are: Fashion, Information Technology, Accounting, Business Management etc. as visualized by Secretary (Textile)
4	Mobile Service	In today's context, door-to-door service is well accepted/ appreciated, which has been the advice of His Excellency A. P. J. Abdul Kalam

		<p>President of India on the eve of Golden Jubilee resurgence of Handicrafts held at Vigyan Bhawan, dated 15.11.2002. Hon'ble President appreciated the role of IICT to serve such a rural sector and further advised Director IICT to become mobile. To implement above said strategy, procurement of required vehicles and mobile equipments is the pre-requisite.</p>
--	--	--



**His Excellency, President of India in discussion with Director, IICT during his visit to IICT gallery on the eve of Golden Jubilee of Handicrafts Resurgence in India on 15.11.2002 at Vigyan Bhavan, New Delhi in presence of other dignitaries.**

**3.2 The alternative that have been considered before firming up the design of the project may be stated. (this should also include alternate modes of project delivery, e.g. outsourcing PPP etc. that have been considered):**

Not Applicable

**3.3 Please state whether the project proposal has objectives and coverage which overlap with project / scheme being implemented by the same or another agency (Ministry/Department/ State government). In case of overlap, please**

**state why the project scheme need to be considered as a separate stand alone effort:**

There are no other scheme with overlapping objectives and coverage.

#### **4. Project Objectives and Targets:**

**4.1 The objective of the project may be mentioned. These objectives should flow from the project justification:**

The IICT after getting started in November 2001 could grow as desired to make it a Center-of-Excellence and endeavors made it to reach International Standard. However, achieving further excellence is in process.

The main objective of the scheme will be as under:

- Optimum utilization of resource
- Addition of relevant discipline M. Tech in Carpet & Textile Management (CTM)
- Extension of R&D to cover the need of the academic and industry.
- To act over Strength, Weakness, Opportunity & Threats (SWOT)
- To serve more sectors like Fashion and Apparel besides wool, home textiles including Handmade and Machine made Carpet & designing.

**4.2 The Expected date of project/ scheme completion may be stated. This should be realistic and supported with a chart indicating timeline for the important activities, with a critical path analysis, identifying the main constraints.**

#### **5. Project Design:**

**5.1 Briefly explain the project Design. This should include all components of the project:**

- Continuation of earlier project & introduction of M.Tech. in Carpet & Textile Management (CTM).
- Improvement / upgradation of existing infrastructure.
- Addition of infrastructure .
- Continued support of Pay & Allowances under Non-plan.

**5.2 In case the project or scheme is location specific, please state the basis for selection of such location:**

Expansion in the same location since no additional land is required. Additional land 20 acre provided to IICT can be better utilized.



- 5.3 If the project involves creation/modification structural and engineering assets or change in land use plans, disaster management concerns as brought out in O.M.No.37 (4)PF-II/2003 dated 19-6-2009 should be assessed. A self certification in this regard in the EFC Memo:**

Not applicable

- 5.4 In the case of beneficiary oriented project/ scheme, the mechanism for identification of the linkage of beneficiary identification with UID numbers may be indicated as advised in O.M. No. 1(3)/ PF- II/ 2001 dated 09.08.2010.**

Not applicable

- 5.5 Wherever possible, the mode of delivery should involve the panchayati Raj Institutions and Urban Local Bodies. Where this is intended, the preparedness and the ability of the panchayats for executing the project may be indicated. If exceptions are to be made, the reasons may be explained.**

Not applicable

- 5.6 In case the project involves land acquisition or environmental clearances, the specific requirements and the status in this regard may be indicated.**

Additional land ~20 Acre already provided by U.P. Government.

- 5.7 The legacy arrangements after the scheduled project duration may be mentioned. In case the project creates assets, arrangements for their maintenance and upkeep may be stated. (For example the project assets may be taken over and maintained by the State Government/ PRIs; ULBs).**

IICT is a Governmental Society. the Executive Committee with government direction to take all necessary steps.

- 5.8 Whether the guidelines of Bureau of Energy Efficiency and other related guidelines for energy efficient buildings etc. have been considered/ complied with.**

The constructional Consultant i.e. M/s Awas Evam Vikas Parisad, Varanasi is a approved U.P. Government Construction Agency. The TOR shall stipulate such condition that the guidelines of Bureau of energy Efficiency and other related guideline for energy efficient building etc. become mandatory.

- 5.9 Whether the project is secured against natural/ man-made disasters like floods, cyclones, earthquakes, tsunamis etc.**

All necessary steps will remain in built wherever applicable including appropriate insurance coverage.

## **6. Project/ Scheme cost**

6.1 Please provide the project cost estimate for its scheduled duration along with a breakup of year-wise, component-wise expenses segregated into non-recurring and recurring expenses. It may also be indicated whether land is needed, if so whether which agency is providing for it, and in case the cost of land is to be booked to the project, whether it has been included in the estimates:

### **Summary of Expenditure in Rs. lakhs from 2016-17 to 2020-21**

<b>Summary of activity</b>	<b>Non Recurring</b>	<b>Recurring</b>	<b>total</b>	<b>Remarks</b>
<b>Continuation of existing B.Tech (CTT with specialization), M.Tech. in Carpet &amp; Textile Management (CTM) and other portfolios</b>	<b>5423.36</b>	<b>1417.87</b>	<b>6841.23</b>	<ul style="list-style-type: none"><li>• Details of Non-recurring expenditure as per <b>Annexure-III</b></li><li>• Details of Recurring expenditure as per <b>Annexure-VI</b></li></ul>

**Annexure-III**

**A-Proposed Non-recurring Expenditure plan under EFC (Existing activity for the year 2016-17 to 2020-21)**

<b>S. NO.</b>	<b>Particulars of Items</b>	<b>Estimated Cost Rs. in Lakhs</b>
<b><u>Non-Recurring Expenditure at Pipris</u></b>		
<b>1.1.</b>	<b><u>Construction &amp; Development Works in IICT Campus at Pipris, Bhadohi Area~ 20 Acres.</u></b>	
1.1.1.	Area Development works including leveling , Internal Roads, Paths, Sewer, Water supply lines, Storms water drains, horticulture etc. @ Rs.600 per m <sup>2</sup> for ~45,000 m <sup>2</sup> out of total area.	270.00
1.1.2.	Completion/ re-enforcement, fencing work of boundary wall~1500 m@ Rs.12,000/- per running meter.	180.00
1.1.3.	Hostel Building for 120 inmates with Provision of 60 rooms , total 2200 m <sup>2</sup> area @ Rs. 18,000/- per m <sup>2</sup> & Furniture for 60 rooms @Rs. 25,000/- per room. With international level facilities also.	411.00
1.1.4.	Workshop/Lecturer Theater	
	• Workshop @ Rs. 11,250/- per m <sup>2</sup> for 2400 m <sup>2</sup> with provision of Store	270.00
	• Lecturer Theater Building @ Rs. 18,000/-per m <sup>2</sup> for area 1375 m <sup>2</sup>	247.50
	• Furniture & fixtures for Lecturer Theater Building @ Rs. 2,181/- per m <sup>2</sup> for 1375 m <sup>2</sup>	30.00
1.1.5.	Administrative Building	
	• Building @ Rs. 18,000/- per m <sup>2</sup> for area 2400 m <sup>2</sup>	432.00
	• Furniture & Fixture @ Rs. 2,500/- per m <sup>2</sup> for 2400 m <sup>2</sup>	60.00
1.1.6.	Staff Accommodation building @ 18,000/- per m <sup>2</sup> for 2500 m <sup>2</sup>	450.00
1.1.7.	O.H.T., Pump room, Generators etc.	100.00
1.1.8.	Guest House/Faculty House/Alumni block	
	• Building Rs. 18,000/- per m <sup>2</sup> for 1200 m <sup>2</sup>	216.00
	• Furnishing @ 2500/- per m <sup>2</sup> for 1200 m <sup>2</sup>	30.00
1.1.9.	Play ground & amenities for students –developing ~1200 m <sup>2</sup> area with amities @Rs.10,000/- per m <sup>2</sup> ( Part activity may be undertaken in Chauri Road Campus)	120.00
<b>Sub Total (A)</b>		<b>2816.50</b>
<b>1.2.</b>	<b><u>Construction &amp; Development works in IICT Campus at Chauri Road, Bhadohi</u></b>	
1.2.1.	Vertical Extension by one floor in Existing Director's Bungalow 269.28 m <sup>2</sup> & Staff Quarter ( Existing 2 floor buildings 2 Nos., 139.77 m <sup>2</sup> and 219.54 m <sup>2</sup> ) Total area 628.59 m <sup>2</sup> @ Rs. 18,000/- per m <sup>2</sup>	113.15
1.2.2.	Vertical Extension by one floor in Existing Academic block to accommodate library & Class Room (s)	
	• Building 1200 m <sup>2</sup> @ Rs. 18000.00 per m <sup>2</sup> .	216.00
	• Furniture & Fixture@ Rs. 2500 per m <sup>2</sup> for 1200 m <sup>2</sup>	30.00
1.2.3.	Modification of Conference Hall –area 464.15 m <sup>2</sup>	
	• Including furniture & fixtures @ Rs.12500/- m <sup>2</sup>	58.02
	• Auditorium on existing Conference Hall–area 464.15 m <sup>2</sup> @Rs.25,000/- per m <sup>2</sup>	116.04

	1.2.4.	Extension of Open Air Theater area ~450 m <sup>2</sup> @Rs. 8,500/- per m <sup>2</sup>	38.25
		<b>Sub Total (B)</b>	<b>571.46</b>
		<b>Total (A+B)</b>	<b>3387.96</b>
<b>1.3.</b>	<b>Electrical Works @ 8% of above(A+B) -C</b>		<b>271.04</b>
		<b>Sub Total (A+B+C)</b>	<b>3659.00</b>
<b>1.4.</b>	<b>Consultancy fee@ 12.5 % of Sub Total (A+B+C) - D</b>		<b>457.38</b>
		<b>Sub Total ( A+B+C+D)</b>	<b>4116.38</b>
<b>1.5.</b>	<b>Contingencies</b>		<b>55.82</b>
		<b>Total (A+B+C+D+E)</b>	<b>4172.20</b>
<b>Variation in quantities within estimated cost may be considered</b>			
<b>2.1</b>	<b>Additional Works to be undertaken as per direction of Higher authorities &amp; emerging needs</b>		
	2.1.1.	Enhancement in Teaching Infrastructure/classroom activities - Overhead projectors in 4 classrooms (~ Rs.85,000/- X 4 Nos.), Electronics Display boards (~Rs. 75,000/-X 4) etc.	<b>10.00</b>
	2.1.2.	Swachch Bharat Mission –heavy duty machine/equipments of sweeping -2 no.@ Rs.3.5 lacs, Miscellaneous sweeping items like hand trolley, litter bins etc.	<b>10.00</b>
^^^	2.1.3.	Greening -Development of Green Belt	<b>5.00</b>
	2.1.4.	Rain water harvesting covering area of terrace in buildings and open floor area	<b>50.00</b>
	2.1.5.	Solar Energy generation ~ 125 KW	<b>296.00</b>
	2.1.6.	Compost pits – 2units	<b>2.46</b>
	2.1.7.	Effluent Water Treatment Plant	<b>10.00</b>
	2.1.8.	Community centre (Dispensary/Yoga/Recreation etc.)	<b>15.00</b>
	2.1.9.	Independent vehicle for Director, IICT	<b>12.00</b>
	2.1.10	Ambulance for students	<b>8.00</b>
	2.1.11	Books for Library	<b>30.00</b>
		<b>Sub Total (F)</b>	<b>448.46</b>
<b>3.1</b>	<b>Plant &amp; Equipments ( details as per annexure- VI)</b>		<b>802.70</b>
		<b>Grand Total</b>	<b>5423.36</b>

Note: Provision exist for construction of proper ramp(s), to take care of movement of handicapped person in the building(s).

**B-Proposed Recurring Expenditure Plan under EFC (Existing activity for year 2016-17 to 2020-21) Rs. in lakh Annexure-VI**

	<b>B-Recurring Expenditure</b>	<b>Total</b>	<b>2016-17</b>	<b>2017-18</b>	<b>2018-19</b>	<b>2019-20</b>	<b>2020-21</b>
<b>R-1</b>	<b>Pay &amp; Allowances</b>						
	vances for additional 26 posts.	<b>747.87</b>	100.50	120.60	144.72	173.66	208.39
<b>OR</b>	<b>Other than Pay &amp; Allowances</b>						
<b>R-2</b>	TA/DA (including foreign travel)	<b>55.00</b>	9.00	10.00	11.00	12.00	13.00
<b>R-3</b>	<b>Electricity Expenses</b>						
<b>R-4</b>	1) Electricity from UPPCL	<b>30.00</b>	4.00	5.00	6.00	7.00	8.00
	2) Diesel for Generator	<b>85.00</b>	14.00	16.00	18.00	18.00	19.00
<b>R-5</b>	Raw Materials & Cosumables for Lab	<b>25.00</b>	3.00	4.00	5.00	6.00	7.00
<b>R-6</b>	Repair & Maintenance	<b>50.00</b>	8.00	9.00	10.00	11.00	12.00
<b>R-7</b>	Petrol & Diesel for Vehicle etc.	<b>7.50</b>	1.50	1.50	1.50	1.50	1.50
<b>R-8</b>	Printing & Stationary	<b>30.00</b>	4.00	5.00	6.00	7.00	8.00
<b>R-9</b>	Advertisement	<b>25.00</b>	3.00	4.00	5.00	6.00	7.00
<b>R-10</b>	Workshop & Seminars	<b>7.50</b>	1.50	1.50	1.50	1.50	1.50
<b>R-11</b>	Staff Training & Exhibition etc.	<b>10.00</b>	2.00	2.00	2.00	2.00	2.00
<b>R-12</b>	Membership Fees	<b>10.00</b>	2.00	2.00	2.00	2.00	2.00
<b>R-13</b>	IICT-Industry interface for (involving faculty as mentor & students as resource) a technical process, product development support including E.D.P.	<b>71.00</b>	10.00	12.00	14.00	16.00	19.00
<b>R-14</b>	Internationalization (Admission & interface: visits/collaboration)	<b>95.00</b>	15.00	17.00	19.00	21.00	23.00
<b>R-15</b>	Market intelligence cell	<b>54.00</b>	8.00	10.00	11.00	12.00	13.00
<b>R-16</b>	Journals (National & International)	<b>20.00</b>	4.00	4.00	4.00	4.00	4.00
<b>R-17</b>	Professional Fee	<b>5.00</b>	1.00	1.00	1.00	1.00	1.00
<b>R-18</b>	Auditors Fees	<b>5.00</b>	1.00	1.00	1.00	1.00	1.00
<b>R-19</b>	AMC for Plant & Equipments, Outreach Activity & Other Contingency (unforeseen expenditure)	<b>85.00</b>	17.00	17.00	17.00	17.00	17.00
	<b>Sub total other than Pay &amp; Allowances</b>	<b>670.00</b>	<b>108.00</b>	<b>122.00</b>	<b>135.00</b>	<b>146.00</b>	<b>159.00</b>
	<b>Grand Total</b>	<b>1417.87</b>	<b>208.50</b>	<b>242.60</b>	<b>279.72</b>	<b>319.66</b>	<b>367.39</b>

**Note: Pay & Allowances for regular sanctioned post is covered under Non Plan and provision for additional 26 posts approved by EFC Rs.747.87Lakhs is proposed to be added under Non Plan.**

**BREAK UP OF TARGET REVENUE (HRD, DCD, R&D, TSI AND ADDITIONAL) CUM SELF SUSTAINABILITY PLAN**  
**Annexure-V**

	Portfolios/ Year :New phase (functional)	All figures are in Rs. (lakhs)					
		Total	2016-17	2017-18	2018-19	2019-20	2020-21
<b>1</b>	<b>HRD</b>						
	* B. Tech.	550.00	110.00	110.00	110.00	110.00	110.00
	*M.Tech.	87.60	00.00	10.50	17.90	25.90	33.30
	* Other Programmes	75.00	15.00	15.00	15.00	15.00	15.00
		<b>712.60</b>	<b>125.00</b>	<b>135.50</b>	<b>142.90</b>	<b>150.90</b>	<b>158.30</b>
<b>2</b>	<b>DCD</b>						
	* Creation, CAD Rental, Color Xerox/ Other, * Sampling etc	28.00	04.00	5.00	6.00	6.00	7.00
		<b>28.00</b>	<b>04.00</b>	<b>5.00</b>	<b>6.00</b>	<b>6.00</b>	<b>7.00</b>
<b>3</b>	<b>R&amp;D</b>						
	* Product	40.00	5.00	6.00	8.00	10.00	11.00
	* Project consultancy/ overhead @20%	38.00	5.00	7.00	8.00	9.00	9.00
	* Technology Transfer etc.	38.00	5.00	7.00	8.00	9.00	9.00
		<b>116.00</b>	<b>15.00</b>	<b>20.00</b>	<b>24.00</b>	<b>28.00</b>	<b>29.00</b>
<b>4</b>	<b>TSI</b>						
	* Sample Testing	25	3.00	4.00	5.00	6.00	7.00
	* Certification of Products	10	2.00	2.00	2.00	2.00	2.00
	* Others (Home Textile Lab, Advance Carpet Lab, Spinning Lab, Weaving Lab, Engg. Lab)	18	2.00	2.50	4.00	4.50	5.00
		<b>53.00</b>	<b>7.00</b>	<b>8.50</b>	<b>11.00</b>	<b>12.50</b>	<b>14.00</b>
<b>5</b>	<b>Additional</b>	9.5	1.50	2.00	2.00	2.00	2.00
	<b>GRAND TOTAL (1 to 5)</b>	<b>919.10</b>	<b>152.5</b>	<b>171.00</b>	<b>185.90</b>	<b>199.40</b>	<b>210.30</b>
	<b>Recurring expenditure</b>	<b>670.00</b>	<b>108.00</b>	<b>122.00</b>	<b>135.00</b>	<b>146.00</b>	<b>159.00</b>

**SELF SUSTAINABILITY PLAN:**

	Total	2016-17	2017-18	2018-19	2019-20	2020-21
<b>Revenue Generation</b>	919.10	152.5	171.00	185.90	199.40	210.30
<b>RE (excluding pay &amp; Allowances (REC))</b>	670.00	108.00	122.00	135.00	146.00	159.00
<b>% Rev/Rec</b>	<b>137.18</b>	<b>141.20</b>	<b>140.16</b>	<b>137.70</b>	<b>136.58</b>	<b>132.26</b>

**Students Enrollment Statistics:**

Year	Undergraduate & Post Graduate				Total
	B.Tech. (Existing CTT)	M.Tech. (CTM)	Ph.D	IDLP	
2016-17	276	--	5	50	331
2017-18	276	20	10	100	406
2018-19	276	40	10	100	426
2019-20	276	40	15	100	431
2020-21	276	40	20	100	436
<b>Total</b>	<b>1380</b>	<b>140</b>	<b>60</b>	<b>450</b>	<b>2030</b>

## List of Equipments:

Sl. No.	Name of the Lab	Name of the Equipments*	Number of Unit	Estimated Price (Rs)	Justification
1	Advance Carpet and Textile design Lab	1) Dobby design software 2) Jacquard design software 3) Design Computer System(25) 4) HP Colour plotter 24" (1) 5) HP Colour plotter 36" (1) 6) Nedgraphics software new(5) 7) Chromo tone shades 2013 (1) 8) Small size computer table(25) 9) Projector with stand screen (1) 10) Round chair (25) 11) LCD monitor 48" (1) 12) Split AC (1) 13) ARS colour shade wool (1600) (1) 14) ARS silk colour shade (1) 15) Almirah (3) 16) Printer (1) 17) Color printer (1) 18) HP Scanner (5) 19) Designer digitizer pen (10) 20) Studio designer table (2) 21) Chair (2) 22) Tracing table (2) 23) 5KVA UPS (2) 24) Pin board (5) 25) Classroom board (1) 26) Camera (1) 27) Internet broadband (1) 28) Manual design dev. Lab 29) Computer accessories 30) Manual design dev. Table (25) 31) Chair (50)	1 1 25 1 1 5 1 25 1 25 1 1 1 1 1 1 3 1 1 1 1 10 2 2 2 2 2 2 2 5 1 1 1 1 -- 25 50	80.00	To meet the academic and industrial requirement
2	Advance Carpet & Fabric Manufacturing Lab	1) Beam warping machine 2) Sizing machine 3) Sectional warping machine 4) Shuttle less loom with electronic doobby 5) Electronic jacquard fitted needle loom 6) Rug weaving machine		80.00	To meet the academic and industrial requirement
3	Home Textile Lab	1) Single needle lock stich (25) 2) Progamable lock stich (2) 3) Sewing machine with different feed M/c (5) 4) Chain stich (2) 5) Over lock (2) 6) Interloc (2) 7) Button Hole (1) 8) Button Attach (1) 9) Bartack (2) 10) Double Needle chain stich (1) 11) Folders and works aids (2) 12) Die cutting (1) 13) Straight knife (2)	25 2 5 2 2 2 1 1 2 1 1 1 1 2		To meet the academic and industrial requirement



		14) Band knife (1) 15) Vacuum steam iron (1) 16) Fusing M/c (1) 17) Pattern tables (5) 18) Cutting Table (10) 19) Feed of the arm m/c (1) 20) Profile sewing M/c (1) 21) Automatic welt pocket attach(1) 22) CNC Cutter (1) 23) Pin table (1) 24) Auto Spreader (1) 25) Form finisher (1) 26) Pattern making software (5) 27) Digitizer (1) 28) Plotter (1) 29) Dummies (male20+20 female) 30) Computers (10) 31) Laptop (5) 32) Air conditioner (2) 33) Embroidery machines (10) 34) Sewing accessories (30) 35) Embroidery accessories (30) 36) LCD projector (2)	1 1 1 5 10 1 1 1 1 1 1 1 5 1 1 1 40 10 5 2 10 30 30 2	83.70	
4	Audio Visual Lab	1. LCD Projectors 2. Computers 3. LAP TOP 4. Headphone 5. Display Screen, Furniture & Fixtures for 60 capacity. 6. Audio and video recordings and educational software 7. Video conferencing system 8. Scanners 9. Language Library 10. Software for video editing and color visual aid system 11. LCD Computer System (10 Nos) 12. High resolution video camera	2 5 2 10 -- -- 1 2 -- 1 10 1	40.00	Essential to teach B.Tech . (CTT) & M.Tech. (CTM) students through virtual classroom and electronic study material like CD etc. for latest development and machine catalogues
5	Advance Textile Testing Lab	1. Tog meter 2. Sonometer 3. Yarn Bulkometer 4. Fabric softness tester 5. Fabric TIV tester 6. Alambata tester 7. Shirley friction tester 8. MVTR apparatus tester 9. Wicking tester	1 1 2 1 1 1 1 1 1	80.00	Requirement for industrial consultancy, testing and R&D activity.
6	Advance Textile Chemistry Lab	1) Lab dryer-1 2) Printing table-4 3) Screen making m/c-1 4) Vertical steamer lab model-1 5) Universal steamer -1 6) Two roller vertical padder-1 7) Two roller laboratory calendar-1 8) Jigger lab model -1 9) Beaker dyeing m/c lab model-2 10) Jet dyeing m/c lab model-1	1 4 1 1 1 1 1 1 2 1	54.00	Requirement for industrial consultancy, testing and R&D activity.

		11) Pad steam range lab model-1 12) Two arm dyeing for silk hank-1 13) Colour matching cabinet-2 14) Labcoater -1 15) High Temperature Laboratory Steamer-1 16) Auto Colour Dispenser Lab Model -1	1 1 2 1 1 1		
7	<b><u>Computer &amp; IT Lab</u></b>	1. Computer & Software 2. Broadband 3. V-sat/ wifi system 4. Laptops 5. Lejar Printer 6. Scanner 7. Air Conditioner 8. LED Projector 9. Lab Renovation with insulated floor covering etc. and UPS System for 30 students capacity	30 1 1 30 1 2 4 2 1	50.00	Computer & internet facility to students & staffs
8	<b><u>Library:</u></b>	1) CC TV 2) Audio & Visual 3) Furniture Racks 4) Computer terminal 5) LAP Top 6) Library server 7) Microfish & Chip Reader 8) Photocopy Machine 9) UPS System 10) Air conditioner 11) Library software	5 1 30 7 1 1 1 1 1 2 1	40.00	Facilitate up-gradation of library and modern learning process
9	English & Foreign language lab	Includes software, Conference System, Projectors & Display Systems And furnitures & Fixtures	20.00	20.00	To take up essential language courses for the students soft skill development
10	Fashion Lab			50.00	
11	Soft Skill Lab	Accounting, Finance, Entrepreneurship Development Programme etc.		15.00	
12	Advanced CAD/CAM lab	To upgrade the institute with appropriate technology and software to take care of emerging need in all the fields of carpet and textile technology		205.00	
13	Advance spinning and Recco and Nonwoven 500 mm Solar Charkha etc.				
14	Upgradation of existing workshop (Spinning, dying, weaving etc.)				
15	Exclusive PG Lab		Research Equipment		
<b>Total Rs.</b>				<b>802.70</b>	

\*The name and type of equipment(s) may be added or deleted at the time of execution depending on need at that time, however within estimated cost.

**6.2 Estimated expenditure on project administration (including expenses on consultants, etc.) May be separately indicated.**

Expenditure on project administration (including expenses on consultant) is Rs.457.38Lakhs (Details available in Non-recurring expenditure as per Annexure-III)

**6.3 The basis of these cost estimates along with the reference dates for normative costing may be provided. The firmness of the estimate may be indicated along with the cost components that can vary, the factors that could cause the variation and the extent of the expected variation.**

Estimate received as annexure-III to covering letter of the e-mail from LIC, Kanpur, the consultant of IICT approved by Government of India further added to attain the objective of Swachh Bharat Mission, Greening, Rain Water Harvesting, Solar Energy Generation as directed higher authorities & emerging needs will be vetted/taken care of, by the construction consultant M/s Awas Evam Vikas Parishad, Varanasi

**6.4 In case the project/ scheme involves payout of subsidy, the year wise expected outgo, up to the last year of payout, may be indicated.**

Not applicable

**6.5 In case the project/ scheme intends to create capital assets, employ specialized manpower or involves other activities that necessitate a Recurring Cost of Capital Expenditure (RCCE) (e.g., maintenance and upkeep costs of assets, salary costs of manpower, etc.) over the lifetime of the asset, such expenditures, on an annual basis, may be indicated in the project proposal.**

Yes it is mentioned in Annexure-II (R-6)

**6.6 It may also be stated whether the agency which would be assigned this legacy responsibility has been consulted and has agreed to bear the continuing recurring expenditure. (e.g., the State governments may need to incur the maintenance and upkeep costs of assets created under plan schemes.**

Yes IICT is committed to maintain recurring expenditure other than Pay & Allowances 2021-22 onwards.

**6.7 The cost towards salary/ fees/ emoluments of the project human resources as being proposed should be indicated (procedure for seeking approval of the human resource requirements is however detailed at para-7 below).**

Cost towards Salary/Fees/Emoluments have been covered under Non plan.

**6.8 The component of the costs mentioned at 6.1-6.7, that will be shared by the state governments may be indicated.**

State Government has contributed in providing land approximately ~20 acres free of cost. IICT will continue to seek fund for Non-recurring and will to continue to get fund for Pay & Allowances under Non-plan as approved.

- 6.9 **In the event of fund transfer being made to State Govt. / local bodies or other organizations. "grants for creation of capital assets" may be indicated separately.**

There is no share from the State Government.

## **7 Project Human Resources**

- 7.1 **Please indicate whether the nodal officer directly in charge of the project has been identified. Details about his status, past experience in executing similar projects and balance tenure left for steering the project may also be mentioned.**

Director, IICT is the Nodal Officer under the guidance of O/o the Development Commissioner (Handicrafts) Ministry of Textiles, Government of India.

- 7.2 **In case posts (permanent or temporary) are intended to be created, such proposal may be sent on file to personnel Division of Department of Expenditure separately. Such proposals may be sent only after the overall project proposal is recommended by the appropriate appraisal body (SFC, EFC, etc.).**

### **Manpower planning**

Sanctioned v/s. Filled Posts status as on date

SI No.	Designation	Pay Scale	Mode Recruitment	No. of Sanctioned post	Status	
					Filled	Vacant
1.	Director	37400-67000 (AGP10000+Spl allowance 3000)	Direct	1	1	-
2.	Professor	37400-67000 (AGP 10000)	Direct	3	1	2
3.	Associate Professor	37400-67000 (AGP 9000)	Direct	5	3	2
4.	Assistant Professor	15600-39100 (AGP 6000)	Direct	7	7	-
5.	Librarian	15600-39100 (GP 6000)	Direct	1	1	-
	<b>Sub Total (A)</b>			<b>17</b>	<b>13</b>	<b>4</b>

### **Non Teaching Staff (Supporting Staff):**

SI. No.	Designation	Pay Scale		No. of Sanctioned post	Status	
					Filled	Vacant
1.	Registrar	15600-39100 (GP 6600)	Direct	1	-	1
2.	ASO	15600-39100 (GP 5400)	Direct	1	1	-
3.	AO	15600-39100 (GP 5400)	Direct	1	1	-
4.	Phy. Lab I/C	9300-34800 (GP 4600)	Direct	1	1	-
5.	Chem Lab I/C	9300-34800 (GP 4600)	Direct	1	1	-
6.	Design Lab I/C	9300-34800 (GP 4600)	Direct	1	1	-
7.	Computer Lab I/c	9300-34800 (GP 4600)	Direct	1	-	1
8.	Workshop I/C	9300-34800 (GP 4600)	Direct	1	1	-

Sl. No.	Designation	Pay Scale		No. of Sanctioned post	Status	
					Filled	Vacant
9.	Lab Asstt.	9300-34800 (GP 4200)	Redeployment for 1No.	9	4	5
10.	Office Asstt.	9300-34800 (GP 4200)	Redeployment	4	-	4
11.	Admn. Asstt.	9300-34800 (GP 4200)	Direct	1	1	-
12.	Computer Lab Asstt.	9300-34800 (GP 4200)	Direct	1	1	-
13.	Library Asstt.	5200-20200 (GP )2400	Direct	1	1	-
	<b>Sub Total (B)</b>			<b>24</b>	<b>13</b>	<b>11</b>

**Non Teaching staff (Skilled & Semi Skilled etc.):**

Sl. No.	Designation	Pay Scale		No. of Sanctioned post	Status	
					Filled	Vacant
1.	Operator	5200-20200 (GP1900)	Direct	1	-	1
2.	Fitter	5200-20200 (GP1900)	Direct	2	-	2
3.	Cpt. I/C.	5200-20200 (GP2400)	Direct	1	-	1
4.	Dyeing Operator	5200-20200 (GP1900)	Direct	1	-	1
5.	Finishing Operator	5200-20200 (GP1900)	Direct	1	-	1
6.	Skilled Worker	5200-20200 (GP1800)	Direct	2	-	2
7.	Semi Skilled	5200-20200 (GP1800)	Direct	3	-	3
8.	LDC	5200-20200 (GP1900)	Redeployment	2	-	2
9.	Unskilled	5200-20200 (GP1800)	Direct	1	1	-
10.	Ele. Tech.	5200-20200 (GP1900)	Direct	1	1	-
11.	Driver	5200-20200 (GP1900)	Direct	1	1	-
	<b>Sub Total (C)</b>			<b>16</b>	<b>3</b>	<b>13</b>
	<b>Grand Total (A+B+C)</b>			<b>57</b>	<b>29</b>	<b>28</b>

Note:

\* Dr. KK Goswami, Director, IICT himself is acting as one of the professor also as per decision of Executive Committee of IICT.

\*\* To honour the decision taken by EFC Meeting dated 5<sup>th</sup> October 1998, IICT is exploring possibility of redeploying staff of DC(HC). As on date services of O/o. DC(HC) posted 10 staffs of different category are availed by IICT based on their capacity and hiring of services on contract basis through agency is also availed wherever possible. By doing this IICT is in a position to achieve the given target of Revenue Generation over Recurring Expenditure.

### **ADDITIONAL MANPOWER REQUIRED**

**Reference: M/Fin(Exp) I.D. No.1485/E.coord.I/2001 dated 27-01-2001.**

EFC vide minutes of meeting dated 02-02-2007 resolved in point No.6 (clause no.4) as under:

*“ For creation of proposed 26 posts a proposal may be sent to JS (Pers). However institute should also introduce the system of engaging guest faculty”.*

**Sanction for 9 New posts of Faculty as under:**

- Professor ..... 1 Posts
- Associate Professor.... 3 Posts
- Asst Professors..... 5 Posts

**Sanction for 17 New posts of Non Teaching as under:**

- Asstt. Librarian 01 Post (PB 3 PB3 15600-39100 with GP 5400)
- PS to Director 01 Post PB2 9300—34800 with GP 4800
- Asstt Lab Manager 04 Post PB2 9300—34800 with GP 4600
- Office Superintendent 01 Post PB2 9300—34800 with GP 4800
- Office Assistant... 03 Post PB2 9300—34800 with GP 4200
- Technical Asstt – ..... 06 Posts PB2 9300—34800 with GP 4200
- Library Assistant... 01 Post PB2 9300—34800 with GP 4200

**7.3 In case outsourcing of services or hiring of consultants is intended, brief details of the same may be indicated. It may also be certified that the relevant GFR provisions will be followed which engaging the agency/ consultant.**

Details available in point No.7.2 (additional manpower required)

**7.4 In case additional manpower requirement, please indicate the phased requirement over the project timeline (i.e. year-wise break-up of the manpower requirement)**

**Faculty requirement Phase wise:**

Year	Total enrollment of student	Professor	Associate Professor	Asstt. Professor	Total*	Remarks
2016-17	281	2	4	13	19	19+1
2017-18	306	2	4	14	20	
2018-19	326	2	5	15	22	20+2
2019-20	331	2	5	15	22	
2020-21	336	2	5	15	22	

\*1:15, faculty: students: and 1:2:6: Professor: Associate Professor: Assistant Professor

**Year wise additional requirement cadre wise faculty:**

Year	Professor			Associate Professor			Asst. Professor			Total		
	Required	Existing Sanctioned	Additional requirement	Required	Existing Sanctioned	Additional requirement	Required	Existing Sanctioned	Additional requirement	Required	Existing Sanctioned	Additional requirement
2017-18	2	3	0	4	5	0	13	7	6	20	15	5
2018-19	2	3	0	4	5	0	15	7	8	22		7
2019-20	2	3	0	5	5	0	15	7	8	22		7
2020-21	2	3	0	5	5	0	15	7	8	22		7

\*1:15, faculty: students: and 1:2:6: Professor: Associate Professor: Assistant Professor

- As decided by EFC meeting dated 5<sup>th</sup> October, 1998, IICT shall continue saving significant expenditure by hiring of services on contract basis wherever possible against sanctioned post.
- IICT shall follow ACP as per AICTE rules for Teaching Staff and Govt. of India rules for other staffs in general.
- Those who have got desired qualification may be promoted in their respective cadre as proposed above through institute RR & DPC. All attempt shall be taken to utilize staff in pay scale equivalent to Assistant Professor and faculty also.
- Considering additional manpower required for Phase-II expansion has not yet been availed, the proposal of IICT to manage its activities with further expansion seeking only 20 additional posts may be considered as commitment for effective utilization of human potential. Moreover the effect outsourcing has been reflected in the requirement.



## **8. Project financing:**

**8.1 The source of financing for the project may be indicated. In case of project already included in the FYP, the specific earmarking may be mentioned. In case of any deviations from this quantum, the sponsoring agency may indicate how the gap will be addressed.**

Through O/o Development Commissioner (HC), Ministry of Textiles, Government of India.

**8.2 The availability of funds in the budget of the present year and the requirements projected may be mentioned. In case of any deviations, please indicate how the gap will be addressed.**

The fund available in SFC of Phase-II amounting to Rs.494.94Lakhs. The estimated expenditure for F.Y. 2015-16 already have been submitted to O/o Development Commissioner (HC) vide letter No.1/DMC/DIR/GEN/10/IICT dt. 27-01-2015. The above mentioned said amount yet to be released by O/o Development Commissioner (HC) to Indian Institute of Carpet Technology (IICT).

**8.3 If external sources are intended, the sponsoring agency may indicate whether such funds have been tied up. In case firm commitment is not available, alternate plans for arranging funds may be indicated.**

Not applicable

**8.4 Whether the funding requirements have been fully tied up with planning Commission may be indicated.**

SFC/EFC involves Secretary (T) & Plan through O/o Development Commissioner (Handicrafts), Ministry of Textiles, Government of India.

## 9. Project viability:

9.1 In case of projects which have identified stream of financial returns, the financial internal rate of return may be calculated. The hurdle rate is considered at 12%.

### FINANCIAL ANALYSIS

Analysis of phase I & II (EFC & SFC) :

Students Enrolled (ES):628,

Revenue Generated (RG):Rs 1779.19 lakh and Recurring expenditure (RE): Rs.3147lakhs

- Rs.163.92 yet to be released by O/o DC(HC) to IICT.

Fund allocated vide RCEIII (Rs. In Lakhs)			Over All	Target/ Bench mark	
Fund allocated/ utilized till	1998-99(1) ...,2015-2016(16)				
Functional Year:36months from 5.10.1998	Nov.2001 onwards i.e. 2001-02				
SFC/EFC	I	II		-EFC Target.	
NON RECURRING	1320.00	1143	2463		
RECURRING(RE)	484.00	1356	1840		
Total	1804.00	2499*	4303		
No. of years involved	9	10	19		
Amount released to IICT (Avg. per annum)	200.44	249.90	226.47		
Amount released as % to yearly turnover (@ Rs. 3000 crore & 7000 crore for SFC I & II respectively)	0.067	0.036	0.046		
% RG/RE (1779.19/3147x100)	-	-	56.54		50.00 <sup>1</sup>
(a) RE/ES (RsLakh) (3147/628)	-	-	5.01		NA
(b) RG/ES (Rs Lakh) (1779.19/628)	-	-	2.83		NA
(a)-(b):Nett RE effect (5.01-2.83)	-	-	2.18	NA	

**Analysis of investment made in iict in trade turnover context**

LEVEL OF TURNOVER IN EXPORT HOUSE	INDIRECT INVESTMENT	
	Rs. In lakhs	Rs. In thousands
Rs. 10 Lakhs	0.0046	0.46
Rs. 20 Lakhs	0.0092	0.92
Rs. 50 Lakhs	0.0230	2.30
Rs. 100 Lakhs	0.0460	4.60
Rs. 200 Lakhs	0.092	9.20
Rs. 500 Lakhs	0.230	23.00
Rs. 1000 Lakhs	0.460	46.00
Rs. 2000 Lakhs	0.920	92.00

**INTERPRETATION OF THE ABOVE ANALYSIS**

- Investment made so far in IICT clearly reveals that individual exporter even if reimbursed the amount equivalent to turnover cannot create at all any support system of its own to sustain in the global business environment.
- Output given by IICT so far clearly depicts commendable contribution to the industry and IICT deserves to be appreciated and acknowledged its contribution to the carpet, home textile and wool industry including designing sector. As per statistics IICT produced around 30000 outputs in last 14 years averaging around 2609 per year which works out to ~TEN (10) outputs every day on accumulation of activities in established portfolios: HRD, DCD, R&D, TSI .The average value of output even if kept at a reasonably lower level i.e. Rs. 0.50 lakh, IICT has given impact to the industry in general and society as whole to the level of ~1305 lakhs/annum. The impact in turn of pay back as a whole is 3 months only for every year at the current rate. (Average investment: Rs.307.36 lakhs /annum as on date vis-à-vis impact of 1305 lakhs).
- The future plan of IICT to add more disciplines and activities as well as doorstep service may be considered to be feasible.
- Considering additional activity, the exporters cum manufacturers covered under EPCH and IWMF/ WVEPC and Textile related export promotion council or manufacturing associations including AEPC will also get benefit.
- Keeping the investment @0.04%, (<0.046) and covering apparel sector also (assuming investment of 10 crore over 25000 crore total turnover)

the expansion plan supporting IICT through new phase (SFCIII) cumulative investment to go upto around Rs. 68.41 crore, which can sustain the Institute till 2020-21. The impact of investment and sustainability plan (partly self-sufficient with respect to recurring expenditure) as projected in the roadmap is enclosed herewith ( **Annexed-VI** )for consideration of competent authorities .The document depicts a healthy picture which is expected to be acceptable by all concerned to sanction this budget estimate.

**Impact made to the sector through Phase I & II: EFC & SFC:**

The institute has been able to serve the sector through following actions:

- Taking decisions through meetings of Executive Committee
- Laying of 12 Annual Reports in both the houses of parliament (Copy enclosed)

- The institute has been able to be a pro-industry through formation of Kaleen Bandhu comprises of members from the industry who meet and discuss time to time to take up agenda of mutual interest.
- The institute has been able to come out with its Directories. 3 such directories has been circulated to all concerned with focus on strengthening of industry-institute interface. (Copies of are enclosed)
- The institute has been able to develop academic community/ culture as evident from various publications which includes publication entitled ‘Advances in Carpet Manufacture published by M/S Woodhead Publishing, UK.
- Commercialization of R&D:
- The institute has started guiding Research scholars those who are pursuing for their doctorate degree pertain to the field of wool/ carpet/ textiles.

**9.2 In case of projects where financial returns are not readily quantifiable (typically social development projects), the economic rate of return may be estimated.**

#### **Analysis of SFC III proposed**

#### **Analysis of Investment ( Rs. in lakhs)**

Total investment for 5 Years (2016-17 to 2020-21)	5423.36
Per Year Investment at current rate (5423/5)	1084.67
<i>Turnover (Carpet +Home Textiles + Wool &amp; Woolens) at current rate in approximation</i>	20000
% to Sector's Turnover	0.054

#### **Need for Phase- III : SFC /EFC**

In phase III for continuation of existing activities with existing sanctioned strength of faculty and staff investment has been kept limited to Rs. 68.41 crore only considering the need for continuation. The viability of continuation of existing activities has been reinforced by conducting training programme under ISDS and CHCDS.

#### **10. Project implementation and monitoring:**

**10.1 The administrative structure for implementing the project may be stated. In case new structures/ entities etc. is by and large to be avoided. In case new structure are intended to be created for administering the scheme. The details of such structures and specific justification for the same may be provided. Such new structure should be processed only if it has been established after due analysis, that existing structures cannot be levered for the proposed / additional work.**

#### **Need for Expansion:**

The need has been felt by University, Industry and management to make the institute viable and long-lasting as evident from documents annexed. The addition of M.Tech in Carpet & Textile

Management (CTM) to the existing field will increase the scope of service. The export turnover of the sectors together is not less than Rs. 25000 crores (3500 crores for Carpet, 4000 for Home Textiles & 17500 for rest). There is no such institute which can serve the need of the sectors in portfolios like HRD, DCD, R&D and TSI. Therefore, need for expansion of IICT is absolutely justified and could be the right decision on the part of Govt. of India.

**Proposed Strategy:**

The proposed strategy for implementation of different issues, which mentioned above includes initiation of

- Addition of relevant disciplines like M.Tech in Carpet & Textile Management (CTM).
- Extension of R&D to cover the need of the academic and industry.
- To act over Strength, Weakness, Opportunity & Threats (SWOT)
- To serve more sectors like Fashion and Apparel besides wool, home textiles including Handmade and Machine made Carpet & designing.

Therefore, their course content, curriculum, fee structure, student selection mechanism etc. for the relevant disciplines and strategy /proposal for other activities need to be in place as has been included.

**Details available in point No.3**

**10.2 A flow chart for the intended fund flow mechanism may be indicated. Funds flows for all schemes/ projects in states should ordinarily be through the State Government.**

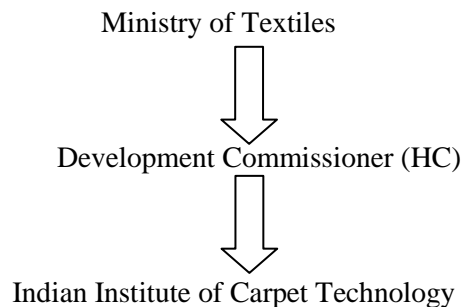

The Ministry of Textile (MOT) Government of India will release funds to the Indian Institute of Carpet Technology (IICT) as per approval of the scheme by the competent authority, availability of the budget, requisition of IICT and depending upon progress of utilization of funds release from time to time under the scheme.

**10.3 The monitoring framework for the project/ scheme may be indicated. The Arrangements for audit of the project may also be stated.**

The monitoring of the project will be done by the O/o Development Commissioner (Handicrafts), Ministry of Textiles, Government of India. The account will be audited by Internal & Statutory auditor.

## **11. Project/ Scheme sensitivities:**

**11.1 Any foreseeable constraints/ uncertainties which can affect the technical design, costing and implementation of the project may be indicated.**

Delay in sanction release of fund & execution.

**11.2 The likely impact of these constraints/ uncertainties on the project parameters may be stated. In particular, the sensitivity of the project cost, project schedule and project viability towards the possible constraints/ uncertainties may be mentioned.**

The fund allocation for the purpose will get utilized.

## **12. Project period:**

**12.1 The expected date of project completion may be stated. This should be realistic and supported with PERT Chart of the important activities, with a critical path analysis, identifying the main constraints.**

Project may be completed within time frame as above mentioned point no.1.3, subject to release/availability of fund.

**12.2 The project closure date should be also indicated beyond which further government support/ disbursement of funds will not be required.**

The implementation of the scheme will be for the XII Plan which will be over in 2018-19.

**12.3 A time line for the project deliverables (i.e. measurable deliverables phased year-wise) may be included.**

## **Summary of Expenditure in Rs. lakhs from 2016-17 to 2020-21**

### **Summary of Expenditure in Rs. lakhs from 2016-17 to 2020-21**

<b>Summary of activity</b>	<b>Non Recurring</b>	<b>Recurring</b>	<b>Total</b>	<b>Remarks</b>
<b>Continuation of existing B.Tech (CTT with specialization), M.Tech. in Carpet &amp; Textile Management (CTM) and other portfolios</b>	<b>5423.36</b>	<b>1417.87</b>	<b>6841.23</b>	<ul style="list-style-type: none"><li>• Details of Non-recurring expenditure as per <b>Annexure-V</b></li><li>• Details of Recurring expenditure as per <b>Annexure-VI</b></li></ul>

### **13.RCE proposals:**

**13.1 Details of physical progress achieved and expenditure incurred and commitment made so far may be given.**

Not applicable

**13.2 Date of latest approved, revised and proposed completion schedule of the project along with time overrun and reasons there of may be elaborated.**

Not applicable

**13.3 Item-wise cost variance between approved (latest) cost and revised cost as propose may be given.**

Not applicable

**13.4 Reasons of increase in cost may be given in the following manner**

- (a) Price Escalation**
- (b) foreign Exchange variation**
- (c) Statutory levies**
- (d) Change in Scope**
- (e) Addition/ deletion**
- (f) Under- estimation**
- (g) Others (to be specified)**

Not Applicable

**13.5 The underlying justification for increases in cost due to various factors may be explained.**

Not Applicable

**13.6 Effect of revision in capital cost estimates on cost of production and profitability/ viability with reference to earlier approved capital cost of the project**

Not Applicable

**13.7 Report of Standing Committee to fix the responsibility for cost and time overrun along with action taken report on its recommendations may be appended with the EFC/ PIB memo.**

Not Applicable

## **Conclusion:**

Over a decade, IICT contributed through its established portfolios particularly in HRD & R&D to a great extent to meet the existing gap. RFD of the institute is the expression of commitment for serving the trade. Further, IICT is committed to support the trade to take it to new heights in all relevant fronts.

## **Acknowledgement**

The Director, IICT & his team wish to record their sincere gratitude to Dr K. Gopal, I.A.S., Development Commissioner (Handicrafts) & Chairman IICT, Shri P.K.Thakur, Director (Handicrafts) & Vice-Chairman, E.C. Members and all stakeholders for their kind & continuous support which enabled the institute to reach mentioned height.

## **Introduction in prospective:**

The IICT after getting started in November 2001 could grow as desired to make it a Center-of-Excellence and endeavors made it to reach International Standard. However, achieving further excellence is in process. The further expansion of IICT became imperative due to following reasons:

- Optimum utilization of resource
- Addition of relevant disciplines like M.Tech in Textile Management
- Extension of R&D to cover the need of the academic and industry.
- To act over Strength, Weakness, Opportunity & Threats (SWOT)
- To serve more sectors like Fashion and Apparel besides wool, home textiles including Handmade and Machine made Carpet & designing.

## **FINAL CONCLUSION:**

1.The compliance to the resolution of EC dated 13.10.2012 has been made to facilitate decision whether to go for additional activity or not although continuation existing activity is a pre requisite.

2.Honble Vice Chancellor of the University was apprised about the expansion plan and his opinion in the form of message on the occasion of Institute Day celebrated on 01.11.2012 is reproduced below



Dr. R.K. Khandal  
Vice Chancellor



GAUTAM BUDDH TECHNICAL UNIVERSITY  
(Formerly Uttar Pradesh Technical University)  
I.E.T. Campus, Sitapur Road, Lucknow-226 021 (U.P.)

Dated : 01.11.2012

Sub.: Celebrations of 12<sup>th</sup> Institute Day on 1<sup>st</sup> Nov. 2012 by IICT; Our Message

Dear Prof. Goswami,

It is a matter of great pleasure to note that the faculty and students of IICT would be celebrating their Institute day, today. It would have been my honour to be personally present amongst you on this occasion but I am sorry to say that I would not be able to make it in spite of my keen desire to do so. Due to certain unforeseen reasons, I have to beg your pardon at the last moment.

In order to register our appreciation for your efforts, I would like to express that:

- (i) The social activities, such as 'Blood Donation', 'Creating awareness of Care & Fare School Children from carpet weavers' families etc. by students of IICT, are commendable.
- (ii) Director IICT and his whole team deserve kudos for the praise-worthy record of academic performance of the students. University acknowledges it as a remarkable achievement of IICT.
- (iii) The demand of change of name from "Indian Institute of Carpet Technology (IICT)" to Indian Institute of Carpet and Textile Technology (IICTT) seems relevant and worth considering.
- (iv) The plans of IICT to start new courses i.g. 'B.Tech in Fashion and Apparel Technology' and 'M.Tech in Textile Management' are appreciated. G.B. Technical University will provide all possible support necessary to affiliate these courses, in public interest.
- (v) Considering the research and academic potential, G.B.T.U. would encourage IICT for Pre-Ph.D mentoring/examination centre to promote scholastic activity.
- (vi) G.B. Technical University will extend all possible support for students and faculty.

With the above statements, I wish IICT -'An Institute with difference' functioning under the dynamic leadership and administrative control of Development Commissioner (Handicrafts) Ministry of Textiles, Govt. of India, a huge success in all its endeavours. Under the stewardship of Prof. Goswami, I have no doubt that IICT will certainly become a true international academic/research/referral centre in textiles.

I wish 12<sup>th</sup> Institute day a success and many happy returns of the day.

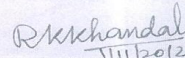
  
(Dr. R.K. Khandal)  
Vice Chancellor

Prof. (Dr.) K.K. Goswami  
Director  
Indian Institute of Carpet Technology (IICT)  
Chauri Road, Bhadohi-221401

Phones : (Off.): +91-522-2732194, (Fax): +91-522-2732189, (Res.): +91-522-2731631  
Email : rkhandal@upty.ac.in, vc@upty.ac.in Website: www.upty.ac.in

5. Further Feasibility Study was conducted, which is as under:

1. B.Tech. Course in Fashion and Apparel Technology &
2. M.Tech. in Textile Management.

**Note: Detailed report is annexed (Annexure-XI).**

6. In the meantime, competent authority has sanctioned a project entitled "Feasibility Study on up-gradation of IICT, Bhadohi to a national level Textile Institute" under R&D scheme based on a VIP reference as under:

वीरेन्द्र सिंह  
संसद सदस्य  
(लोक सभा)



आवास- स्वदेशी आश्रम  
इन्दिरा मिल घोराहा, चौरी रोड,  
जनपद- सन्त रविदास नगर भदोही  
पिन - 221401, उत्तर प्रदेश  
मो0 नं0 09452105009

पत्रांक : 00089/78BDH/MP

दिनांक : 27 अगस्त 2014

आदरणीय,

विकास आयुक्त हस्तशिल्प एवं अध्यक्ष आईआईसीटी, भदोही  
कार्यालय विकास आयुक्त हस्तशिल्प,  
पश्चिम खण्ड-7, आर.के. पुरम  
नई दिल्ली-110066

विषय: राष्ट्रहित एवं जनहित में आईआईसीटी, भदोही की उपयोगिता के सम्बन्ध में।

मैं हाल ही में आईआईसीटी, भदोही में दौरा किया यहाँ पर स्थापित जो विश्वस्तरीय सुविधाएँ बनायी गयी वह बहुत ही सराहनीय हैं मैंने आईआईसीटी, के अध्यापकों/अधिकारियों एवं स्टाफ तथा उद्योग जगत के लोगों से गहन बातचीत एवं आत्मनिरीक्षण के पश्चात् निम्न बातों का उल्लेख करना चाहता हूँ:-

1. आईआईसीटी, का विस्तार किया जा सकता है।
2. आईआईसीटी, का विस्तार डिम्ड विश्वविद्यालय के स्तर पर इण्डियन स्कूल ऑफ टेक्सटाइल के रूप में किया जाय।
3. इस विश्वविद्यालय में टेक्सटाइल के हर क्षेत्र के साथ-साथ कम्प्यूटर विज्ञान प्रबन्धन के क्षेत्र का भी समावेश रहेगा जिससे इण्डियन स्कूल ऑफ टेक्सटाइल पूर्ण एवं प्रभावशाली तरीके से कार्य करेगा।
4. इसके अलावा सम्बन्धित क्षेत्र के सभी व्यवसायिक प्रशिक्षण की भी सुविधा आईआईसीटी, भदोही में बनायी जाय जिससे अधिक से अधिक योग्य प्रशिक्षित व्यक्तियों को उद्योग जगत को दिया जाय।

अतः आपसे अपेक्षा की जाती है उपरोक्त विषय पर आप अपने सम्बन्धित अधिकारी को निर्देशित करें ताकि एक डी.पी.आर. (Detailed Project Report) आपके सक्षम आवश्यक कार्यवाही हेतु प्रस्तुत किया जाय तथा उसकी एक प्रति मुझे भी अग्रसारित किया जाय ताकि आगे की कार्यवाही हेतु माननीय वरन् मंत्री भारत सरकार से मिलकर आवश्यक कार्यवाही सुनिश्चित किया जाय। इस सम्बन्ध में हमारा पूरा सहयोग आवश्यकतानुसार समय-समय पर प्राप्त होता रहेगा।

भवदीय

वीरेन्द्र सिंह  
सांसद भदोही

22/10  
27/8/14

H.O.O/A 80/A.O/ DMC (K.S)

TO put up/whilere fana

27/8/14

27/8/14

The proposed expansion SFC-III in hand and above study may be integrated for the DPR. The experts engaged are invited in the presentation to be made on 23-11-2015 for participation.



ASO/AO  
Forma No. DMC  
to record the  
up. J  
3/11/15

Minutes of the meeting under the chairmanship of DC(HC)/Chairman IICT on 23<sup>rd</sup> November, 2015 at 530 PM with regard to the DPR for EFC/SFC under futuristic plan for expansion of IICT under Phase-III.

The list of participants:

1. Shri P.K. Thakur, Director, Handicrafts and vice chairman IICT
2. DR. KK Goswami, Director, IICT, Bhadohi

1. Initiating the discussion, Director IICT apprised about background of IICT as well about earlier EFC under Phase I & II, in the context of expansion.
2. Director IICT submitted the DPR and PowerPoint presentation vide letter number, 3/5/IICT/SFC/EFC/2015-16 dated 23-11-2015.
3. DC Handicrafts, expressed concern about employability of M-Tech (Carpet & Textile Management) pass out of the proposed program.
4. Integration of elements like entrepreneurship, fashion, information technology, accounting, finance, management including performance and project management in the existing B.Tech course was suggested.
5. The expansion of IICT as per DPR was accepted in principle.
6. For explaining the feasibility study report, the expert concerned Mr. KK Bajpai, was also present.
7. Introduction of M.Tech (Carpet & Textile Management) <sup>may be proposed only</sup> was suggested after identifying the industry relevance of the program.
8. It was advised to work on a proposed curriculum / syllabus for the proposed M.Tech (Carpet & Textile Management) program.
9. On the above background modification has been suggested integrating with the feasibility study titled as "Upgradation of IICT Bhadohi, to a national level textile institute" of university level under R&D scheme of o/o DCHC involving experts as approved by EC.

The meeting ended with vote of thanks to the chair.

(Alok Kumar)  
DC(HC), Chairman IICT

(P.K. Thakur)  
Director (HC), Vice Chairman IICT

DR. KK Goswami  
Director, IICT

DAK-44  
DATE 2/12/15



MINUTES OF 53<sup>rd</sup> EXECUTIVE COMMITTEE (EC) MEETING OF INDIAN INSTITUTE OF CARPET TECHNOLOGY (IICT), BHADOHI HELD ON 15.03.2016 AT 03.00 PM IN THE COMMITTEE ROOM OF O/O DC(HC), NEW DELHI.

The following members were present:

1. Dr. K. Gopal, IAS, Development Commissioner (Handicrafts) & Chairman, IICT.
2. Shri P.K.Thakur, Director (Handicrafts) Vice-Chairman, IICT.
3. Shri S.K.Gupta, ED, CEPC, New Delhi
4. Shri Bholanath Baranwal, BIL, G.T. Road Khachhawan, Varanasi
5. Dr.Arindam Basu, DG, NITRA,Ghaziabad
6. Shri G.S.Parashar, Dy.Director, Textile' Committee, New Delhi - Nominee-Secretary, TC,Mumbai
7. Shri Sanjay Singh, Jaipur Rugs, Jaipur-Nominee
8. Shri A.K.Kureel, Sr. A.D.(Institutional), O/o DC(HC), New Delhi
9. Dr. S.K.Pal, Professor, CPC & Registrar I/c, IICT-Director's Nominee
10. Shri R.K.Malik, Asso. Professor & Dean, IICT-Director's Nominee.
11. Prof.(Dr) K.K.Goswami, Director & Member Secretary, IICT

Leave of absence:

Rest other members of Executive Committee of IICT who could not attend.

1. Agenda Item No. 1. Welcome to Members

Chairman, IICT welcomed the members present in the meeting and thanked them for sparing their valuable time to attend the meeting. However, Director, IICT introduced the members to Chairman, IICT before starting the proceeding of meeting.

2. Agenda Item No. 2. Confirmation of Minutes

The committee confirmed the minutes of the 52<sup>nd</sup> EC Meeting held on 01.11.2015.

3.0 Agenda Item No 3. Action Taken Report on decision of EC/SGM Meetings up to dates:

The committee noted the action taken report on the decision of the committee and appreciated action taken & efforts made. However, the following observations on certain points have been made.

3.1 Futuristic Plan (SFC/EFC):

The committee noted the status of revised DPR for SFC as well "Feasibility study on up-gradation of IICT,Bhadohi to a national level Textile Institute" of university level in hand. The modified DPR integrated with feasibility study report be submitted by March end this year for subsequent necessary administrative action.

(K Gopal)  
Chairman

(P.K.Thakur)  
Vice-Chairman

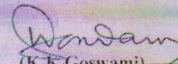
  
(K.K.Goswami)  
Member Secretary



**3.2 Conduction of Training under various projects/schemes including CHCDS/ ISDS.**

The committee noted the progress and status. The issue of disparity in stipend to trainees between IICT and CEPC run programme was also discussed. Therefore, the committee desired that in the next phase of training programme for 1500 trainees under CHCDS scheme, the stipend to be paid to trainees should be at par.

**3.3 Inverter Procurement and distribution:**

The committee noted the status and advised IICT Cell of o/o DC(HC) and IICT to make necessary follow up with IFW.

**3.4 Extension for Phase-II EFC:**

The committee noted status and advised IICT to follow up with IFW.

**3.5 IICT industry interface:** The committee was of the opinion to have strong synergy amongst IICT, Industry and CEPC so that adequate and qualitative national as well as international internship/placement for all intending students can take place. IICT to collect the career exhibition calendar for National and International level, organised by CEPC and submit a proposal for participation by IICT students/faculty/staffs to Director (HC) for subsequent proceeding.

**3.6 Progress of on going projects:** The committee noted the status as under;

IICT to submit UC for all completed projects by March 2016 end.

IICT sought extension for 9 R&D projects related to new technologies / studies which will be completed well before end of 2016-17.

The committee advised IICT to give scheme wise PPT presentation for the completed projects in front of Director(HC) and AD concerned at the earliest as convenient.

**3.7 Service Rule including TA-DA & Staff Promotion Schemes-MACP/CAS:** The committee noted the status. The IICT Cell o/o DC(HC) to communicate decision/approval.

**3.8 Reduction on Expenditure on use of Gen-Set. :** The committee has been apprised about the status that BIDA CEO will take up the matter in its next board meeting. However, committee desired that IICT to explore installation of solar system to comply the advice of ASFA during his visit to IICT-Bhadoli and submit a proposal in accordance for administrative decision.

**3.9 Extension centre of IICT:** As regard support to RCWPDS, the Satellite Centre of IICT at Jaipur in this regard a proposal to be submitted to seek approval of chairman on file.

**3.10 Recruitment for filling up of posts of IICT:** The Committee noted the status. IICT

to follow up with IICT Cell O/o DC(HC) to expedite the release of advertisement in employment news and in national dailies.

**3.11 Procurement:** The committee noted the status and emphasized the requirement. The decision of competent authority to be communicated by IICT Cell of O/o DC(HC).

(K.Gopal)  
Chairman

(P.K.Thakur)  
Vice-Chairman

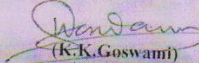
  
(K.K.Goswami)  
Member Secretary



3.12 **Expansion of IICT:** The committee noted the status about construction work in the new campus managed by Awasthi Vikash Parishad, Varanasi a UP Govt agency.

3.13 **Change in Admission criteria for Direct Admission in B.Tech 1<sup>st</sup> year against vacant seats:**

The committee noted the detailed study and interpretation in this regard. In view of the interpretation the committee accepted that the existing admission procedure to continue instead of conducting exam for direct admission.

3.14 **Progress Report:** The committee noted & appreciated the progress of Physical, Financial sponsored projects and RFD.

3.15 **Annual Action Plan and budget estimate for the FY 2016-17:** The committee noted the plan and outlay including for continued non plan support for pay and allowances in process. Recurring expenditure other than pay and allowances to be met from revenue fund. Non recurring expenditure to be carried out only after administrative/SFC approval.

#### 4.0 Agenda discussed and decision taken:

(i) **Cooperation of IICT Bhadohi to handover the Carpet Backing project to new S.P.V.:** The EC noted the fact sheet in this regard and resolved again that the decision of EC of IICT conveyed vide letter from DC(HC) stands correct and needs no further revision. After the issue of handover/takeover is over, SPV may approach IICT for any service for their quality management for which IICT to respond as per its policy, capability and tariff schedule without any liability.

(ii) **Annual Maintenance Contract (AMC):** The committee noted the requirement of maintenance of plant and equipments to keep them always in order. The committee further desired the maintenance of campus including building, road, house keeping sanitary, drainage and sewerage etc also to be covered under AMC. A detailed proposal with background, justification and financial implication be submitted for taking administrative approval of Chairman, IICT.

#### 5.0 Other matter discussed and decided:

**Repositioning of IICT:** The Chairman, IICT appreciated that IICT is doing well but there should be no space for complacency. Therefore, it was specifically desired that IICT to prepare a road map in a manner to reposition itself to meet the emergent needs like capacity building, visionary approach and promotional activities like Mobile labs, Entrepreneurship development Programme (EDP) for artisans & youth for deriving demographic dividend, outreach across the country, true referral centre as a repository for carpet sector in particular and submit to Chairman, IICT.

Meeting ended with vote of thanks to the chair.

(K Gopal)  
Chairman

(P.K.Thakur)  
Vice-Chairman

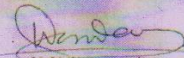
  
(K.K.Goswami)  
Member Secretary

Page 3 of 3

# ANNEXURES

S. No.	Contents	Annexure No.
1	Resolution in SGM's	I
2	Minutes of meeting IICT Staffs on Phase III	II
3	LIC's email on NR Budget Estimate and Master Plan	III
4	Minutes of EFC & SFC	IV
5	Break up of target revenue (RG)	V
6	Proposed recurring expenditure (RE)	VI
7	Annual Report for 2014-15	VII
8	Kaleen Bandhu Brochure	VIII
9	Publications on handmade carpets: Socio Economic	IX
10	Publication by AATCC on Carpet pile stability	X
11	Feasibility Study Report	XI

To,  
Development Commissioner (Handicrafts)  
O/o DC (HC), West Block No.-VII  
R.K.Puram,  
New Delhi-110 066

**Subject: Modified DPR for EFC/SFC for continuation of existing activities of IICT, Bhadohi-reg.**

**Sir,**

This refers to above mentioned subject, in this regard, EC of IICT resolved vide meeting dated as under-

**Meeting dated 13-06-2014:**

*“In view of consideration of coverage of Pay & Allowances under Non Plan for IICT by the Ministry of Textiles, DC (HC) desired IICT to assist IICT Cell of O/o DC(HC) in formulation of the modified EFC document excluding the Pay & Allowances, for subsequent action at the earliest.” (copy of minute enclosed)*

**Meeting dated 08-09-2015:**

*“The committee advised IICT Cell of O/o DC(HC)\_ to return the DPR to Director, IICT with the advised to submit revised DPR incorporating additional emerging inputs. Further Chairman, IICT advised to complete “ Feasibility study of Up-gradation of IICT to national level Textile Institute” of University level at earliest following a roadmap engaging relevant experts with due intimation to Vice-Chairman, IICT.” (copy of minute enclosed)*

Further to above O/o Development Commissioner (HC) vide letter No.I-11020/14/2015-16/IICT/444 dated 09-11-2015, directed by the Development Commisisoner (HC) to make lucid presentation on 23-11-2015 at 3 PM.

In compliance to above, enclosed please find the fresh DPR (duly filled in EFC/SFC format/memorandum). However, PPT presentation is proposed to be made on 23-11-2015 in the O/o Development Commissioner (HC)

Submitted for taking necessary action for proposed expansion programme including continuation of existing activities in respect of Indian Institute of Carpet Technology, Bhadohi.

**Yours faithfully**

**Prof. (Dr) K.K.Goswami  
Director, IICT**



5A

COURSE CURRICULA FOR  
MES

**Course Curricula**

**for**

**Short Term Courses based on  
Modular Employable Skills (MES)**

**in**

**Carpet Sector**



**DIRECTORATE GENERAL OF EMPLOYMENT AND TRAINING  
MINISTRY OF LABOUR & EMPLOYMENT  
GOVERNMENT OF INDIA**

## Course Curricula for Short Term Courses based on Modular Employable Skills (MES) in the Carpet Sector

### CONTENTS

S. No.	Particular	Page No.
1.	Background	2
2.	Frame work for Skill Development based on ' <b>Modular Employable Skills (MES)</b> '	2
3.	Curriculum Development Process	3
4.	Duration of the Programme	4
5.	Pathways to acquire Qualification	4
6.	Course Matrix	5
7.	<b>Modules:</b>	7
8.	Handknotted Woolen Carpet Manufacturing	7
9.	Tibbetan Carpet Manufacturing	8
10.	Flat woven Dhurrie Manufacturing	9
11.	Hand Spinning of Woolen Carpet Yarn	10
12.	Hand Spinning of Cotton Carpet Yarn	11
13.	Hand tufted Carpet Manufacturing	12
14.	Broadloom Carpet Manufacturing	13
15.	Carpet Yarn Dyeing	14
16.	Carpet Finishing – I	16
17.	Manufacture of fabric related to Carpet	17
18.	Entrepreneurship & Export Management	18
19.	Hand knotted Silk Carpet Manufacturing	19
20.	Natural Fibres for Carpets	21
21.	Spinning of Woolen Carpet yarn	22
22.	Spinning of Cotton Carpet yarn	23
23.	Carpet Backing	24
24.	Carpet yarn dyeing with Natural Dyes	25
25.	Carpet Finishing - II	26
26.	Designing of fabric related to Carpet	27
27.	Modern Carpet Yarn Manufacturing	28
28.	List of Expert/ Committee Members	29

## Skill Development based on Modular Employable Skills (MES)

### Background

---

The need for giving emphasis on the Skill Development, especially for the less educated, poor and out of school youth has been highlighted in various forums. The skill level and educational attainment of the work force determines the productivity, income levels as well as the adaptability of the working class in changing environment. Large percentage of population in India is living below poverty line. One of the important causes is lower percentage of skilled persons in the workforce

The skill development at present is taking place mostly in the informal way, i.e. persons acquire skill at the work-place when they help their parents, relatives and employers etc. Such persons do not have a formal certificate and thus earn lower wages and are exploited by employers. They have come through informal system due to socio-economic circumstances of the family and the compulsions of earning a livelihood rather than attending a formal course. While their productivity is low, their contribution to the national GDP cannot be ignored. If the country can create a system of certification which not only recognizes their skills but also provides education and training in a mode that suits their economic compulsions, it will not only benefit the workforce to earn a decent living but also contribute to the national economy by better productivity of this workforce.

Another related problem to be tackled is large number of students drop outs (About 63% of the school students drop out at different stages before reaching Class-X).

### Frame work for Skill Development based on 'Modular Employable Skills (MES)'

---

Very few opportunities for skill development are available for the above referred groups (out of school youth & existing workers especially in the informal sector). Most of the existing Skill Development programmes are long term in nature. Poor and less educated persons can not afford long term training programmes due to higher entry qualifications, opportunity cost etc. Therefore, a new frame work for Skill Development for the Informal Sector has been evolved by the DGET to address to the above mentioned problems. The **key features of the new frame work for skill development** are:

- Demand driven Short term training courses based on modular employable skills decided in consultation with Industry
- Flexible delivery mechanism (part time, weekends, full time)
- Different levels of programmes (Foundation level as well as skill upgradation) to meet demands of various target groups
- Central Government will facilitate and promote training while Vocational Training (VT) Providers under the Govt. and Private Sector will provide training
- Optimum utilisation of existing infrastructure to make training cost effective.
- Testing of skills of trainees by independent assessing bodies who would not be involved in conduct of the training programme, to ensure that it is done impartially.
- Testing & certification of prior learning (skills of persons acquired informally)

The Short Term courses would be based on 'Modular Employable Skills (MES)'.

The **concept for the MES** is :

- D Identification of 'minimum skills set' which is sufficient to get an employment in the labour market.
- D It allows skills upgradation, multiskilling, multi entry and exit, vertical mobility and life long learning opportunities in a flexible manner.
- D It also allows recognition of prior learning (certification of skills acquired informally) effectively.
- D The modules in a sector when grouped together could lead to a qualification equivalent to National Trade Certificate or higher.
- D Courses could be available from level 1 to level 3 in different vocations depending upon the need of the employer organisations.
- D MES would benefit different target groups like :
  - o Workers seeking certification of their skills acquired informally
  - o workers seeking skill upgradation
  - o early school drop-outs and unemployed
  - o previously child labour and their family

### **Age of participants**

---

The minimum age limit for persons to take part in the scheme is 14 years but there is no upper age limit.

### **Curriculum Development Process**

---

Following procedure is used for developing course curricula

- Identification of Employable Skills set in a sector based on division of work in the labour market.
- Development of training modules corresponding to skills set identified so as to provide training for specific & fit for purpose
- Organization of modules in to a Course Matrix indicating vertical and horizontal mobility. The course matrix depicts pictorially relation among various modules, pre requisites for higher level modules and how one can progress from one level to another.
- Development of detailed curriculum and vetting by a trade committee and by the NCVT

(Close involvement of Employers Organizations, State Governments, experts, vocational training providers and other stake holders is ensured at each stages).

### **Development of Core Competencies**

---

Possession of proper attitudes is one of the most important attribute of a competent person. Without proper attitudes, the performance of a person gets adversely affected. Hence, systematic efforts will be made to develop attitudes during the training programme.

The trainees deal with men, materials and machines. They handle sophisticated tools and instruments. Positive attitudes have to be developed in the trainees by properly guiding them

and setting up examples of good attitudes by demonstrated behaviors and by the environment provided during training.

Some important core competencies to be developed are:

1. Safety consciousness and safe working practices
2. Care of equipment and tools
3. Punctuality, discipline and honesty
4. Concern for quality
5. Respect for rules and regulations
6. Concern for health and hygiene
7. Cordial relationship and Cooperation with co-workers and team Work
8. Positive attitude and behavior
9. Responsibility and accountability
10. Learn continuously
11. Communication Skills
12. Concern for environment and waste disposal

Following competencies should also be developed during level-II and higher courses:

1. Ability for planning, organizing and coordinating
2. Creative thinking, problem solving and decision making
3. Leadership
4. Ability to bear stress
5. Negotiation

### **Duration of the Programmes**

---

Time taken to gain the qualification will vary according to the pathway taken and will be kept very flexible for persons with different backgrounds and experience. Duration has been prescribed in hours in the curriculum of individual module, which are based on the content and requirements of a MES Module. However, some persons may take more time than the prescribed time. They should be provided reasonable time to complete the course.

### **Pathways to acquire Qualification:**

---

**Access to** the qualification could be through:

- An approved training programme; **Or**
- A combination of an approved training programme plus recognition of prior learning including credit transfer; **Or**
- The recognition of prior learning that provides evidence of the achievement of the competencies for the qualification.

## **Methodology**

---

The training methods to be used should be appropriate to the development of competencies. The focus of the programme is on “performing” and not on “Knowing”. Lecturing will be restricted to the minimum necessary and emphasis to be given for ‘hands on training’.

The training methods will be individual centered to make each person a competent one. Opportunities for individual work will be provided. The learning process will be continuously monitored and feedback will be provided on individual basis.

Demonstrations using different models, audio visual aids and equipment will be used intensively.

## **Instructional Media Packages**

---

In order to maintain quality of training uniformly all over the country, instructional media packages (IMPs) will be developed by the National Instructional Media Institute (NIMI), Chennai.

## **Assessment**

---

DGE&T will appoint assessing bodies to assess the competencies of the trained persons. The assessing body will be an independent agency, which will not be involved in conducting the training programmes. This, in turn, will ensure quality of training and credibility of the scheme. Keeping in view the target of providing training/testing of one million persons through out the country and to avoid monopoly, more than one assessing bodies will be appointed for a sector or an area.

## **Certificate**

---

Successful persons will be awarded certificates issued by National Council for Vocational Training (NCVT).



# COURSE MATRIX based on MODULAR EMPLOYERABLE SKILLS for the CARPET SECTOR

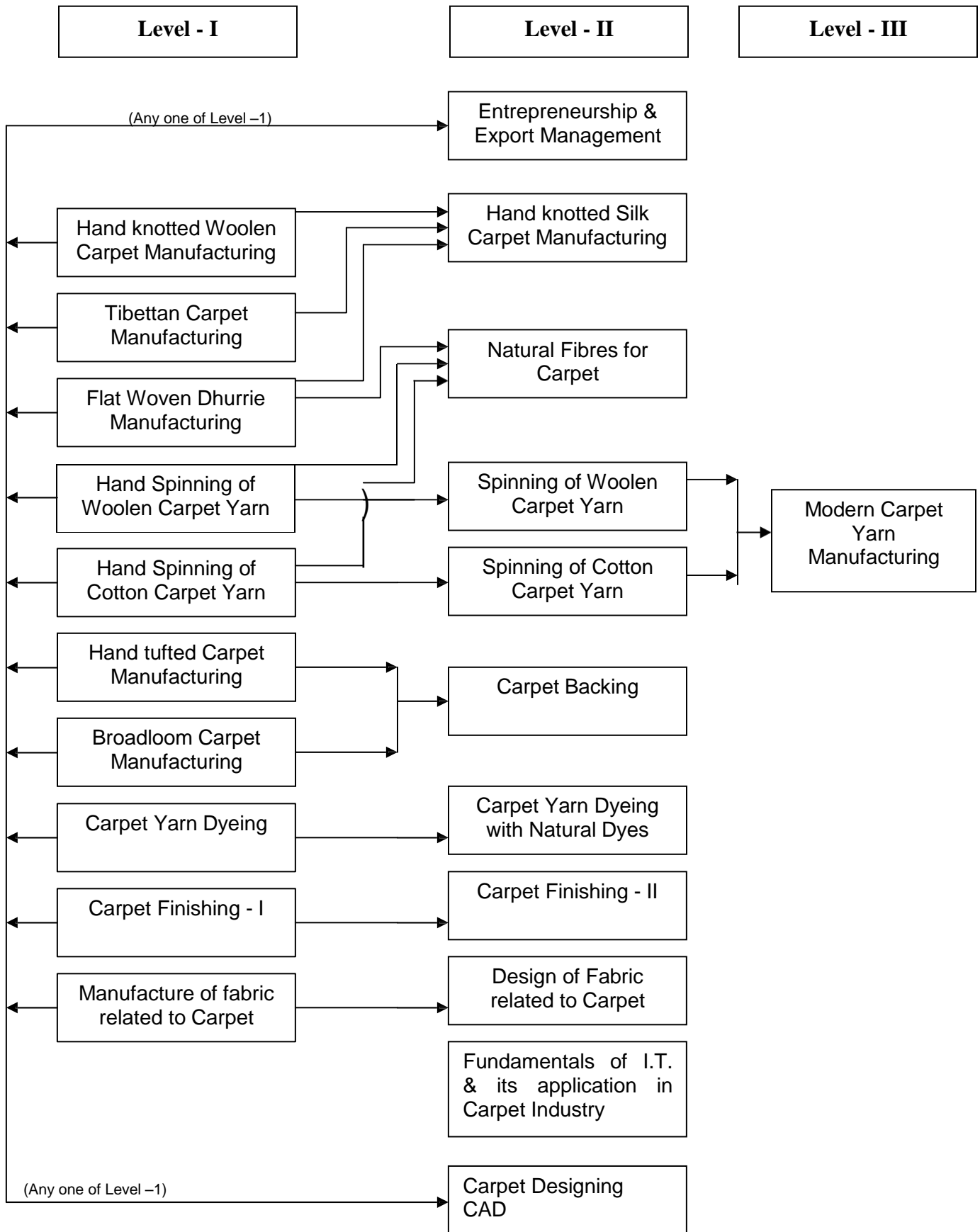

## **MODULE – 1 (Certificate Level – I)**

<b>NAME</b>	:	Handknotted Woolen Carpet Manufacturing
<b>SECTOR/ CODE</b>	:	<b>Carpet / CAR101</b>
<b>ENTRY QUALIFICATION</b>	:	Class V Age: 14 years
<b>TERMINAL COMPETENCY</b>	:	After completion of course the candidate would be able to make hand knotted carpet.
<b>DURATION</b>	:	240 hrs
<b>CONTENT</b>	:	Carpet manufacturing in hand knotted loom.

<b>Practical Competencies</b>	<b>Underpinning Knowledge (Theory)</b>
<ul style="list-style-type: none"><li>• Identification of various tools &amp; equipment &amp; material.</li><li>• Safe working practices.</li><li>• Warping</li><li>• Preparation of warp beam &amp; mounting on the loom</li><li>• Warp setting</li><li>• Knot setting</li><li>• Knotting on the loom on the basis of design</li><li>• Measurement &amp; control of pile height, knot density, waste, dimension etc</li></ul>	<ul style="list-style-type: none"><li>• Study of sequence of operations</li><li>• Methods of transferring the design to carpet.</li><li>• Defects in manufacturing carpet and remedial measures.</li></ul>

### **TOOLS AND EQUIPMENT FOR A BATCH OF 20 TRAINEES**

<b>S. NO.</b>	<b>DESCRIPTION</b>	<b>QUANTITY</b>
1	Hand knotted looms	05
2	Beaters	20
3	Knife	20
4	Pile height gauge	01 set
5	Scissors	20
6	Weighing Balance	01

## **MODULE – 2 (Certificate Level – I)**

**NAME** : Tibetan Carpet Manufacturing

**SECTOR/ CODE** : **Carpet / CAR102**

**ENTRY QUALIFICATION** : Class V Age: 14 years

**TERMINAL COMPETENCY** : After completion of course the candidate would be able to make tibbat carpet.

**DURATION** : 240 hrs

**CONTENT** : Carpet manufacturing in tibbat loom.

<b>Practical Competencies</b>	<b>Underpinning Knowledge (Theory)</b>
<ul style="list-style-type: none"><li>• Identification of various tools &amp; equipment &amp; material.</li><li>• Safe working practices.</li><li>• Warping</li><li>• Preparation of warp beam &amp; mounting on the loom</li><li>• Warp setting</li><li>• Knot setting</li><li>• Knotting on the loom on the basis of design</li><li>• Measurement &amp; control of pile height, knot density, waste, dimension etc</li><li>• Inspection &amp; Mending of the defects</li></ul>	<ul style="list-style-type: none"><li>• Study of sequence of operations</li><li>• Methods of transferring the design to carpet.</li><li>• Defects in manufacturing carpet and remedial measures.</li></ul>

### **TOOLS AND EQUIPMENT FOR A BATCH OF 20 TRAINEES**

<b>S. NO.</b>	<b>DESCRIPTION</b>	<b>QUANTITY</b>
1	Tibbat looms	05
2	Beater	20
3	Knife	20
4	Scissor	20
5	Iron Rod	20

### **MODULE – 3 (Certificate Level – I)**

<b>NAME</b>	:	Flat woven Dhurrie Manufacturing
<b>SECTOR/ CODE</b>	:	<b>Carpet / CAR103</b>
<b>ENTRY QUALIFICATION</b>	:	Class V Age: 14 years
<b>TERMINAL COMPETENCY</b>	:	After completion of course the candidate would be able to make dhurries
<b>DURATION</b>	:	240 hrs
<b>CONTENT</b>	:	Carpet manufacturing in flat woven method

<b>Practical Competencies</b>	<b>Underpinning Knowledge (Theory)</b>
<ul style="list-style-type: none"><li>• Identification of various tools &amp; equipment &amp; material.</li><li>• Safe working practices.</li><li>• Warping on the loom</li><li>• Practice of weaving according to the design on flat looms to make dhurries</li><li>• Inspection &amp; Mending of defects</li></ul>	<ul style="list-style-type: none"><li>• Study of sequence of operations</li><li>• Methods of transferring the design to carpet.</li><li>• Defects in manufacturing carpet and remedial measures</li></ul>

#### **TOOLS AND EQUIPMENT FOR A BATCH OF 20 TRAINEES**

<b>S. NO.</b>	<b>DESCRIPTION</b>	<b>QUANTITY</b>
1	Dhurrie looms	10
2	Beater	20

## **MODULE – 4 (Certificate Level – I)**

**NAME** : Hand spinning of Woolen Carpet Yarn

**SECTOR/ CODE** : **Carpet / CAR104**

**ENTRY QUALIFICATION** : Class V Age: 14 years

**TERMINAL COMPETENCY** : After completion of the course the trained person would be able to spin woolen yarn in hand spinning system

**DURATION** : 240 hours

**CONTENT** : Spinning

<b>Practical Competencies</b>	<b>Underpinning Knowledge (Theory)</b>
<ul style="list-style-type: none"><li>• Identification of wool fibre</li><li>• Operation of Gandhi &amp; Ambar charkha for producing woolen yarn</li><li>• Measurement &amp; control of Count &amp; Twist</li><li>• Measurement &amp; control of yarn realisation</li><li>• Practice Do's &amp; Don'ts</li></ul>	<ul style="list-style-type: none"><li>• Study of wool fibre</li><li>• Study of tools and materials required for manufacturing hand spun woolen yarn.</li><li>• Study of feed material required for manufacturing hand spun woolen yarn of the desired count</li><li>• Study of different product setting parameters</li><li>• Study on yarn realisation</li><li>• Do's &amp; Don'ts</li></ul>

### **TOOLS AND EQUIPMENT FOR A BATCH OF 20 TRAINEES**

<b>S. NO.</b>	<b>DESCRIPTION</b>	<b>QUANTITY</b>
1	Gandhi Charkha for spinning	05
2	Ambar Charkha	05
3	Calculator	01
4	Scale	20
5	Tape	20
6	Wrap Reel	01
7	Weighing Balance	01
8	Twist tester	01

## **MODULE – 5 (Certificate Level – I)**

<b>NAME</b>	:	Hand spinning of Cotton Carpet Yarn
<b>SECTOR/ CODE</b>	:	<b>Carpet/ CAR105</b>
<b>ENTRY QUALIFICATION</b>	:	Class V Age: 14 years
<b>TERMINAL COMPETENCY</b>	:	After completion of the course the trained person would be able to spin cotton yarn in hand spinning system
<b>DURATION</b>	:	240 hours
<b>CONTENT</b>	:	Spinning

<b>PRACTICAL</b>	<b>THEORY</b>
<ul style="list-style-type: none"> <li>• Identification of cotton fibre</li> <li>• Operation of Gandhi &amp; Ambar charkha for producing cotton yarn</li> <li>• Measurement &amp; control of Count &amp; Twist</li> <li>• Measurement &amp; control of yarn realisation</li> <li>• Practice Do's &amp; Don'ts</li> </ul>	<ul style="list-style-type: none"> <li>• Study of cotton fibre</li> <li>• Study of tools and materials required for manufacturing hand spun cotton yarn.</li> <li>• Study of feed material required for manufacturing hand spun cotton yarn of the desired count</li> <li>• Study of different product setting parameters</li> <li>• Study on yarn realisation</li> <li>• Do's &amp; Don'ts</li> </ul>

### **TOOLS AND EQUIPMENT FOR A BATCH OF 20 TRAINEES**

1	Gandhi Charkha for spinning	05
2	Ambar Charkha	05
3	Calculator ,	01
4	Scale	20
5	Tape	20
6	Wrap Reel	01
7	Weighing Balance	01
8	Twist tester	01

### **MODULE – 6 (Certificate Level – I)**

<b>NAME</b>	:	Hand tufted Carpet Manufacturing
<b>SECTOR/ CODE</b>	:	<b>Carpet / CAR106</b>
<b>ENTRY QUALIFICATION</b>	:	Class V Age: 14 years
<b>TERMINAL COMPETENCY</b>	:	After completion of course the candidate would be able to make tufted carpet.
<b>DURATION</b>	:	240 hrs
<b>CONTENT</b>	:	Carpet manufacturing in tufting method

<b>Practical Competencies</b>	<b>Underpinning Knowledge (Theory)</b>
<ul style="list-style-type: none"> <li>• Identification of various tools &amp; equipment &amp; material.</li> <li>• Safe working practices.</li> <li>• Stretching of the primary fabric on loom</li> <li>• Inspection &amp; Analysis of primary, secondary &amp; third backing fabric including yarn used for tufting</li> <li>• Maintenance of tufting gun</li> <li>• Transferring the design from trace paper to fabric</li> <li>• Practice of tufting on tufted loom</li> <li>• Inspection &amp; Mending of the defects</li> </ul>	<ul style="list-style-type: none"> <li>• Study of sequence of operations</li> <li>• Study of primary, secondary &amp; third backing fabric including yarn used for tufting</li> <li>• Study of various tufting guns</li> <li>• Methods of transferring the design to carpet.</li> <li>• Defects in manufacturing carpet and remedial measures.</li> </ul>

#### **TOOLS AND EQUIPMENT FOR A BATCH OF 20 TRAINEES**

<b>S. NO.</b>	<b>DESCRIPTION</b>	<b>QUANTITY</b>
1	Tufting frame	10
2	Tufting Guns	20



## **MODULE – 7 (Certificate Level – I)**

<b>NAME</b>	:	Broad loom Carpet Manufacturing
<b>SECTOR/ CODE</b>	:	<b>Carpet / CAR107</b>
<b>ENTRY QUALIFICATION</b>	:	Class V      Age: 14 years
<b>TERMINAL COMPETENCY</b>	:	After completion of course the candidate would be able to make broad loom carpet.
<b>DURATION</b>	:	240 hrs
<b>CONTENT</b>	:	Carpet manufacturing in broad loom

<b>Practical Competencies</b>	<b>Underpinning Knowledge (Theory)</b>
<ul style="list-style-type: none"><li>• Identification of various tools &amp; equipment &amp; material.</li><li>• Safe working practices.</li><li>• Warping out side the loom</li><li>• Beam setting on the loom</li><li>• Weft preparation</li><li>• Machine setting</li><li>• Practice of weaving on broadloom.</li><li>• Inspection &amp; Mending of defects</li></ul>	<ul style="list-style-type: none"><li>• Study of sequence of operations</li><li>• Methods of transferring the design to carpet.</li><li>• Defects in manufacturing carpet and remedial measures.</li></ul>

### **TOOLS AND EQUIPMENT FOR A BATCH OF 20 TRAINEES**

<b>S. NO.</b>	<b>DESCRIPTION</b>	<b>QUANTITY</b>
1	Broad looms with all necessary equipments	02

## **MODULE – 8 (Certificate Level – I)**

<b>NAME</b>	:	Carpet Yarn Dyeing
<b>SECTOR/ CODE</b>	:	<b>Carpet / CAR108</b>
<b>ENTRY QUALIFICATION</b>	:	Class V Age: 14 years
<b>TERMINAL COMPETENCY</b>	:	After completion of the course the trained person would be able to handle yarn dyeing machine to dye wool/silk/art silk yarn.
<b>DURATION</b>	:	240 hours
<b>CONTENT</b>	:	Carpet Yarn (Wool/ Silk/art silk ) Dyeing

<b>Practical Competencies</b>	<b>Underpinning Knowledge (Theory)</b>
<ul style="list-style-type: none"> <li>• Identification of various tools &amp; equipment &amp; material.</li> <li>• Safe working practices.</li> <li>• Wool/Silk/Art. Silk identification.</li> <li>• Operation of dyeing machine.</li> <li>• Dye stuffs identification</li> <li>• Practice of Dyeing of wool</li> <li>• Practice of Dyeing of silk</li> <li>• Practice of Dyeing of Art. Silk</li> <li>• Shade Matching</li> <li>• Checking of colour fastness to washing, rubbing etc.</li> </ul>	<ul style="list-style-type: none"> <li>• Study of wool/silk/art silk Fibre</li> <li>• Study of Sequence of operations</li> <li>• Importance of machine parameters of dyeing.</li> <li>• Different type of machines used for Carpet Yarn Dyeing</li> <li>• Function of dyes, chemicals &amp; auxiliaries</li> <li>• Recipe, Colour Fastness and shade matching</li> </ul>

### **TOOLS AND EQUIPMENT FOR A BATCH OF 20 TRAINEES**

<b>S. NO.</b>	<b>DESCRIPTION</b>	<b>QUANTITY</b>
1.	Cabinet type dyeing machine	01
2.	S. S. Vessels (03 litres)	20
3.	Heating arrangements	10
4.	Beakers (1000 c.c.)	20
5.	Pipette (25 c.c.)	20
6.	Weighing Balance	01 set
7.	Grey Scale	01 set
8.	Crock meter	01 set
9.	Launderometer	01 set

### **MODULE – 9 (Certificate Level – I)**

<b>NAME</b>	:	Carpet Finishing - I
<b>SECTOR/ CODE</b>	:	<b>Carpet / CAR109</b>
<b>ENTRY QUALIFICATION</b>	:	Class V Age: 14 years
<b>TERMINAL COMPETENCY</b>	:	After completion of course, the candidates would be able to do woolen carpet Washing.
<b>DURATION</b>	:	240 hours
<b>CONTENT</b>	:	All types of carpet Washing

<b>Practical Competencies</b>	<b>Underpinning Knowledge (Theory)</b>
<ul style="list-style-type: none"><li>• Identification of various tools &amp; equipment &amp; material.</li><li>• Safe working practices.</li><li>• Practice of washing of handknotted woolen carpet using chemicals and herbal products</li><li>• Practice of washing of hand tufted woolen carpet using chemicals and herbal products</li><li>• Monitoring &amp; control of neutralization &amp; moisture content</li><li>• Practice of after wash process like drying</li><li>• Monitoring &amp; control of residual moisture content</li></ul>	<ul style="list-style-type: none"><li>• Scope &amp; objective of washing</li><li>• Recipes</li><li>• Function of all ingredients</li><li>• Defects of carpets and their remedial measures.</li><li>• Eco-friendliness</li></ul>

### **TOOLS AND EQUIPMENT FOR A BATCH OF 20 TRAINEES**

<b>S. NO.</b>	<b>DESCRIPTION</b>	<b>QUANTITY</b>
1.	Washing Platform	01
2.	Washing Scrapper	20
3.	Chemical Containers	10
4.	Moisture Meter	02
5.	pH paper/ Meter	20 sets

## **MODULE – 10 (Certificate Level – I)**

**NAME** : Manufacture of fabric related to Carpet

**SECTOR/ CODE** : **Carpet/ CAR112**

**ENTRY QUALIFICATION** : Class V Age: 14 years

**TERMINAL COMPETENCY** : The participants will be able to weave the fabrics related to Carpets

**DURATION** : 150 hours

**CONTENT** : Fabric Manufacture

<b>Practical Competencies</b>	<b>Underpinning Knowledge (Theory)</b>
<ul style="list-style-type: none"><li>• Identification of various tools &amp; equipment &amp; material.</li><li>• Safe working practices.</li><li>• Operation of looms</li><li>• Practice of beam gaiting</li><li>• Practice of loom setting</li><li>• Practice of Design setting</li><li>• Practice of repairing of thread breaks</li><li>• Inspection &amp; Mending of defects</li></ul>	<ul style="list-style-type: none"><li>• Study of sequence of operations</li><li>• Parts of the loom &amp; its function</li><li>• Motion of the loom &amp; Mechanism behind</li><li>• Specification of fabrics related to carpet/ home furnishing</li><li>• Theory of loom/setting</li><li>• Theory of cloth setting</li><li>• Basics of Fabric Design</li><li>• Study of fabric defects</li></ul>

### **TOOLS AND EQUIPMENT FOR A BATCH OF 20 TRAINEES**

<b>S. NO.</b>	<b>DESCRIPTION</b>	<b>QUANTITY</b>
1.	Pick Glass	10
2.	Looms	03
3.	Fabric Inspection Table	01

## **MODULE – 11 (Certificate Level – II)**

<b>NAME</b>	:	Entrepreneurship and Export Management
<b>SECTOR/ CODE</b>	:	<b>Carpet / CAR214</b>
<b>ENTRY QUALIFICATION</b>	:	10 <sup>th</sup> standard & 14 years of age, any one of level-I MES module
<b>TERMINAL COMPETENCY</b>	:	After completion of the course, the participants will be able to manage export documentation of EOU or initiate & manage a small scale manufacturing unit on their own
<b>DURATION</b>	:	240 hours
<b>CONTENT</b>	:	Entrepreneurship and Export Management

<b>Practical Competencies</b>	<b>Underpinning Knowledge (Theory)</b>
<ul style="list-style-type: none"> <li>• Identification of various tools &amp; equipment &amp; material.</li> <li>• Safe working practices.</li> <li>• Preparation of various export documents</li> <li>• Survey &amp; data basing</li> <li>• Preparation of project cum feasibility report for setting up a small scale company</li> </ul>	<ul style="list-style-type: none"> <li>• Types of export documents</li> <li>• L/C and its types</li> <li>• Regulatory requirements of various countries</li> <li>• Basic requirements for entrepreneurs</li> <li>• Basics of production, financial marketing management</li> <li>• Govt. schemes for development of entrepreneurship &amp; employment promotion schemes</li> <li>• Managing people</li> </ul>

### **TOOLS AND EQUIPMENT FOR A BATCH OF 20 TRAINEES**

<b>S. NO.</b>	<b>DESCRIPTION</b>	<b>QUANTITY</b>
1.	Computer	05
2.	Set of Standard documents	20
3.	LCD Projector	01

## MODULE – 12 (Certificate Level – II)

<b>NAME</b>	:	Handknotted Silk Carpet Manufacturing
<b>SECTOR/ CODE</b>	:	<b>Carpet / CAR210</b>
<b>ENTRY QUALIFICATION</b>	:	Class V Age: 14 years MES module on any one of the following: <ul style="list-style-type: none"> <li>• Hand knotted woolen carpet manufacturing</li> <li>• Tibetan Carpet Manufacturing</li> <li>• Flat woven Dhurrie Manufacturing</li> </ul>
<b>TERMINAL COMPETENCY</b>	:	After completion of course the candidate would be able to make knotted carpet in silk
<b>DURATION</b>	:	240 hrs
<b>CONTENT</b>	:	Silk Carpet manufacturing in hand knotted loom.

<b>Practical Competencies</b>	<b>Underpinning Knowledge (Theory)</b>
<ul style="list-style-type: none"> <li>• Identification of various tools &amp; equipment &amp; material.</li> <li>• Safe working practices.</li> <li>• Warping</li> <li>• Preparation of warp beam &amp; mounting on the loom</li> <li>• Warp setting</li> <li>• Knot setting</li> <li>• Knotting on the loom on the basis of design</li> <li>• Measurement &amp; control of pile height, knot density, waste, dimension etc</li> </ul>	<ul style="list-style-type: none"> <li>• Study of sequence of operations</li> <li>• Methods of transferring the design to carpet.</li> <li>• Defects in manufacturing carpet and remedial measures.</li> </ul>

## TOOLS AND EQUIPMENT FOR A BATCH OF 20 TRAINEES

<b>S. NO.</b>	<b>DESCRIPTION</b>	<b>QUANTITY</b>
1	Hand knotted looms	05
2	Beaters	20
3	Knife	20
4	Pile height gauge	01 set
5	Scissors	20
6	Weighing Balance	01



## MODULE – 13 (Certificate Level – II)

<b>NAME</b>	:	Natural Fibres for Carpets
<b>SECTOR/ CODE</b>	:	<b>Carpet / CAR211</b>
<b>ENTRY QUALIFICATION</b>	:	5 <sup>th</sup> Standard & 14 years of age. MES module on one of the following: <ul style="list-style-type: none"> <li>• Flat woven Dhurrie Manufacturing</li> <li>• Hand spinning of Cotton Carpet Yarn</li> <li>• Hand spinning of woolen Carpet Yarn</li> </ul>
<b>TERMINAL COMPETENCY</b>	:	After completion of the course the trained person would be able to manufacture natural fibre based yarn applicable to carpet/floor coverings
<b>DURATION</b>	:	240 hours
<b>CONTENT</b>	:	Fibre identification, their spinning, chemical processing and product development in terms of carpets/ floor covering.

<b>Practical Competencies</b>	<b>Underpinning Knowledge (Theory)</b>
<ul style="list-style-type: none"> <li>• Identification of various tools &amp; equipment &amp; material.</li> <li>• Safe working practices.</li> <li>• Identification of fibres.</li> <li>• Operation of related spinning techniques</li> <li>• Operation of related Process of dyeing</li> <li>• Operation of related process of Weaving</li> </ul>	<ul style="list-style-type: none"> <li>• Description of different unconventional Natural Fibres, their properties &amp; end use applications.</li> <li>• Study on sequence of operation on yarn spinning</li> <li>• Study on operation in dyeing</li> <li>• Study on operations in related chemical treatments</li> <li>• Study on process of weaving of natural fibre based yarns</li> </ul>

### TOOLS AND EQUIPMENT FOR A BATCH OF 20 TRAINEES

S. NO.	DESCRIPTION	QUANTITY
1.	Hand Spinning Machine	10
2.	S. S. Vessels (03 litres)	10 Nos
3.	Hot Plate	02 Sets
4.	Carpet looms (HK, HT, Dhurry, Pit)	01 each
5.	Tool Kit	20 sets
6.	Weighing balance	01

## MODULE –14 (Certificate Level – II)

<b>NAME</b>	:	Spinning of woolen Carpet yarn
<b>SECTOR/ CODE</b>	:	<b>Carpet / CAR213</b>
<b>ENTRY QUALIFICATION</b>	:	Class 8 <sup>th</sup> Passed & & 14 years of age, MES on Hand spinning of woolen carpet yarn
<b>TERMINAL COMPETENCY</b>	:	After completion of the course the candidates would be able to produce woolen yarn
<b>DURATION</b>	:	240 hours
<b>CONTENT</b>	:	Spinning of woolen yarn

<b>Practical Competencies</b>	<b>Underpinning Knowledge (Theory)</b>
<ul style="list-style-type: none"> <li>• Identification of various tools &amp; equipment &amp; material.</li> <li>• Safe working practices.</li> <li>• Identification of wool Fibre</li> <li>• Operation of woolen spinning line</li> <li>• Operation of Semi-Worsted spinning line.</li> <li>• Production of woolen yarn (s) of desired counts</li> <li>• Production of semi worsted yarn (s) of desired counts</li> <li>• Measurement &amp; control of Count &amp; Twist</li> <li>• Measurement &amp; control of yarn realisation</li> <li>• Practice Do's &amp; Don'ts</li> </ul>	<ul style="list-style-type: none"> <li>• Study of wool fibre</li> <li>• Study of sequence of operation of woolen spinning line</li> <li>• Study of the different machine setting parameters</li> <li>• Study of different product setting parameters</li> <li>• Study on yarn realisation</li> <li>• Do's &amp; Don'ts</li> </ul>

### **TOOLS AND EQUIPMENT FOR A BATCH OF 20 TRAINEES**

<b>S. NO.</b>	<b>DESCRIPTION</b>	<b>QUANTITY</b>
1.	Calulator, Scale, Tape, Weighing Balance	01 piece each
2.	Inside and outside calipers	01 piece each
3.	Tachometer	01 set each
4.	Gauges (for card, gill box, Rubbing Frame, R/F)	01 set each
5.	Count & Twist Measurement equipment for woolen yarn	01 set each
6.	Woolen Spinning line	01
7.	Semi worsted spinning line	01

## **MODULE –15 (Certificate Level – II)**

<b>NAME</b>	:	Spinning of Cotton Carpet Yarn
<b>SECTOR/ CODE</b>	:	<b>Carpet/ CAR215</b>
<b>ENTRY QUALIFICATION</b>	:	Class 10 <sup>th</sup> Passed & & 14 years of age, MES on Hand spinning of Cotton carpet yarn
<b>TERMINAL COMPETENCY</b>	:	After completion of the course the candidates would be able to produce cotton yarn
<b>DURATION</b>	:	240 hours
<b>CONTENT</b>	:	Spinning of Cotton Yarns

<b>Practical Competencies</b>	<b>Underpinning Knowledge (Theory)</b>
<ul style="list-style-type: none"><li>• Identification of various tools &amp; equipment &amp; material.</li><li>• Safe working practices.</li><li>• Identification of cotton Fibre</li><li>• Operation of cotton spinning line</li><li>• Production of cotton yarn (s) of desired counts</li><li>• Measurement &amp; control of Count &amp; Twist of cotton yarn</li><li>• Measurement &amp; control of yarn realisation</li><li>• Practice Do's &amp; Don'ts</li></ul>	<ul style="list-style-type: none"><li>• Study of wool fibre</li><li>• Study of sequence of operation of cotton spinning line</li><li>• Study of the different machine setting parameters</li><li>• Study of different product setting parameters</li><li>• Study on yarn realisation</li><li>• Do's &amp; Don'ts.</li></ul>

### **TOOLS AND EQUIPMENT FOR A BATCH OF 20 TRAINEES**

<b>S. NO.</b>	<b>DESCRIPTION</b>	<b>QUANTITY</b>
1.	Gauges (For card, draw frame, Spindle Frame, Ring Frame.	01 set each
2.	Calculator, Scale, Tape	01 piece each
3.	Inside & Outside Calipers	01 piece each
4.	Tachometer	01 set
5.	Count & Twist Measurement equipment of cotton yarn	01 set each
6.	Spinning Line	01

## MODULE – 16 (Certificate Level – II)

<b>NAME</b>	:	Carpet backing
<b>SECTOR/ CODE</b>	:	<b>Carpet / CAR216</b>
<b>ENTRY QUALIFICATION</b>	:	Class 10 <sup>th</sup> & & 14 years of age, MES Module on one of the following: <ul style="list-style-type: none"> <li>• Hand tufted carpet manufacturing</li> <li>• Broad loom carpet manufacturing</li> </ul>
<b>TERMINAL COMPETENCY</b>	:	After completion of the course the trained person would be able to do the backing of tufted carpets.
<b>DURATION</b>	:	240 hours
<b>CONTENT</b>	:	Carpet backing

<b>Practical Competencies</b>	<b>Underpinning Knowledge (Theory)</b>
<ul style="list-style-type: none"> <li>• Identification of various tools &amp; equipment &amp; material.</li> <li>• Safe working practices.</li> <li>• Analysis of latex and/or adhesive material</li> <li>• Analysis of backing fabrics</li> <li>• Measurement &amp; Monitoring of drying and adhesion</li> <li>• Setting of backing process</li> <li>• Testing for delamination &amp; tuft withdrawal force</li> </ul>	<ul style="list-style-type: none"> <li>• Study of sequence of operations</li> <li>• Study of backing materials including latex and/ or adhesive materials</li> <li>• Study of overall backing system including quality assurance</li> </ul>

### TOOLS AND EQUIPMENT FOR A BATCH OF 20 TRAINEES

<b>S. NO.</b>	<b>DESCRIPTION</b>	<b>QUANTITY</b>
1	Carpet backing system	05
2	Brush	20
3	Scraper	20
4	Testing kit	01
5	Tensile Tester	01
6	Tuft Withdrawal Tensometer	01
7	Moisture Meter	01

## MODULE – 17 (Certificate Level – II)

<b>NAME</b>	<b>:</b>	Carpet yarn dyeing with Natural Dyes
<b>SECTOR/ CODE</b>	<b>:</b>	<b>Carpet/ CAR217</b>
<b>ENTRY QUALIFICATION</b>	<b>:</b>	Class 10 <sup>th</sup> & & 14 years of age, MES module on carpet yarn dyeing
<b>TERMINAL COMPETENCY</b>	<b>:</b>	After completion of the course the trained person would be able to extract and dye Natural dyes on wool/silk/Art. Silk yarns.
<b>DURATION</b>	<b>:</b>	120 hours
<b>CONTENT</b>	<b>:</b>	Natural dyes: extraction procedure & dyeing on Carpet Yarn (Wool/ Silk/art silk) Dyeing

<b>Practical Competencies</b>	<b>Underpinning Knowledge (Theory)</b>
<ul style="list-style-type: none"> <li>• Identification of various tools &amp; equipment &amp; material.</li> <li>• Safe working practices.</li> <li>• Collection of harvested Raw materials for extraction of Natural dyes.</li> <li>• Practice of Extraction of dyestuffs from various harvested raw materials</li> <li>• Measurement and control of dye concentration, pH of extracted dye.</li> <li>• Dyeing of wool with extracted natural dyes</li> <li>• Dyeing of silk with extracted natural dyes</li> <li>• Dyeing of Art. Silk with extracted natural dyes</li> <li>• Control of parameters to obtain reproducible shades.</li> <li>• Testing of Colour Fastness</li> </ul>	<ul style="list-style-type: none"> <li>• Study of Fibres: Wool/silk/art. Silk</li> <li>• Study on availability of harvested Raw materials for extraction of Natural dyes.</li> <li>• Sequence of Natural dye extraction</li> <li>• Theory of dyeing with natural dyes</li> <li>• Importance of mordants &amp; auxiliaries.</li> <li>• Study on fastness properties of natural dyes</li> </ul>

### **TOOLS AND EQUIPMENT FOR A BATCH OF 20 TRAINEES**

<b>S. NO.</b>	<b>DESCRIPTION</b>	<b>QUANTITY</b>
1.	05 Kgs. Cabinet type dyeing machine	01
2.	S. S. Vessels (03 litres)	20 Nos
3.	Heating arrangements	10 Set
4.	Grinder	01
5.	Crockmeter	01
6.	Launderometer	01
7.	Xenotester	01

## MODULE – 18 (Certificate Level – II)

<b>NAME</b>	:	Carpet Finishing - II
<b>SECTOR/ CODE</b>	:	<b>Carpet / CAR218</b>
<b>ENTRY QUALIFICATION</b>	:	Class 10 <sup>th</sup> & & 14 years of age, MES module on Carpet Finishing-I
<b>TERMINAL COMPETENCY</b>	:	After completion of the course the trained person would be able to do the finishing of carpets.
<b>DURATION</b>	:	240 hours
<b>CONTENT</b>	:	Carpet finishing

<b>Practical Competencies</b>	<b>Underpinning Knowledge (Theory)</b>
<ul style="list-style-type: none"><li>• Identification of various tools &amp; equipment &amp; material.</li><li>• Safe working practices.</li></ul> <p>Practice for</p> <ul style="list-style-type: none"><li>• Singeing</li><li>• Shearing</li><li>• Stretching</li><li>• Sorting</li><li>• Clipping</li><li>• Carving</li><li>• Embossing</li><li>• Binding</li><li>• Colour cut</li><li>• Packaging</li></ul>	<ul style="list-style-type: none"><li>• Study of sequence of operations</li><li>• Study of finishing methods relevant to type of carpets</li><li>• Basics of packaging of carpets</li></ul>

### **TOOLS AND EQUIPMENT FOR A BATCH OF 20 TRAINEES**

<b>S. NO.</b>	<b>DESCRIPTION</b>	<b>QUANTITY</b>
1	Shearing machines	10
2	Frames	10 sets
3	Needles	
4	Embossing scissors	
5	Carving scissors	
6	Gas Torch	

## **MODULE – 19 (Certificate Level – II)**

<b>NAME</b>	:	Designing of fabric related to Carpet
<b>SECTOR/ CODE</b>	:	<b>Carpet/ CAR219</b>
<b>ENTRY QUALIFICATION</b>	:	Class 10 <sup>th</sup> & 14 years of age, MES module on Fabric Manufacture(CAR112)
<b>TERMINAL COMPETENCY</b>	:	The participants will be able to develop the fabric design for specified end use.
<b>DURATION</b>	:	360 hours
<b>CONTENT</b>	:	Fabric Woven Design

<b>Practical Competencies</b>	<b>Underpinning Knowledge (Theory)</b>
<ul style="list-style-type: none"><li>• Identification of various tools &amp; equipment &amp; material.</li><li>• Safe working practices.</li><li>• Development of dobby and Jacquard with respect to design.</li><li>• Drawing &amp; Drafting</li><li>• Pegging of lattice</li><li>• Card punching</li><li>• Dobby/ Jacquard design development</li></ul>	<ul style="list-style-type: none"><li>• Study of Basics of fabric structure</li><li>• Types of fabric for various end uses.</li><li>• Basics of Cloth setting</li><li>• Trend of design in backing fabrics related to carpet/ home textiles</li><li>• Basics of weaving process</li><li>• Study of dobby and Jacquard with respect to design.</li></ul>

### **TOOLS AND EQUIPMENT FOR A BATCH OF 20 TRAINEES**

<b>S. NO.</b>	<b>DESCRIPTION</b>	<b>QUANTITY</b>
1.	Card Punching Machine	02
2.	Loom with dobby & jacquard	01 each
3.	Dobby Lattices	20
4.	Pegs	1000

### **MODULE – 20 (Certificate Level – III)**

<b>NAME</b>	:	Modern Carpet Yarn Manufacturing
<b>SECTOR/ CODE</b>	:	<b>Carpet/ CAR320</b>
<b>ENTRY QUALIFICATION</b>	:	Class 10 <sup>th</sup> & & 14 years of age, MES module any one of following: <ul style="list-style-type: none"> <li>• Spinning of cotton yarn</li> <li>• Spinning of woolen yarn</li> </ul>
<b>TERMINAL COMPETENCY</b>	:	After the completion of course the participants will be able to handle the modern spinning machine like Dref to produce yarn as per desired quality.
<b>DURATION</b>	:	120 hours
<b>CONTENT</b>	:	Woolen Yarn Spinning on Dref or such Machine

<b>Practical Competencies</b>	<b>Underpinning Knowledge (Theory)</b>
<ul style="list-style-type: none"> <li>• Identification of various tools &amp; equipment &amp; material.</li> <li>• Safe working practices.</li> <li>• Identification of different parts of DREF 2000 or such machine</li> <li>• Setting of process &amp; machine parameter involved.</li> <li>• Practice to produce woolen or such yarn in DREF 2000 or such machine</li> <li>• Measurement &amp; Control of Count of Yarn</li> </ul>	<ul style="list-style-type: none"> <li>• Fibres and its uses</li> <li>• Types of fibres including wool fibre required for DREF machine</li> <li>• Sequence of operation in DREF or such Technology</li> <li>• Technique of manufacturing yarn through DREF or such machine</li> <li>• Do's &amp; Dont's</li> </ul>

#### **TOOLS AND EQUIPMENT FOR A BATCH OF 20 TRAINEES**

<b>S. NO.</b>	<b>DESCRIPTION</b>	<b>QUANTITY</b>
1.	Calulator	01 set
2.	Wrap Reel	01 set
3.	Weighing Balance	01 set
4.	Pick Glass	02 sets
5.	Microscope	01 set
6.	DREF or such Machine	01 set
7.	Stroboscope	01 set



## MODULE – 21 (Certificate Level – II)

<b>NAME</b>	: Carpet Designing CAD
<b>SECTOR/ CODE</b>	: <b>Carpet/ CAR221</b>
<b>ENTRY QUALIFICATION</b>	: Class 10 & any one MES module of level-I
<b>TERMINAL COMPETENCY</b>	: Ability to develop design primarily and convert the same in CAD environment
<b>DURATION</b>	: 240 hours
<b>CONTENT</b>	: Colour Theory, Textile & Carpet Design, CAD

PRACTICAL COMPETENCY	UNDERPINNING KNOWLEDGE (THEORY)
<ul style="list-style-type: none"> <li>• Development of Colour wheel</li> <li>• Use of crayons, colour pencil, Sketch &amp; water colour, poster colour</li> <li>• To create different type &amp; style design plate in these areas: ./ Textile: Jamdani, Phulkari, Kantha, Paithani, Banaras ./ Carpet: Kirman, Herati, Tabriz, Prayer Rug, Mir, Tufted and Modern Carpet Design</li> <li>• System Practice on CAD out of above mentioned creations</li> <li>• Exhibition of developed design for market testing</li> </ul>	<ul style="list-style-type: none"> <li>• To study historical aspects &amp; colour themes involved in areas ./ Textile: Jamdani, Phulkari, Kantha, Paithani, Banarasi ./ Carpet: Kirman, Herati, Tabriz, Prayer Rug, Mir, Tufted and Modern</li> </ul> <p style="text-align: center;">CAD</p> <ul style="list-style-type: none"> <li>• Different tools of CAD Software &amp; its Application for Textile &amp; Carpet Designing</li> <li>• Study of Colour, Motif &amp; Market trend</li> </ul>

### TOOLS AND EQUIPMENT FOR A BATCH OF 20 TRAINEES

S. NO.	DESCRIPTION	QUANTITY
1.	Table with Drawer	20
2.	Table for computer	10
3.	Chairs	40
4.	Computer with software	10

## MODULE – 22 (Certificate Level – II)

<b>NAME</b>	: Fundamentals of I. T. & its application in Carpet Industry
<b>SECTOR /CODE</b>	: <b>Carpet / CAR222</b>
<b>ENTRY QUALIFICATION</b>	: Class 10 / MES Module on Computer Fundamentals, MS- Office & Internet(ICT101)
<b>TERMINAL COMPETENCY</b>	: After doing the course the candidates would be able to use the computer /I.T. for Carpet & Textile Sector, for MIS, cost calculation etc.
<b>DURATION</b>	: 240 hours
<b>CONTENT</b>	: All Basic/Fundamentals of CS/IT

<b>PRACTICAL COMPETENCY</b>	<b>UNDERPINNING KNOWLEDGE (THEORY)</b>
<ul style="list-style-type: none"><li>• Practical of Basic Command/ Functions/ Statements for computer operation.</li><li>• Basic/ Some other relevant software practice.</li><li>• Practical for developing small programme for computation relevant to Carpet &amp; Textile</li><li>• Practical for Cost Calculation</li><li>• Practical for MIS reporting</li><li>• Cost output using Carpcost</li></ul>	<ul style="list-style-type: none"><li>• Basics of Information Technology</li><li>• Commands/ Functions of a particular programming language C++/Visual Basic</li><li>• Web technology, HTML, Protocols, HTTP, www</li><li>• Basics of networking</li><li>• Use of Software (Carpcost)</li></ul>

### **TOOLS AND EQUIPMENT FOR A BATCH OF 20 TRAINEES**

<b>S. NO.</b>	<b>DESCRIPTION</b>	<b>QUANTITY</b>
1.	Computer System	20
2.	Printer	01 Dotmatrix, 01 Inkjet
3.	Scanner	01
4.	Carpcost Software	01
5.	Calculator	01

## List of Expert/ Trade Committee Members

### CURRICULUM DEVELOPMENT FOR SHORT TERM COURSES BASED ON MODULAR EMPLOYABLE SKILLS

SECTOR/ AREA: **Carpet**

S. No.	Name, Designation & Organization	
1.	Prof. (Dr) K. K. Goswami, Director, IICT	Chairman
2.	Shri P. K. Bhar, Asstt. Professor & Registrar I/c.	Member
3.	Shri R. K. Malik, Asstt. Professor	Member
4.	Shri Rajesh Gupta, Asstt. Professor	Member
5.	Smt. Betty Dasgupta, Lecturer	Member
6.	Shri Anu Mishra, Lecturer	Member
7.	Shri B. C. Ray, Workshop In-charge	Member
8.	Shri M. A. Ansari, CTO	Member
9.	Shri G. N. Khatry, CTO	Member
10.	Shri R. N. Tripathi, CTO	Member
11.	Shri A. S. Sidhu, Senior Consultant Sahara India Bhawan 1, Kapoorthala Complex, Lucknow – 226 024	Member
12.	Shri Pramod Chand Pandey, In charge Marketing DSMS, DRDA, SRN, Bhadohi	Member
13.	Shri Avinash Chand Baranwal, Hon. Secretary All India Carpet Manufacturers Association, Bhadohi	Member
14.	Shri Ajay Kabra, Hon. General Secretary All India Carpet Yarn Spinner & Dealer Association, Bhadohi	Member
15.	Shri Zainul Abdin Beg, Member National Level Steering Committee, Carpet Export Promotion Council, New Delhi	Member

5B

DRAFT CURRICULUM  
M.TECH.(CARPET & TEXTILES)

**INDIAN INSTITUTE OF CARPET TECHNOLOGY (IICT), BHADOHI Affiliated to  
Dr. APJ ABDUL KALAM TECHNICAL UNIVERSITY, LUCKNOW PROPOSESD  
DRAFT TEMPLATE**

**OF**

**SCHEME OF EXAMINATION AND EVALUATION**

**ON**

**CHOICE BASED CREDIT SYSTEM**

**FOR**

**POST GRADUATE COURSE: M. TECH IN TECHNOLOGY MANAGEMENT (CARPET  
AND TEXTILE)**

**BY**

**(D.K BANWET)**

Ex.-Emeritus Prof,  
DMS, IITD

**(R. CHATTO PADHYAY)**

Prof. TTD,IITD

**(K.K GOSWAMI)**

Prof. & Director, IICT

**TO BE PLACED BEFORE BOARD OF STUDIES, A.K.T.U FOR ADOPTION**

The proposed M. Tech program endeavors to provide the students, a knowledge base of interdisciplinary theories and techniques, related to technology and its management to develop the students' decision-making and leadership capabilities to meet the stake holder's requirement. Further the structure of the course is so designed to train and develop students' terminal competency for career development and confidently face the challenges of a dynamic textile business including carpet world staged with diverse, multicultural and global business settings.

Towards these objectives and to suit the contents of each course, a variety of teaching methodologies, such as inter firm comparison in technology context case studies, role-play, problem solving exercises, group discussion, computer simulation games, audio-visuals, are used in the program.

### **Program Educational Objectives**

This M. Tech program seeks to enable students to achieve the following objectives:

1. To provide students with an unique foundation by making them aware of critical concepts, techniques & technologies that are relevant to achieving organisational objectives in Technology management perspective
2. To integrate the knowledge and skills thus acquired across various business functions in general and carpet textiles in particular.
3. Develop and strengthen various professional skills such as team building, leadership, effective communication & presentation skills to better negotiate the potential complexities in organizations in managing technologies..
4. Critically analyze and adopt a creative thinking approach to provide ethical, innovative and credible solutions, using information technology to ensure an immediate return on corporate investment, demographic dividend considering Socio economic Potential in carpet & Textile trade.
5. Students will demonstrate their ability to adapt to a rapidly changing environment and use this ability as input to propose strategies for future improvement.
6. Students will learn to assess & evaluate Technology & business issues and practices from a local and global perspective.
7. To ensure the smooth transition from campus to corporate by developing industry ready professionals. Who can combine two engines Technology & economy and art and craft.

### **Structure of Post Graduate Program**

The course is of two years divided into four semesters, in I year (I and II semester) will have eight compulsory papers of 40 sessions each of one hour duration. In II year (III & IV semester) will have 2 compulsory subjects each. The program offers a system of major and

minor specialisation having six papers (three each in III & IV semester) from major specialization & four papers (two each in III & IV semester) from minor specialization.

Summer training for 6 -8 weeks is compulsory for every student pursuing the course, which they have to undergo between second and third semester. Professional Proficiency Score, Comprehensive Viva and Research Project are part of the course.

### **Core Courses**

The students are required to complete the core courses as these are designed to give the students a firm base in the areas of General Management, Economics, Finance, Human Resource Management, Marketing, Information Technology Strategy, Entrepreneurship, International Business.

### **Elective Papers**

The M. Tech program to offer specialization in the areas of Advance in Carpet and Textile Technology, Advance in Designing Technology, Emerging Technology, international business focusing H.S. codes, operational management focusing performance metrics socio economics, Technology management ,international business, operation management, performance management.

A student is required to choose from elective papers for major and minor specialization as per scheme of AKT University.

### **Professional Proficiency Score**

The Professional Proficiency Score (PPS) would ensure the overall professional development in all area of Technology management like organizing, leadership, creativity and team building. This will include the contribution made by students in guest lecture, seminar, industrial visit, development of IT Skills & Soft Skills.

### **Comprehensive Viva**

The comprehensive viva voce will be scheduled as per scheme of AKT University.

### **Summer Training Project Report**

The student of M. Tech program to under go on the job training. The duration, objective, reporting , assessment, evaluation, presentation etc. will be finalised complying the need and scheme of the AKT university.

## **Research Project Report**

In fourth semester, the candidates will have to submit a Research Project report on a problem/topic (from the specialization areas) to be assigned by the department under the supervision of a core faculty member of the department. The research project report will be as per scheme /guideline of AKT University.



**TEMPLATE OF COURSE STRUCTURE FOR M. TECH IN TECHNOLOGY MANAGEMENT  
(C.T.M) PROGRAM**

Management foundation course to manage utilization of technology in industry.

**Semester I**

<b>S. No.</b>	<b>Course Title</b>	<b>Subject Area</b>	<b>Credit</b>
1	Organisation Behaviour (I)	General Management	4
2	Managerial Economics	General Management	4
3	Financial Accounting for Managers	Finance	4
4	Business Statistics	General Management	4
5	Business Environment	General Management	4
6	Marketing Management	Marketing	4
7	Business Communication	General Management	4
8	Computer Application & Management Information System	IT	4
9	Professional Proficiency Score		2
10	Comprehensive Viva		2
	<b>TOTAL</b>		<b>36</b>

**Semester II**

<b>S. No.</b>	<b>Course Title</b>	<b>Subject Area</b>	<b>Credit</b>
1	Organisational Behaviour (II)	General Management	4
2	Human Resource Management	HRM	4
3	Business Research Methods	General Management	4
4	Financial Management	Finance	4
5	Cost & Management Accounting	Finance	4
6	Production Operation & Supply Chain Management	General Management	4
7	Quantitative Techniques for Managers	General Management	4
8	Legal Aspects for Business	General Management	4
9	Professional Proficiency Score		2
10	Comprehensive Viva		2
	<b>TOTAL</b>		<b>36</b>

**Semester III**

S. No.	Course Title	Subject Area	Credit
1	Strategic Management	General Management	4
2	International Business Management	General Management	4
3	Specialization Group -1 Elective 1*		4
4	Specialization Group -1 Elective 2*		4
5	Specialization Group -1 Elective 3*		4
6	Specialization Group -2 Elective 1*		4
7	Specialization Group -2 Elective 2*		4
8	Professional Proficiency Score		2
9	Summer Training Project Report & Viva Voce		4
10	** Human Value & Professional Ethics/ Cyber Security		Non credit course
	<b>TOTAL</b>		<b>34</b>

**Semester IV**

S. No.	Course Title	Subject Area	Credit
1	Corporate Governance and Values and Ethics	General Management	4
2	Entrepreneurship Development	General Management	4
3	Specialization Group -1 Elective 3*		4
4	Specialization Group -1 Elective 4*		4
5	Specialization Group -1 Elective 5*		4
6	Specialization Group -2 Elective 3*		4
7	Specialization Group -2 Elective 4*		4
8	Professional Proficiency Score		2
9	Dissertation Project and Viva Voce		4
10	** Human Value & Professional Ethics/ Cyber Security		Non credit course
	<b>TOTAL</b>		<b>34</b>

Note: elective papers to be chosen out of list of proposed elective papers available.

## **ELECTIVES PAPERS**

### **Specialization Group: Human Resource**

#### **Electives Papers in III Semester**

<b>S. No</b>	<b>Course Title</b>
1	Recruitment & Selection
2	Training & Development
3	Compensation Management
4	Employee Relations & Labor Laws

#### **Electives Papers in IV Semester**

<b>S. No</b>	<b>Course Title</b>
1	Performance Management System
2	Negotiation & Conflict Management
3	International Human Resource Management
4	Organization Structure & Design

### **Specialisation Group: Marketing**

#### **Electives Papers in III Semester**

<b>S. No</b>	<b>Course Title</b>
1	Consumer Behaviour
2	Product & Brand Management
3	Digital Marketing
4	Integrated Marketing Communication

#### **Electives Papers in IV Semester**

<b>S. No</b>	<b>Course Title</b>
1	Marketing of Services
2	Retail Management
3	Sales & Distribution Management
4	Production cost analysis: Carpet & Textile

**Specialisation Group Finance: Sustainable Technology and management  
Electives Papers in III Semester**

<b>S. No</b>	<b>Course Title</b>
1	Industrial Manufacturing Process: Quality-Cost
2	Financial Management
3	Productivity & Management : Carpet & Textile
4	Technology Updates: Carpet & Textiles

**Electives Papers in IV Semester**

<b>S. No</b>	<b>Course Title</b>
1	Micro Finance
2	Working Capital Management
3	Tax Planning & Management
4	Project Management

**Specialisation Group: International trade**

**Electives Papers in III Semester**

<b>S. No</b>	<b>Course Title</b>
1	International Marketing
2	Indian Foreign Trade Framework
3	Export Import Documentation
4	WTO & Regional Trading Blocks

**Electives Papers in IV Semester**

<b>S. No</b>	<b>Course Title</b>
<b>1</b>	<b>International Business Strategy</b>
2	Designing Technology: Carpet & Textile
3	Focusing Market & trend: Carpet & Textile
4	Managing Cultural Diversity

## Specialisation Group: Information Management

### Electives Papers in III Semester

<b>S. No</b>	<b>Course Title</b>
1	Market intelligence: Carpet & Textiles
2	Web Technology
3	Database Management System
4	System Analysis & Design

### Electives Papers in IV Semester

<b>S. No</b>	<b>Course Title</b>
1	Managing IT Infrastructure
2	Management of unit value realisation: Carpet & Textile
3	Data Communication & Network
4	<b>Production Management: Business process out sourcing</b>

## SCHEME OF TEACHING AND EXAMINATION

### 1. Semester wise scheme of teaching and examination for semester I & II may be as under

#### Semester I

S. No.	Course Title	Credit	Hrs	Evaluation Scheme			
				Sessional Exams		Ext	Total
				Test	Assig/Att		
1	Organisation Behaviour (I)	4	40	20	10	70	100
2	Managerial Economics	4	40	20	10	70	100
3	Financial Accounting for Managers	4	40	20	10	70	100
4	Business Statistics	4	40	20	10	70	100
5	Business Environment	4	40	20	10	70	100
6	Marketing Management	4	40	20	10	70	100
7	Business Communication	4	40	20	10	70	100
8	Computer Application & Management Information System	4	40	20	10	70	100
9	Professional Proficiency Score	2			50		50
10	Comprehensive Viva	2				50	50
	<b>TOTAL</b>	<b>36</b>	<b>320</b>				<b>900</b>

#### Semester II

S. No.	Course Title	Credit	Hrs	Evaluation Scheme			
				Sessional Exams		Ext	Total
				Test	Assig/Att		
1	Organisational Behaviour (II)	4	40	20	10	70	100
2	Human Resource Management	4	40	20	10	70	100
3	Business Research Methods	4	40	20	10	70	100
4	Financial Management	4	40	20	10	70	100
5	Cost & Management Accounting	4	40	20	10	70	100
6	Production Operation & Supply Chain Management	4	40	20	10	70	100
7	Quantitative Techniques for Managers	4	40	20	10	70	100
8	Legal Aspects for Business	4	40	20	10	70	100
9	Professional Proficiency Score	2			50		50
10	Comprehensive Viva	2				50	50
	<b>TOTAL</b>	<b>36</b>	<b>320</b>				<b>900</b>

**2. Semester wise scheme of teaching and examination for semester I & II may be as under**

**Semester III**

S. No.	Course Title	Credit	Hrs	Evaluation Scheme			
				Sessional Exams		Ext	Total
				Test	Assig/Att		
1	Strategic Management	4	40	20	10	70	100
2	International Business Management	4	40	20	10	70	100
3	Specialization Group -1 Elective 1*	4	40	20	10	70	100
4	Specialization Group -1 Elective 2*	4	40	20	10	70	100
5	Specialization Group -1 Elective 3*	4	40	20	10	70	100
6	Specialization Group -2 Elective 1*	4	40	20	10	70	100
7	Specialization Group -2 Elective 2*	4	40	20	10	70	100
8	Professional Proficiency Score	2			50		50
9	Summer Training Project Report & Viva Voce	4			50	100	150
10	** Human Value & Professional Ethics/ Cyber Security	Non credit course	20	20	10	70	100
<b>TOTAL</b>		<b>34</b>	<b>300</b>				<b>1000</b>

**Semester IV**

S. No.	Course Title	Credit	Hrs	Evaluation Scheme			
				Sessional Exams		Ext	Total
				Test	Assig/Att		
1	Corporate Governance and Values and Ethics	4	40	20	10	70	100
2	Entrepreneurship Development	4	40	20	10	70	100
3	Specialization Group -1 Elective 3*	4	40	20	10	70	100
4	Specialization Group -1 Elective 4*	4	40	20	10	70	100
5	Specialization Group -1 Elective 5*	4	40	20	10	70	100
6	Specialization Group -2 Elective 3*	4	40	20	10	70	100
7	Specialization Group -2 Elective 4*	4	40	20	10	70	100
8	Professional Proficiency Score	2			50		50
9	Dissertation Project and Viva Voce	4				150	150
10	** Human Value & Professional Ethics/ Cyber Security	Non credit course	20	20	10	70	100
<b>TOTAL</b>		<b>34</b>	<b>300</b>				<b>1000</b>

**DRAFT PROPOSAL**  
**RULES AND REGULATIONS**  
**FOR**  
**POST GRADUATE PROGRAM M. TECH IN TECHNOLOGY MANAGEMENT**  
**(CARPET & TEXTILE)**

**CHOICE BASED CREDIT SYSTEM (CBCS):**



The CBCS provides choice for student to select from prescribed courses. Sequencing Plan for the M. Tech in technology management Curriculum

<b>Semester</b>	<b>Course Coverage</b>
<b>I &amp; II</b>	<b>Core Courses</b>
<b>III &amp; IV</b>	<b>Core Courses &amp; Electives</b>

## **1. Admission**

**1.1** Admission to M. Tech first year in Ist semester is proposed to be in the line of IIT's/NIT's. The decision of central govt. and subsequent approval of affiliating University- Dr. A. P. J. Abdul Kalam Technical University (APJAKTU) Lucknow is applicable.

**1.2** Admission on migration of a candidate from any other University to the University Shall be permitted considering all India status of IICT.

## **2. ELIGIBILITY FOR ADMISSION**

### **2.1 Admission to M.TECH TECHNOLOGY MANAGEMENT (CARPET & TEXTILES) First Year through Entrance Examination:**

Candidates who have passed a B. Tech in Carpet & Textile Technology / equivalent qualification with at-least 65 percent marks (relaxation for SC/ST candidates of 5%) obtained after a minimum of four years of education after completing higher secondary schooling (10+2) or equivalent. GATE qualified candidates will get priority.

### **2.2 Direct Admission on Vacant seats at Institutions / College level:**

The eligibility criteria for direct admission on seats vacant in first year after entrance examination counseling shall be such as may be notified from time to time.

**2.3** The IICT authority shall have power to amend or repeal the eligibility criteria laid down at clause 2.1 as per the guidelines of Statuary body like affiliating university.

## **3. ATTENDANCE**

**3.1** Every student is required to attend all the lectures, tutorials, practical and other prescribed curriculum and co- curricular activities. The attendance can be condoned upto 25% on medical grounds or for other genuine reasons beyond the control of students.

**3.2** A further relaxation of attendance upto 15% for a student can be given provided that he/she has been absent with prior permission of the Head of Institution / College for the reasons acceptable to him.

**3.3** No student will be allowed to appear in the end semester examination if he/ sh\e do not satisfy the overall average attendance requirements of Clause no. 3.1 and 3.2 and such candidate(s) shall be treated as having failed and will be further governed by clause no 4.2 & 4.3.

**3.4** The attendance shall be counted from the date of admission in the college or start of academic session whichever is later.

#### **4. DURATION OF COURSES**

**4.1** Total duration of the M. Tech Course shall be 2 years, each year comprising of two semester. Each semester shall normally have teaching for the 90 working days or as prescribed by University from time to time.

**4.2** The student admitted to 1<sup>st</sup> year M. Tech shall complete the course within a period of four academic years from the date of first admission, failing which he/she has to discontinue the course.

**4.3** A candidate, who has failed twice in first year due to any reason (either due to his/ her non- appearance or he/ she being not permitted to appear in semester examinations) shall not be allowed to continue his/ her studies further. Provided further that if a student wishes to continue third time in first year he/she may be allowed on the terms and conditions laid down by the University for such permission but the maximum time allowed for completing the course will remain the same as in clause 4.2.

#### **5. CURRICULUM**

**5.1** The 2 year curriculum has been divided into 4 semesters and shall include lectures, tutorials, practical, seminars and projects etc, in addition to industrial training and educational tour etc. as defined in the scheme and executive instructions issued by the University from time to time.

**5.2** The curriculum will also include such other curricular , co – curricular and extra curricular activities as may be prescribed by the university from time to time.

#### **6. EXAMINATION**

**6.1** The performance of a student in a semester shall be evaluated through continuous class assessment and end semester examination. The continuous assessment shall be focused on class tests, assignment/tutorials, quizzes/viva voce and attendance. The marks for Continuous assessment (Sessional marks) shall be awarded at the end of the semester. The end semester examination shall be comprised of written papers ,

practical and viva voce, inspection of certified course work in classes, project work or by means of any combination of these methods.

**6.2** The distribution of marks for sessional, end semester theory papers, practical and other examinations, seminars, projects, industrial training and general efficiency shall be as prescribed.

**6.3** The marks obtained in a subject shall consists of marks allotted in end semester theory paper and sessional work.

**6.4** The marks of Professional Proficiency Score (PPS) shall be awarded by head of Institution / Department looking at overall assessment of participation in extra co curricular activities and discipline / sincerity/ behavior of student during entire semester.

## **7. ELIGIBILITY OF PASSING /PROMOTION AND ELIGIBILITY FOR THE EXAMINATION / CARRY OVER SYSTEM**

The ordinance /guideline of affiliating university- Dr. A. P. J. Abdul Kalam Technical University (APJAKTU) Lucknow are applicable.

## **8. RE-ADMISSION IN THE INSTITUTION/COLLEGE**

A candidate may be allowed for re- admission provided he/she satisfies one of the following conditions:

10.1 candidate is declared fail

10.2 A candidate did not appear in a semester examination/or he/she was not granted permission to appear in the examination

10.3 A candidate has been detained by the institute and subsequently has been permitted to take re admission

10.4 A candidate as an ex student passed the examination of the academic year or qualified for carry over system.

10.5 Candidate promoted with carry over subject and he/she opted for readmission.

## **9. COURSES**

**9.1** There will be two types of courses.

- Core Courses: This is the course which is to be compulsorily studies by a students as a core requirement to complete the requirement of a program in a said discipline of study.
- Elective Course: This is course which can be chosen from the pool of papers .It may be supportive to the discipline/domain /providing extended scope/enabling an exposure to some other discipline / domain/nurturing student proficiency skills.

**9.2** The minimum number of students to be registered for an elective to be offered shall be as per institute requirement to be duly approved by affiliating university- DR. A. P. J.

Abdul Kalam Technical University (APJAKTU) Lucknow is applicable.

**9.3** A Students shall exercise his option in respect of the elective and register for the same at the beginning of the concerned semester. The student may be permitted to opt for change of elective subject within 15 days from the date of commencement of the semester as per the calendar of the University.

**10. OTHERS: COMPUTATION OF SGPA AND CGPA/ CONVERSION OF GRADES INTO PERCENTAGE/ AWARD OF RANKS PRIZES AND MEDALS/SECURITY AND REVALUATION/ UNFAIR MEANNS /AWARD OF SESSIONAL MARKS AND PROFESSIONAL PROFICIENCY SCORE/ CANCLATION OF ADMISSION**

The System/scheme of Dr. APJAKT University, the affiliating university shall be binding for all above clauses.

Note: this is a draft proposal prepared by consultants and Director IICT and subject to any revision in due course of time before the same is adopted.

6

# CERTIFICATE

# Certificate

This is to certify that the report entitled “Feasibility Report on Upgradation of IICT, Bhadohi to a National Level Textile Institute of University Level”—A DPR in compliance to SFC/EFC stipulations submitted by IICT, has been prepared based on consultation /discussion with us from time to time. The co-operation and support extended by Director IICT as Project leader, Mr. K.K. Bajpai, Associate Professor, Management Faculty, School of Management Sciences, Varanasi and Dr. S.K. Pal, Professor, IICT as field experts is highly appreciated. Many documents pertaining to physical and financial progress reports, portfolio wise achievements , strategic directions of competent authorities, reference of VIP (Member of Parliament, Bhadohi) minutes of various review meetings including the preliminary DPR and direction by the then DC(HC) have been made available. Further, terms of reference (TOR) of the project proposal and subsequent TOR guided to focus our action point/deliverables in tune with the time frame enumerated in the road map. The SFC/EFC format dully filled in backed by various statements: physical, financial, statutory etc. were also seen and verified. The proposed financial cost estimates seems to be reasonable and justified considering the renderable service to the rural folk and potential demographic dividend. Interestingly the elements like fashion, advanced technical and design labs, advanced computation and I.T. labs, EDP cell etc. are novel and unique to strengthen the competency of the existing B. Tech and modular courses on one hand and proposed M.Tech. Curriculum in Technology Management in Carpet & Textiles and other emerging modular courses, including outreach activities on the other. This upgradation and successful execution may eventually pave the way for IICT to become a full-fledged Textile University in future. The proposed upgradation cost of Rs. 68.42 Cr (Non rec: Rs 54.24 Cr, Rec: Rs.14.18 Cr) to be executed over a period of 5 years seems reasonable.

In our considered opinion, it is too early to recommend the proposal for converting IICT to University status, as of now. Upgradation of facilities and faculties as proposed is recommended and should be executed over a period of five years. It is felt that the institute must strive to be well equipped with strong faculty resource which is evolutionary, more time consuming as compared to creating infrastructure capabilities of buildings, equipment etc. Thereafter, in the next phase it would seem more appropriate to pitch IICT to the level of a full-fledged university.

(Prof. D.K. Banwet)  
Emeritus Professor, DMS, IITD  
Vice Chancellor, UEM  
Kolkata

(Prof. R. Chattopadhyay)  
Professor, Textile Technology Dept.,  
IITD  
Ex-Prof I/C Planning, IITD

# 7

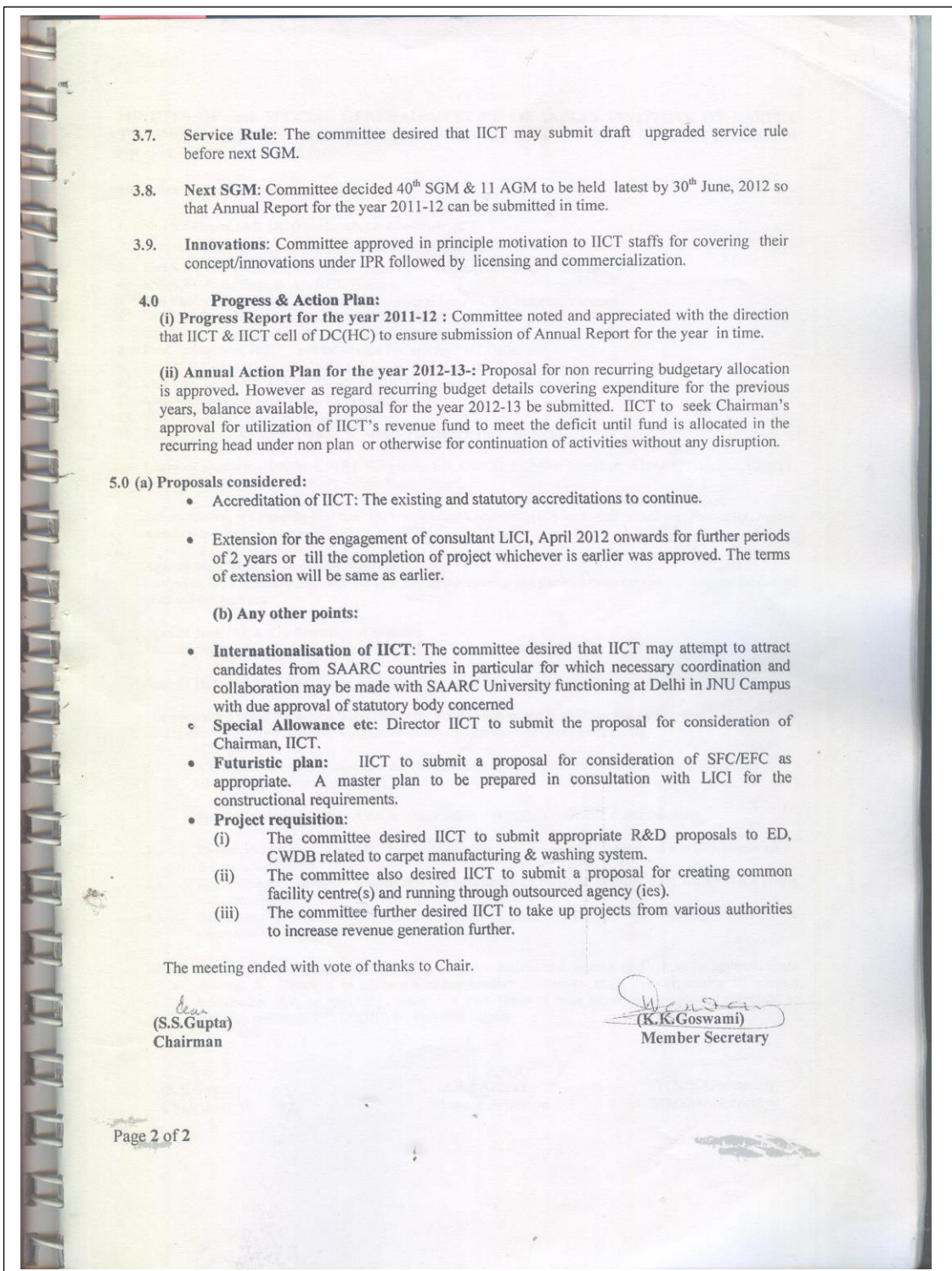

## ANNEXURES

## 7.1 Copy of EC resolution dated 19-3-2012



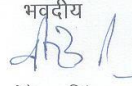
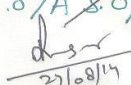

## 7.2 Reference of VIP – MP Dated 27-08-2014

<b>वीरेन्द्र सिंह</b> संसद सदस्य (लोक सभा)	 सांसद भवन	<b>आवास- स्वदेशी आश्रम</b> इन्दिरा मिल चौराहा, चौरी रोड, जनपद- सन्त रविदास नगर भदोही पिन - 221401, उत्तर प्रदेश मो0 नं0 09452105009
पत्रांक : 00089/78BDH/MP		दिनांक : 27 अगस्त 2014
आदरणीय, विकास आयुक्त हस्तशिल्प एवं अध्यक्ष आई.आई.सी.टी. भदोही कार्यालय विकास आयुक्त हस्तशिल्प पश्चिम खण्ड-7, आर.के. पुरम नई दिल्ली-110066		
विषय: राष्ट्रहित एवं जनहित में आई.आई.सी.टी. भदोही की उपयोगिता के सम्बन्ध में।		
<p>में हाल ही में आई.आई.सी.टी. भदोही में दौरा किया यहाँ पर स्थापित जो विश्वस्तरीय सुविधाएँ बनायी गयी वह बहुत ही सराहनीय हैं मैंने आई.आई.सी.टी. के अध्यापकों/अधिकारियों एवं स्टाफ तथा उद्योग जगत के लोगों से गहन बातचीत एवं आत्मनिरीक्षण के पश्चात् निम्न बातों का उल्लेख करना चाहता हूँ:-</p> <ol style="list-style-type: none"><li>1. आई.आई.सी.टी. का विस्तार किया जा सकता है।</li><li>2. आई.आई.सी.टी. का विस्तार डिम्ड विश्वविद्यालय के स्तर पर इण्डियन स्कूल ऑफ टेक्सटाईल के रूप में किया जाय।</li><li>3. इस विश्वविद्यालय में टेक्सटाईल के हर क्षेत्र के साथ-साथ कम्प्यूटर, विज्ञान प्रबन्धन के क्षेत्र का भी समावेश रहेगा जिससे इण्डियन स्कूल ऑफ टेक्सटाईल पूर्ण एवं प्रभावशाली तरीके से कार्य करेगा।</li><li>4. इसके अलावा सम्बन्धित क्षेत्र के सभी व्यवसायिक प्रशिक्षण की भी सुविधा आई.आई.सी.टी. भदोही में बनायी जाय जिससे अधिक से अधिक योग्य प्रशिक्षित व्यक्तियों को उद्योग जगत को दिया जाय।</li></ol> <p>अतः आपसे अपेक्षा की जाती है उपरोक्त विषय पर आप अपने सम्बन्धित अधिकारी को निर्देशित करें ताकि एक डी.पी.आर. (Detailed Project Report) आपके सक्षम आवश्यक कार्यवाही हेतु प्रस्तुत किया जाय तथा उसकी एक प्रति मुझे भी अग्रसारित किया जाय ताकि आगे की कार्यवाही हेतु माननीय वस्त्र मंत्री भारत सरकार से मिलकर आवश्यक कार्यवाही सुनिश्चित किया जाय। इस सम्बन्ध में हमारा पूरा सहयोग आवश्यकतानुसार समय-समय पर प्राप्त होता रहेगा।</p>		
		<b>भवदीय</b>  वीरेन्द्र सिंह सांसद भदोही
DATE: 22/10 DATE: 27/8/14		
H.O.O/A.S.O/A.O/ DMC (KS)  27/08/14		TO put up/whistle for me  27/8/14

7.3 Concept Note Director IICT submitted dated 03-03-2015

**INDIAN INSTITUTE OF CARPET TECHNOLOGY (IICT)  
CHAURI ROAD, BHADOHI-221 401**

**1/10/DMC/DIR/Gen/2015**

**Date: 03.03.2015**

**Note**

**Ref: Letter addressed to DC(HC), Ministry of Textiles, GOI by  
Hon'ble Member of Parliament(MP), Bhadohi-reg**

**Sub: Proposal for Conversion of IICT to Indian School of Textiles  
University-reg**

This refers letter of Honble MP, Bhadohi Shri Virendra Singh dated 27.08.2015 addressed to DC(HC), Chairman, IICT on the above mentioned subject (**enclosed-Annexure-I**)

In compliance to above the undersigned preferred to interact with all concerned and subsequently a road map on conversion of IICT to Indian School of Textiles University is drafted for perusal of Development Commissioner (Handicrafts),Chairman, IICT.

Subsequently, Hon'ble MP desired to follow up about reply of his letter and met Director (HC), Vice-Chairman, IICT and DC(HC), Chairman, IICT on 25.02.2015 and discussed the issue of conversion of IICT to a full fledged Textile University. The discussion emerged as under.

DC(HC) advised "Director, IICT to submit a concept note accordingly"

On the above background the concept note prepared is enclosed herewith for perusal and subsequent decision/action with the request to keep honble MP Bhadohi updated to avoid any communication gap.

[Prof(Dr) K K Goswami]  
Director & Member Secretary  
IICT, Bhadohi

Director (HC), Vice-Chairman, IICT

Development commissioner (HC), Chairman, IICT

## **DRAFT ROAD MAP FOR CONVERSION OF IICT TO INDIAN SCHOOL OF TEXTILE UNIVERSITY**

### **1.0 Introductory & Background Note:**

In meeting dated 25.02.2015 Hon'ble MP Shri Virednera Singh interacted personally with Director (HC), Vice-Chairman, IICT & DC(HC), Chairman, IICT in presence of undersigned.

*“It was opined to have a concept note on conversion of IICT to Textile University Prof. Dr. K K Goswami was assigned by Chairman, IICT for preparing the concept note for conversion of IICT to a Textile University”*

It was realized that University is for the development of Human being at large and the basic needs of human being are Roti (Food), Kapda (Textiles) and Maakan (Shelter). Thus there is a responsibility of any university in general and IICT a new and unique institute in particular to have course curriculum in Textiles of universal nature either as independent division and or as multidisciplinary approach integrating the need with other relevant/existing divisions. Statistics reveal as well it was pointed out by Hon'ble MP too that in this area proposed university should contribute and thus why not IICT to take lead in creating university departments for universal course on Textile Technology (Handicrafts high-tech, Agriculture to Medical) deriving demographic dividend. The country's largest youth population of the world at the same time largest unemployed youth pool why not be well utilized to arrest anticipated demographic disaster otherwise? Textile industry is one of the such technology related field where India can prepare and utilise its youth to cater not only National but also International demand of manpower in all level of skill sets. A Entrepreneur Development Cell (EDC) of unique type can be created for making youths including drop outs but having hidden talent to make them self reliant. The EDC can provide skill as well as linkage to financial institutes like NABARD etc in a manner that these youths can contribute to GDP of the country and eradication of poverty/population in below poverty line (BPL). Therefore, IICT may decide the portfolios in accordance in totality to take care of textile industry in providing human resources, research & development including design/process/product

diversification support in one hand and technical support and service as a direct linkage/bridge mechanism in other hand.

It is felt necessary to have a brief idea about Textile Industry vis a vis existing Textile Education in India. It is also necessary to point out why IICT, Bhadohi should take up establishment of universal courses on textile technology and in what way and how? These are the pre requisite information to understand the detailed road map (DRM) which follows.

## **2.0 ABOUT TEXTILE INDUSTRY AND TEXTILE EDUCATION:**

### **2.1 TEXTILE INDUSTRY:**

The market size of textile industry for the terminal year 11<sup>th</sup> plan (2012) has been as under

Exports : 55 US\$ Billion

Domestic: 60 US\$ Billion

Total: 115 US\$ billion

The assumed growth rate during the 11<sup>th</sup> plan was 16%. It indicates 'economic' status and importance of the textile industry:

The sector/industry can be segregated as under

#### **1. Core Textile Sector**

I Cotton/manmade fibre/yarn : Textile/Mill Sector including SSI, Spinning and exclusive weaving units.

II Manmade fabric/filament yarn including texurising industry.

III Decentralised powerlooms sector

IV Handloom Sector

V Knitting Sector

VI Processing Sector

VII Woolen sector

VIII Readymade Garment including knitwear sector

IX Sericulture

X Handicrafts Sector including Carpets

XI Jute Industry organized and decentralized

XII Technical Textile

#### **2. Allied Sector**

I Cotton : Agriculture, Ginning / pressing , Trade

II Sheep rearing

III Jute agriculture

IV Textile Machinery Industry and accessories

IICT, Bhadohi can plan to create portfolios in a manner that all parts of the core and allied sectors grow e.g., Fibre Technology, Spinning Processes, knitting & non woven, weaving, processing, Technical Textiles, Engineering related to cotton, wool & Silk.

**Sector wise estimated investment and direct manpower as per published report for 11<sup>th</sup> Five Year Plan (2007-2012).**

Sl No.	Sector	Investment (in crore)	Direct manpower requirement (in lakhs)
1	Spinning	50200	4.10
2	Weaving	20200	2.70
3	Knitting	2400	0.20
4	Processing	56000	1.50
5	Clothing	21800	56.50
	<b>Total</b>	<b>1,50,600</b>	<b>65.00*</b>

\*@ 10% estimated technical man power for which university and institutes are primarily responsible is 6.5 lakhs. Who will serve as indirect manpower securing U.G./P.G level Technical/management education related to gamut of textiles.

**2.2. TRADE STATISTIC ON TEXTILES:**

The analytical data on global trade for 2009 reveals following

- Global Trade (export + import) in \$ billion (558 + 536) is 1094.
- Indian Trade (export + import) in \$ billion (23 + 11) is 34.

The trend gives a fair idea about scope of Indian trade in global perspective and need of Textile Education simultaneously.

**2.3 ABOUT TEXTILE EDUCATION IN INDIA:**

Textile Education in India: A status report reveals following

There are around 36 (34 + 2) degree level textile institutes in which Centrally funded Technical institutes are

- Indian Institute of Technology, Delhi, New Delhi
- Dr. B.R.Ambedakar NIT, Jalandhar
- National Institute of Fashion Technology, New Delhi
- Indian Institute of Carpet Technology, Bhadohi UP

Only one IIT (Delhi) , one NIT (Jalandhar) and two specialized institute like NIFT (Delhi and its branches) and IICT (Bhadohi) are providing textile education in National and higher level. The annual Volume turn over by them is not sizeable as compared to required volume. No Textile University of the proposed kind is reported to be providing technical education in textile in such level.

Intervention by IICT,Bhadohi may be critical for enhancing the competitiveness of the industry in the globalised scenario.

**2.4 ABOUT TEXTILE EDUCATION IN GLOBAL LEVEL:**

The data base maybe created to facilitate catering the global gap which can be tapped by IICT in exporting human resources to derive demographic dividend as a policy.

### **3.0 WHY AND HOW IICT, BHADOHI TO ESTABLISH TEXTILE EDUCATION:**

#### **3.1 Why IICT should offer Universal Textile Education:**

- (i) One of prime requirement of humanity is Textiles. Therefore, the education/R&D in that faculty by this young institute should be offered subject to existence of envisaged demand.
- (ii) There is a scope for Ministry of Textiles through IICT to intervene to assist the textile economy as depicted above to meet the said gap in direct or indirect manpower requirement (to be verified) as deemed feasible.
- (iii) Better utilization of existing land resource available:  
The huge land available at Bhadohi can be acquired easily in public interest and be utilized for cultivation of vegetable fibres like cotton, jute, sisal, hemp etc, farming of sheep for wool, sericulture for silk, plantation for organic/natural colors like. These raw materials can be used for value added production in Textile Division-where students, researchers can work in an environment where production can take place in a manner that products are worthy for sale. A part of expenditure incurred thus simultaneously can be recovered.
- (iv) IICT can become the first Textile University of the country to take care of Textile Technology Education in a universal manner.
- (v) Being a Central funded Technical Institute, IICT can take all necessary precautions at the beginning if the project is decided to be launched.

#### **3.2 HOW IICT WOULD SERVE THE SECTOR?**

- ✓ By addressing the trained manpower needs of textiles and related segment including handicrafts, handloom, sericulture, jute, technical textiles covering eco textiles, organic textiles etc by developing a cohesive and integrated framework of training through portfolio like Human Resource Development (HRD) as mentioned later based on the industry needs.
- ✓ By increasing employability in wide range and level of skill sets required in various segments as mentioned above through strategic step(s).
- ✓ By simultaneously ensuring sufficient flexibility to meet the dynamic needs of the industrial sectors as a whole in general and textile sector in particular.
- ✓ IICT can create an exemplary trainers pool for the service of the Indian textile industry and global too as per policy framework.
- ✓ The portfolio of Design Creation and Development (DCD) at IICT can play critical role for some sectors like home Txtiles, Khadi, handloom, handicrafts and jute artisans too to help them produce diversified products

with innovative applications and improve quality meeting the changing market trends.

- ✓ Course on product Development: HS code specific skill & module(s) in International Textile Trade is elaborated below through reproduction of a published article (**Enclosed-Annexure-II**). The propose university may frame course work for UG/PG/other modular employable skill to boost the trade through deriving demographic dividend

**3.2.1 Suggested strategy:**

1. SWOT analysis for establishing the university be done at the beginning through appropriate survey.
2. Private Sector participation may be encouraged through PPP Model for setting up various departments of Textile Industries following success model available internationally.
3. The departments of Textile Technology Division would be demand driven based upon requirement of the industry.
4. To operate pilot project i.e. Phase III proposal in hand initially to experiment before full fledged university brought into operation.
5. The scheme be scaled up in certain pre decided years of time to meet the target.
6. The concept can be included in budget speech in next year’s (2016-17) budget provision.

**3.2.2 TARGETING EXPECTED IMPACT:**

1. IICT can create employable skill
2. Massive training by IICT to result massive employment
3. Diversified Skill development will cover from basic to advanced and emerging technology to result demographic dividend.

**4.0 Precised action points for deciding establishment of Textile University on TO R for consultant(1.0 to 3.0)**

<b><u>Activities</u></b>	<b><u>Responsibility &amp; Target Date</u></b>
4.1 Study on following and gathering statistics. (a) Indian Textile Industry - The statistics on trade (import and export) in value and volume term. - HS code wise statistics. - Data base on skill gap (b) Global Textile Industry - The statistics on trade (import and	<b>Responsibility with the Target Date may be fixed by DC(HC) or engaged consultant</b>

<p>export) in value and volume term.</p> <ul style="list-style-type: none"> <li>- HS code wise statistics.</li> <li>- Data base on skill gap</li> </ul> <p>(c) Textile Education /R&amp;D in India</p> <ul style="list-style-type: none"> <li>- Identification of gap and industry needs</li> </ul> <p>(d) Textile Education /R&amp;D in world</p> <ul style="list-style-type: none"> <li>➤ Identification of gap and industry needs</li> </ul> <p><b>*Note:</b> Following organizations may be contacted for collection/up gradation of statistics.</p> <p><b>For 1a and 1b</b></p> <ul style="list-style-type: none"> <li>✓ Ministry of Textiles(MOT)</li> <li>✓ Statistics wing of MOT</li> <li>✓ Ministry of Commerce and Industry (MOC&amp;I)</li> <li>✓ DGCIS, MOC&amp;I</li> <li>✓ Confederation of Indian Textile Industry (CITI)</li> <li>✓ Confederation of Indian Industry (CII)</li> <li>✓ Relevant International Bodies like International Trade Centre (ITC)</li> </ul> <p><b>For 1c &amp; 1d</b></p> <ul style="list-style-type: none"> <li>✓ Ministry of HRD (MHRD)</li> <li>✓ AICTE, MHRD</li> <li>✓ UGC, MHRD</li> <li>✓ IIT Delhi and NIT Jalandhar</li> <li>✓ TIFAC, Ministry of Sc. &amp; Tech</li> <li>✓ Relevant international bodies like The Textile Institute, Manchester, UK</li> </ul>	
<p><b>4.2 Conceive portfolios, however with International bench marking only as per guideline as under .</b></p> <p><b>4.2.1 <u>Human Resource Development (HRD)</u></b></p> <ul style="list-style-type: none"> <li>(a) Moduler short term: Certificate, Diploma</li> <li>(b) Modular long term: UG &amp; PG</li> <li>(c) Modular distance : Certificate, Diploma, UG &amp; PG</li> <li>(d) Modular on the job: Needbased</li> <li>(e) Entrepreneur Development Cell (EDC)</li> </ul>	



<p>4. <u>2.2 Research and Development (R&amp;D)</u></p> <ul style="list-style-type: none"> <li>(a) Product Development</li> <li>(b) Technology Upgradation.</li> <li>(c) Standardisation: (input-Process-Output)</li> <li>(d) Sponsored Projects</li> <li>(e) Reduction of drudgery of artisans: loom, processing and finishing devices.</li> <li>(f) Standardization of process: cost and quality</li> <li>(g) Process and product development: washing and printing system, Hi-tech-nano/ plasma/ phase change materials/ dry process in lieu of wet.</li> </ul> <p><u>4.2.3 Creation of Design and Development:</u></p> <ul style="list-style-type: none"> <li>a) Creation of Design</li> <li>b) Development of Design using CAD</li> <li>c) Bank of Motif/Design</li> </ul> <p><u>4. 2.4 Technical Service to Industry</u></p> <ul style="list-style-type: none"> <li>a) Sample Testing</li> <li>b) Certification of Product</li> <li>c) Trouble Shooting</li> <li>d) Technical &amp; Management Consultancy.</li> <li>e) Benchmarking through Inter Firm Comparison (IFC) and data banking.</li> <li>f) Market Intelligence Cell (MIC)</li> <li>g) Energy Conservation Cell (ECC)-energy audit, solar science etc.</li> </ul>	
<p><b>4.3 Analysis of 4.1 &amp; 4.2 to decide</b></p> <ul style="list-style-type: none"> <li>I. Whether IICT will take up the project in establishing University or not</li> <li>II. If yes, whether IICT will meet National or International demand.</li> <li>III. To decide <ul style="list-style-type: none"> <li>(a) In principle whether HRD, R&amp;D, DCD &amp; TSI all or any other combination to be launched.</li> <li>(b) About activities like whether (a) to (d) all or as other combination in HRD (4.2.1) and similarly for other</li> </ul> </li> </ul>	

portfolios (4.2.2, 4.2.3 & 4.2.4)	
<p><b>4.4 Demand/Gap Analysis:</b>  O/o DC(HC) through IICT to engage a consultant / professional in this regard as per concept in point 3 in respect of portfolios and required bench mark to identify demand/gap.  O/o DC(HC) to get demand/gap analyzed through a proper format, sampling technique and other appropriate tools and gadgets. The analysis to focus on pre decided portfolios / activities to be taken up as per policy of Ministry of Textile (MoT) in finding the demand / gap. The study to ensure degree of viability through expected return /impact on expected demand.  These information and some more in addition as adjudged by the professional during the course of analysis fulfills preparation of DRM. The compliance to DRM accumulating desired information will become the primary input for preparing Detailed Project Report (DPR)</p>	
<p><b>4.5 Final view on Creating portfolios &amp; activities as per 1-4 vis a vis policy.</b>  (i) Identify International level facilities to be created. (ii) Estimate tentative Investment for identified facilities and market trend. (iii) Policy on Investment in phased manner appropriately.  (iv) Output vs estimated investment in physical, financial, social etc.</p>	
<p><b>4.6 Detailed Project Report (DPR):</b>  After compliance to DRM as suggested above (4.1-4.5) a DPR to be in place. The undersigned may offer his guidance in preparing the DPR by the engaged experts/outside professional /consulting organization. The prima facie requirements for the DPR are as under</p> <ul style="list-style-type: none"> <li>➤ Verify information to be acquired as per DRM</li> <li>➤ Justify Portfolio(s) selection /creation</li> <li>➤ Selected portfolio wise identification of</li> </ul>	<b>Consultant</b>

<ul style="list-style-type: none"> <li>- Infrastructure and project planning (PERT/Activity Chart)</li> <li>- Manpower requirement and recruitment(Rule/Selection Process)</li> <li>- Expenditure projection (Salary , consumables, maintenance etc.).</li> <li>- Revenue Generation (Fees, service charges, consultancy, royalty, sales)</li> <li>➤ Training and Employment Cell</li> <li>➤ Entrepreneur Development Cell.</li> <li>➤ Market Intelligence Cell (MIC)</li> <li>➤ Energy Conservation Cell (ECC)</li> <li>➤ Market /Employment linkage (advance marketing of product)</li> <li>➤ Performance Measurement (Target Fixation in international perspective)</li> <li>➤ Performance Management (achievement and plan for removal of gap)</li> <li>➤ Self sustainability level ?</li> <li>➤ Self sustainability plan</li> <li>➤ Quality Management System (QMS) Installation</li> </ul>	
--	--

Note:

#### 4.7 Action Plan on DPR:

Sr No.	Action	Responsibility	Target date
1	To seek sanction from GOI	O/o DC(HC), New Delhi ?	?
2	To obtain sanction from GOI	O/o DC(HC), New Delhi ?	?
3	Execution of the project w.e.f 2016-17 Session	Chief Executive Designate ISTU	?

Note: ? to be fixed appropriately by the engaged consultant as per guide line of DC(HC).

## 7.4 EC Minute dated 19-05-2015 discussing the issues.

### 3.1 Futuristic Plan (SFC/EFC):

Action over DPR to be taken by IICT cell O/o DC(HC). For Non Plan, O/o DC(HC) will ensure clearance of pay & allowance allocation through non plan budgetary provision for the year 2015-16 at the earliest. In the DPR/SFC proposal in hand, management courses covering Finance/Marketing/International Business may be planned where focus on Carpet & Textiles industry may be ensured.

The VIP reference for upgrading IICT to a Textile University was discussed in detail. The committee members expressed concern about its viability. Hence advised IICT to submit a proposal to survey the feasibility under R&D scheme of DC(HC) to be carried out involving expert preferably from Department of Management studies, IIT, Delhi and Textile Technology Department, IIT, Delhi with due approval of Development Commissioner (Handicrafts) to conduct a survey and study the feasibility of such up gradation.

### 3.2 Conduction of Training under various projects/schemes including CHCDS/ ISDS:

The committee noted the status and proposal for continued participation in ISDS. As regards continuation of CHCDS to complete the pending training to 3000 persons the committee is of the opinion that this part if implemented invariably has to be in the similar line to that of CEPC.

### 3.3 Inverter Procurement and distribution:

**Inverter Procurement:** The committee was apprised about the decision on the BID and discussed in detail in this regard. A committee comprising CEPC, IICT and representative of O/o DC(HC) under the chairmanship of Director (HC) to finalize the tender document including specification and technical evaluation criteria afresh to avoid any ambiguity and submit for approval of DC(HC) before issuing notice inviting tender from the publicity section of O/o DC(HC).

**Inverter distribution:** The committee was apprised about status of application received mentioning the fact that non of the application fulfills the verification norms as per notification. Hence it was advised that IICT to send the details to respective District Magistrate for organizing verification to facilitate identification of beneficiary meeting notified norms

### 3.4 Extension for Phase-II EFC:

The approval for extension till 2015-16 and remaining fund to be provided by O/o DC(HC) at the earliest.

**3.5 Recruitment for filling up of posts of IICT:** Committee was apprised about the requirement and file submission to O/o DC(HC) for taking the recruitment process ahead. It was further decided that for additional requirement as already approved in SFC Phase-II, IICT to take up with O/o DC(HC) for subsequent approval from Ministry of Finance.

**3.6 Service Rule:** The committee was apprised about the inputs given for upgrading the service rule which is long due in view of statutory compliance including meeting requirements of 6<sup>th</sup> CPC. Director (HC) shall take up involving IICT staff and finalize the issue.

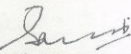
  
(Samir Kumar Biswas)  
Chairman

  
(P.K. Thakur)  
Vice-Chairman

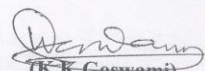
  
(K.K. Goswami)  
Member Secretary

7.5 Copy of proposal submitted by IICT dated 16-6-2015

No.21/PD/1/IICT/14/100

Date: 10.06.2015

To,

**Development Commissioner (HC), Chairman, IICT**

**O/o DC(HC),**

**West Block No. VII, R.K.Puram**

**New Delhi-110 066**

**Sub: Project Proposal on Upgradation of IICT to a Textile University-reg.**

Sir,

This is in reference to above mentioned subject. It is pertinent to mention that during 50<sup>th</sup> SGM on 19.05.2015 the above was discussed and resolution taken was as under.

“3.1 **Futuristic Plan (SFC/EFC)**: The VIP reference for upgrading IICT to a Textile University was discussed in detail. The committee members expressed concern about its viability. Hence advised IICT to submit a proposal to survey the feasibility under R&D scheme of DC(HC) to be carried out involving expert preferably from Department of Management studies, IIT, Delhi and Textile Technology Department, IIT, Delhi with due approval of Development Commissioner (Handicrafts) to conduct a survey and study the feasibility of such up gradation”

In accordance, we are submitting the proposal under R&D Scheme of O/o DC(HC).

**Yours faithfully,**

**Prof.(Dr.) K K Goswami**

**Director, IICT**

Encl: as above

## PROPOSAL on “Feasibility study for up-gradation of IICT, Bhadohi to Textile University”

### Organization Profile:

1.	Name of the organization, complete postal address with PIN, Mobile /telephone no., e-mail.  <i>Indian Institute of Carpet Technology, Chauri Road, Bhadohi ( Sant Ravidas Nagar)-221401</i>
2.	Registration number, date of registration, validity of registration. ,Act under which registered  <i>130/2014-15/V-21211/YRS</i>
3	Name & designation of Chief functionary with Tel No. /Mobile No  <i>Prof. Dr. K. K. Goswami, Director Phone No. 05414-228404, 9839834157</i>
4	Whether the organization is engaged in the development, promotion & marketing of handicrafts:  <i>YES</i>
5	If yes, whether it is incorporated as one of the objectives in the Memorandum and Article of Association of the Organization  <i>YES</i>
6	Has the agency under taken any study related to Handicraft, if yes, details thereon  <i>IICT, Bhadohi works in its four well defined portfolios viz. HRD, Design &amp; Development, Research &amp; Development and Technical services to the carpet sector. It is working for carpet based handicrafts for training of artisans, developments of newtools and techniques, design developments, new product development etc.</i>
7.	Other studies pertaining to informal sector undertaken by the agency  <i>Nil.</i>
8	Brief note on the activity undertaken  <i>Nil</i>

9.	Experience in organizing such activities Nil
<b>Project/Scheme profile:</b>	
10	<b><i>Name of the project</i></b>  "Feasibility study on up-gradation of IICT, Bhadohi to Textile University"
11	<b><i>Craft to be covered</i></b>  <i>Textile and allied courses</i>
12	<b>Area to be covered</b>  National and international students
13.	<b>Duration of the project along with break-up of all activities to be taken</b>  6 months duration involving survey through opinion of experts and also professional bodies for approval and affiliation of course. Future consent of external affair ministry and HRD Ministry would be required. For financial support MOT through DC(HC) and also HRD ministry would be required. IICT being primarily expertise in carpet craft , for other core textile courses and allied courses in management related to textile sector, GMT etc professional in the core subjects may required to be employed/deputed. For all these are activities a financial proposal under item 20 is sought.
14.	<b>Scope of the study</b>  The projects aims to depute consultant/ expert for the various activities and formalities. A report on the feasibility of the project would be submitted to the authority for approval of sanction with financial assistance.
15.	a. <b>Need/justification for taking up this project</b> In SGM of the institute the topic is discussed and is desired by the MP, Bhadohi Sh. Virendra Singh. It ahs been resolved Hence IICT , Bhadohi desires to work out the proposal in association with professional consultant and experts for the feasibility of the project physically and also finically.  b. <b>Methodology</b> 1. depute consults/expert . 2. feedback from others in the fields like industrialist/ academicians 3. submit the proposal to MoT through DC(HC)
16.	<b>How it will benefit to sector</b>  To be compiled through the expert opinion.

17.	Whether the study/survey on this subject has been conducted earlier by any agency , if yes, details thereon.			
	No			
18.	Curriculum, vitae, resume of the team involved in conducting the study.			
	Staff of IICT, Bhadohi in association of experts/ consultants .			
19.	Implementation module			
Financial Implication				
20.	Total financial implication along with head wise breakup			
	Sr no	Head	number	Amount in Rs. Per month
	1.	Project leader @ Rs.40,000 /- p.m.	01	40,000 /-
	2.	Senior research expert @ Rs. 25,000/- p.m.	02	50,000 /-
	3.	Junior research fellow @ Rs. 15,000/- p.m.	02	30,000 /-
	4.	Investigator @ Rs. 12,000/- p.m.	02	24,000 /-
	5.	Computer operator @ Rs. 10,000/- p.m	01	10,000 /-
	6.	TA/DA @ 18000 pm	-	18,000 /-
	7.	Documentation and ideography	-	. 1,00,000 /-
	8.	Miscellaneous @ 10 Of project cost	-	17200/-
	<b>9.</b>	<b>Total</b>		<b>189200/-</b>
				1135200/-
Documents to be attached				
21.	Copy of valid registration certificate under proper stature. (self attested)			
	Annexure II			
22.	Copy of memorandum of association			
	N A			
23.	Copy of audited balance sheet			
	N A			
24.	Copy of last three year annual reports			
	N A			



25.	copy of minutes of last SGM Annexure II
26.	List of current office bearers N A
27.	Copy of resolution for seeking financial assistance from office of DC(HC) N A
28.	Name and address of Bank N A
29.	Details of grant received from the office of DC(HC) during last 3 years and its status of Utilisation. N A
30.	Details of grant received from other central/ state govt deptt. Or agencies during last 3 years. Nil
31.	Name of Nodal officer / project head with complete address Dr. K K Goswami Director.
32.	Affidavit that the organization is not involved in corrupt practice / non profit making N A

### **Certificate**

1. Certificate that no financial assistance has been received from any other source for the same purpose.
2. Certified that the provision of the scheme has been fully understood and we take the responsibility for successful completion of the project within the same financial year.
3. Certified that all infrastructures are available with the organization to conduct the programme as per scheme.
4. Certified that there is no duplication of efforts takes place with existing schemes of the Ministries.

Signature of the authorized Person  
with Rubber Seal  
Name : Dr. K K Goswami.

Date:

Designation : Director.

## 7.6 Grant from Office of DC (HC) dated 04-09-2015

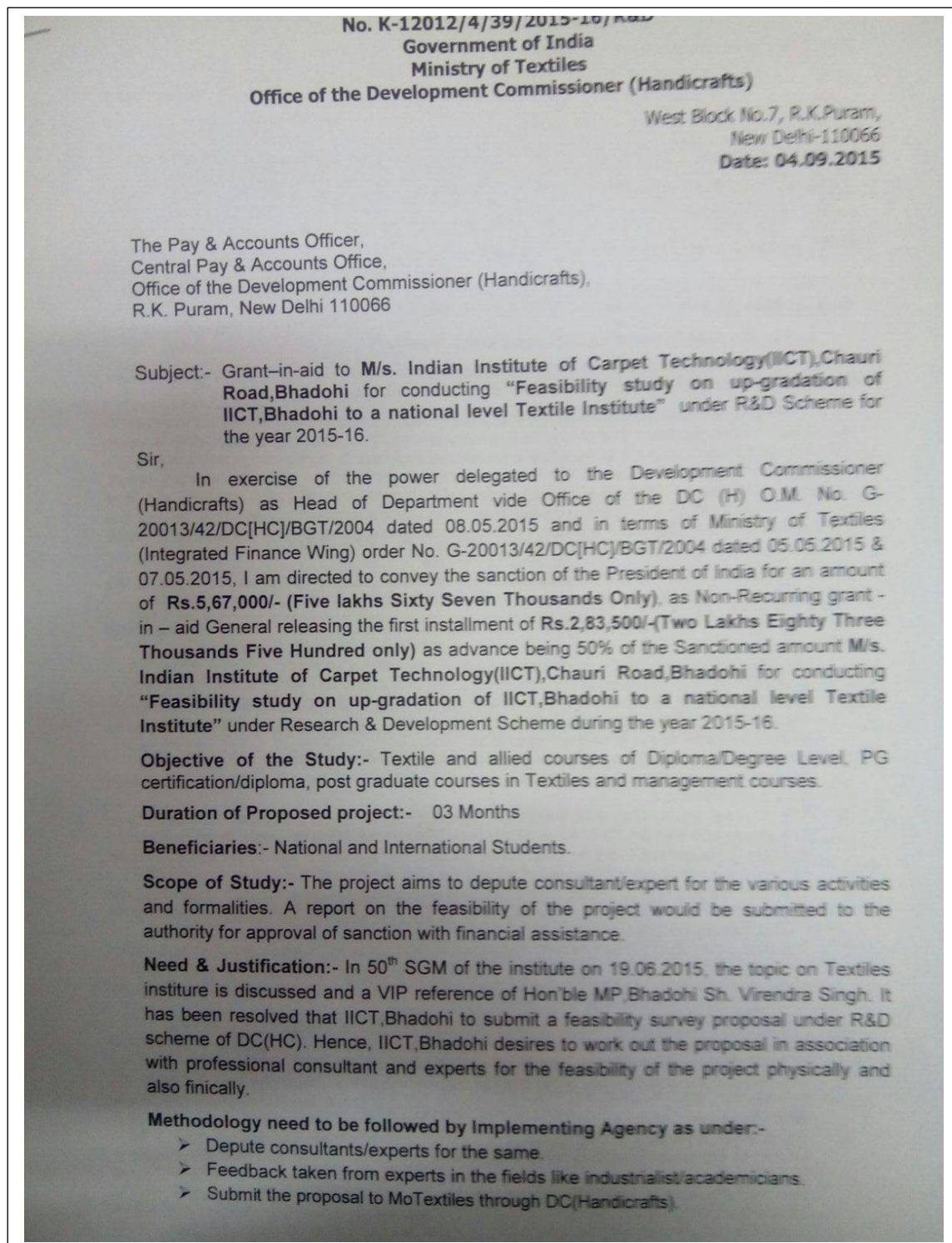

The Financial Implications are as under:-

Sl. No.	Head	Amount Sanction [Rs.]
		1,20,000/-
1.	01 Project leader @ Rs. 40,000/- p.m.	1,50,000/-
2.	02 Senior Research Expert @ Rs. 25,000/- p.m.	90,000/-
3.	02 Junior Research Fellow @ Rs. 15,000/- p.m.	72,000/-
4.	02 Investigator (Graduate) @ Rs. 12,000/- p.m.	30,000/-
5.	01 Computer Operator @ Rs. 10,000/- p.m.	54,000/-
6.	TA & DA	51,000/-
7.	Miscellaneous Expenses including Documentation	
	<b>Total</b>	<b>5,67,000/-</b>

**Mode of Payment:**

The sanctioned amount will be released in two installments.

The first installment amounting to Rs.2,83,500/- (Two Lakhs Eighty Three Thousands Five Hundred only) will be released on submission of the pre-receipted bill & acceptance of terms.

Second and final installment in the shape of reimbursement after completion of the project & submission within stipulated time of sanctioning of the project & thereafter submission of final report indicating performance and follow up action to be taken duly agreed to, by the competent authority (six hard copies and two soft copies in CD Room and audited statement of accounts, auditor's report, utilization certificate in GFR 19-A in respect of the 1st installment of grant released and total expenditure incurred on the project on the letter head of Chartered Accountant duly verified and countersigned by the authorized signatory of the organization and acceptance of the reports, standard formulation regarding qualitative and quantitative targets.

Deduction of tax at source under Income Tax Rules (Section 194 J) will be made at the applicable rates for the assessment year.

Certified that no Utilization Certificate is pending against the organization in R&D scheme of this office.

**Terms and Conditions:-**

- The organization shall interact periodically with Office of the Development Commissioner (handicrafts) or their representative/experts for understanding the problems being addressed through this project and firming up the outputs.
- Grant-in-aid/funds shall be utilized for the aforesaid study.
- The grantee/ organization shall maintain subsidiary accounts of the grants/ payments received from the Government.
- The grantee/ organization shall maintain a register of assets in the prescribed form GFR-19-A. The assets acquired wholly or substantially out of Government Grants except those declared as absolute and unserviceable or condemned as per the procedure laid down in the General Financial rules shall not be disposed of without the prior approval of this office.
- The grantee/organization shall submit performance-cum-achievement report physically and financially on or before 10th of every month to DC (Handicrafts) Office, New Delhi and its Regional Office (NR), New Delhi.
- The amount so paid to the grantee/ organization shall be open to inspection by the Sanction Authority i.e. O/o DC(Handicrafts)/Internal Audit Party of the Chief Controller of Accounts, Ministry of Commerce and Textiles, New Delhi whenever the grantee/ organization is called upon to do so.
- The grantee/ organization shall get its accounts audited from the Chartered Accountants.
- The grantee /organization shall not divert the grants/funds and entrust execution of the scheme or work concerned to another Institutions or Organizations and shall abide by the terms and conditions of the grant/funds. If the grantee /organization fail to utilize the grant/funds for the purpose for which the same has been sanctioned, the grantee /organization will be required to refund the amount of the grants/funds with interest thereon @ 10% per annum.
- The grantee/ organization shall submit the utilization certificate in the form GFR-19A and a list in respect of assets being created out of Government grant/funds, if any, duly signed by the Head of the Grantee/ organization Institution and audited by the Chartered Accountant within stipulated time from the date of completion of the project. The Utilization Certificate would indicate the achievements against the specified quantitative targets and also disclose whether the specified qualitative targets that should have been reached against the amount utilized were in fact reached and if not, the reasons therefore.



- j) The grantee /organization agree to make reservations for scheduled castes and scheduled tribes in posts/services under its control on the lines indicated by the Government of India.
- ki) There is no reason to believe that the grantee/ organization are involved in corrupt practices.
- l) The expenditure shall be incurred as per GFR provision and department of the expenditure guidelines.
- m) The component-wise breakup of the sanctioned amount represents the permissible upper limit of expenditure and the admittance thereof shall be subject to actual.
- n) All the Payments above Rs. 5000/- may be made by Account payee cheque/Demand Draft/ECS/RTGS.
- o) The payments made by cash should not exceed 10% of the grant sanctioned.
- p) Payment to Trainees/Designers/Master Crafts Persons/Experts, etc. invariably be made through A/C payee Cheque/Demand Draft even if the claim is less than Rs. 5000/-.
- q) The implementing agency shall intimate the M&SEC as well as RDs concerned minimum 30 days in advance about the scheduled event and Hqrs. shall be informed at least 20 days in advance.
- r) All the participants should have artisans id card/Aadhar no./PMJD account number.
- s) The proposal may be invited from reputed agency through open advertisement and selection may be made be transparent manner following scheme guidelines/relevant rules/GFR etc.
- t) In case of studies, literature survey of earlier studies must be done and ensured that the same study has not been done in the past.
- u) The existing exporters must be consulted and the names of those exporters must be reported with performance report.
- v) It may be noted that the final report submitted by the organization should clearly mention the name of the sponsor on the cover page as reproduced below:

Sponsored by Development Commissioner (Handicrafts),  
Ministry of Textiles,  
Government of India

The Accounts Officer (Hqrs.) Office of the Development Commissioner (Handicrafts), New Delhi is authorized to draw and disburse the amount in question.

The expenditure involved is debit to the Major Head of account 2851-Village & Small Industries, 00104 - Handicrafts Industries - 38.05 Research and Development Scheme (Plan) under sub head - 380531 - GIA - General and will be met within the sanctioned Budget for the financial year 2015-16 where sufficient funds are available.

This issues with the approval of DC (Handicrafts) vide Dy. No. 2925 Dated 04.09.2015

Entry has been made in the Grant-in-Aid register at Page No. 05 at Sl. No. 45.

*Hanuman Meena*  
(Hanuman Meena) 04/09/2015  
Assistant Director (R&D)

Copy to:-

- 1) M/s. Indian Institute of Carpet Technology(IICT),Chauri Road,Bhadohi for conducting "Feasibility study on up-gradation of IICT,Bhadohi to a national level Textile Institute" with the request to submit the following documents immediately:
  - a. Stamped pre-receipt in triplicate on the letter head of the organization for an amount of Rs.2,83,500/- (Two Lakhs Eighty Three Thousands Five Hundred only) being the 1st installment, mentioning the sanction number, with date, purpose, bank account number, name of the bank and branch.
  - b. Acceptance of the enclosed terms and conditions of the project in triplicate on letter head of organization.
  - c. Enclosed from dully filed for ECS payment.
  - d. Prescribed Bond & Certificate on affidavit that no fund has been received from any Office/Department for the above Seminar/Workshop.
- 2) Deputy Secretary, IFW, M/o Textiles, Udyog Bhawan, New Delhi
- 3) Principal Accounts Officer, M/o Textiles, Udyog Bhawan, New Delhi.
- 4) Principal Director of Audit Economic and Services Ministries, I.P.Estate, AGCR Building New Delhi.
- 5) Regional Director (CR), O/o (Handicrafts), Lucknow.
- 6) Assistant Director, Marketing Centre, O/o (Handicrafts), Varanasi,U.P.
- 7) Accounts Officer, (HQ) O/o (Handicrafts) New Delhi,
- 8) Accounts Officer, (B&A), O/o (Handicrafts) New Delhi.
- 9) Guard file/Computer cell/Hindi Section for Hindi version.

*Hanuman Meena*  
Assistant Director (R&D) 04/09/2015

7.7 Roadmap for execution of the project dated 14-09-2015 and discussion on 15-09-2015

**Road Map**

**Name of the project** : Feasibility study on up-gradation of IICT, Bhadohi to a national level Textile Institute under R & D Scheme.

**Sanction order No.** : K-12012/4/39/2015-16/R&D

**Date of Sanction** : 04-09-2015

**Sponsored by** : Office of the Development Commissioner (Handicrafts)

**Duration of proposed project** : 03 months.

**Objective of the study** : Textile and allied courses of Diploma/Degree level PG certification /diploma, post graduate course in Textile & Management courses.

JAK No. 2224  
DATE 18/9/15  
DMC, IICT BHADOLI

Methodology	Action to be taken	Time Schedule
1. Depute Consultants / experts	1. The project to be led by Director, IICT himself. Other identified consultants/experts are Professor R.Chattopadhy, Ex HOD Textile Technology Division and Professor D.K.Banwet, emeritus Professor Department of Management Studies both from IIT New Delhi and Asso. Professor K.K.Bajpai from School of Management Science, Varanasi or as Directed by O/o DC(HC) while discussing during the period 14 to 16 Sept 2015. Supporting resources as per the sanctioned head shall be outsourced. They will be paid within the Financial Sanction and as per agreed TOR to be in place.	Consent from all the three experts obtained. Concept note sent for their study. TOR is being discussed in the second week of September-2016 with the experts as proposed.
2. Feedback taken from experts in the field like Industrialist / academicians	2. Feedback shall be obtained from the experts in the field including Industrialist / academicians as well selected social / political / administrative / media persons of this area and outside this area. The format to be developed by the deputed consultants jointly. The aim of the feedback shall be such by which it should be possible to adjudge the need and justification based on estimated physical & financial investment.	Feedback collection to be completed by December-2015. Analysis of feedback by January-2016. Submission of Report by February-2016.
3. Submit the proposal to MOT through (DC) Handicrafts	The analysis of the feedback shall be done by the same team. The responsibility for the whole exercise shall be designed appropriately and reviewed by the project leader. In this regard the concept note submitted earlier by Director, IICT to DC(HC) through Director (HC) shall be shared.  3. The report "Feasibility Study on up-gradation of IICT, Bhadohi to a National level Textile Institute" of the university level shall be submitted latest by February-2016 to the authority for approval of sanction with financial assistance, so that DPR can be prepared in accordance.	

*DMC / dpc* *Amresh* *14/9/15*

*Submitted for kind perusal / monitoring and advise if any (This Report 3)*

*DIR (HC), Vice chairman IICT* *14/9* *14/9/15* *Camp H&M*



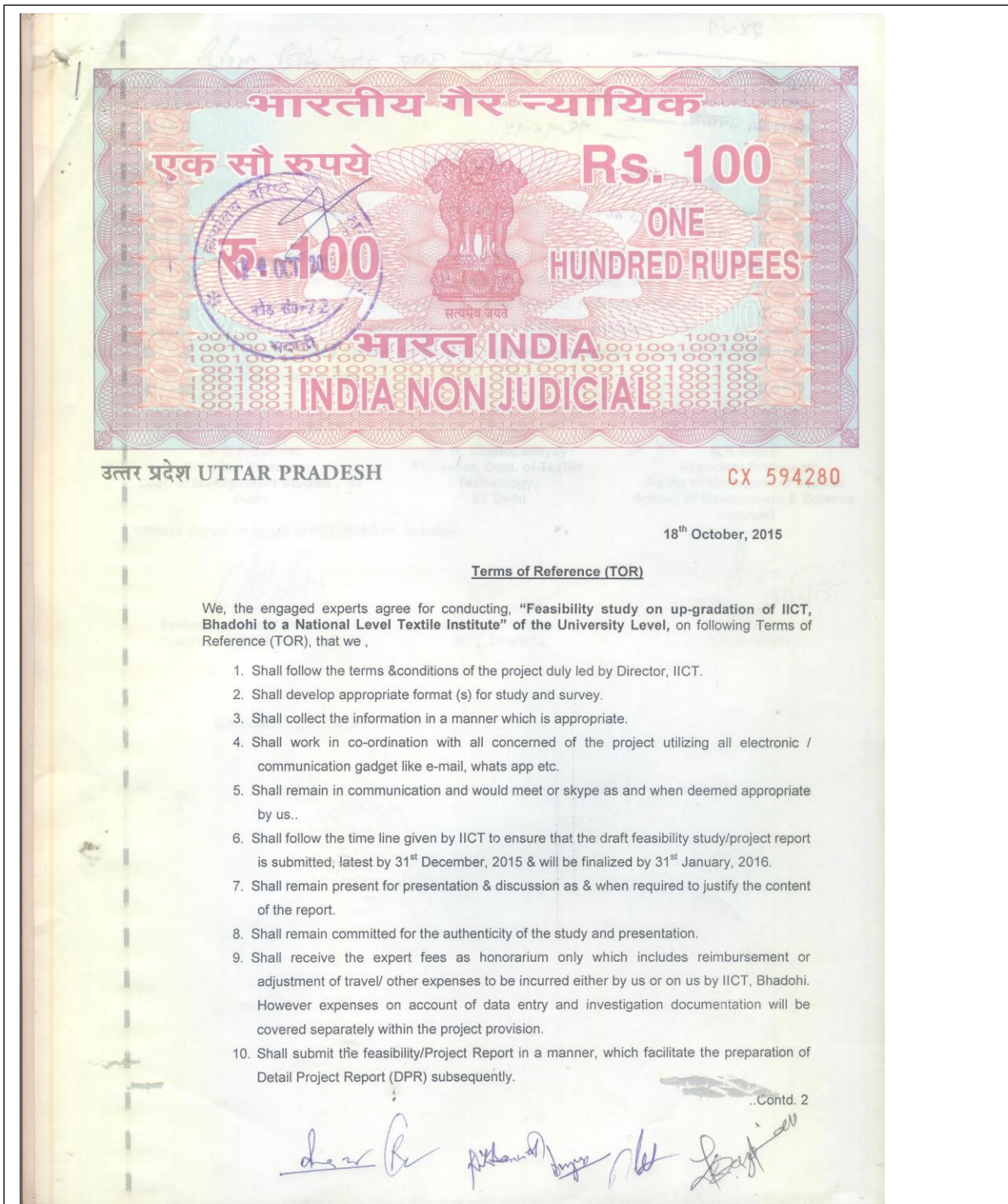

## 7.8 TOR signed by consultants dated 18-10-2015

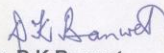

11. Shall provide the record of data of study/survey in hard and /or soft form (as available or generated).
12. Shall take the reference of Background Note:1/10/DMC/DIR/Gen/2015, dated 01.10.2015 , Road Map dated 14.09.2015, Minutes of first Meeting, dated 15.09.2015 ( copy enclosed, 3 pages) for the related purpose/ Terms of Reference (TOR) etc.
13. Shall ensure, in coordination with Mr. K.K.Bajpai, Associate Professor, School of Management & Science, Varanasi, local expert, the persuasion of activities to execute the assignment in time.

  
Dr. D.K. Banwet  
Emeritus Professor,  
Dept. of Management Studies , IIT  
Delhi

  
Dr. R. Chattopadhyay  
Professor, Dept. of Textile  
Technology,  
IIT Delhi

  
K.K. Bajpai  
Associate Professor  
Faculty of Management Studies  
School of Management & Science,  
Varanasi

Witness thereof on behalf of IICT, Bhadohi, as below :

  
Dr. S.K. Pal  
Professor & Chief Project  
Coordinator, IICT, Bhadohi

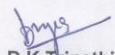
  
D.K. Tripathi  
Accounts Officer  
IICT, Bhadohi

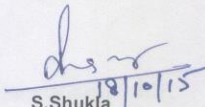
  
S. Shukla  
ASO,  
IICT, Bhadohi

Submitted to Director IICT

CPC

  
18/10/15



7.9 Copy of covering letter related to presentation of preliminary DPR dated 23-11-2015 and minutes of meeting with direction.

 **भारतीय कालीन प्रौद्योगिकी संस्थान**  
(आई एस ओ 9001 : 2008 प्रमाणित)  
विकास आयुक्त (हस्तशिल्प), वस्त्र मंत्रालय, भारत सरकार, के अधीन  
उ० प्र० प्राविधिक विश्वविद्यालय द्वारा सम्बद्ध एवं अमाताशिप, भारत सरकार द्वारा अनुमोदित  
**INDIAN INSTITUTE OF CARPET TECHNOLOGY**  
(ISO 9001 : 2008 Certified)  
Under the aegis of the Development Commissioner (Handicrafts), Ministry of Textiles, Govt. of India  
Affiliated with U.P. Technical University & Approved by AICTE, Govt. of India



पत्रांक / Ref : 3/5/IICT/SFC/EFC/2015-16/ दिनांक /Date 23-11-2015

To,  
Development Commissioner (Handicrafts)  
O/o DC (HC), West Block No.-VII  
R.K.Puram,  
New Delhi-110 066

निदेशक / Director  
कार्य सं./Op. No. 593  
2/11/15

through Director (HC), Vice-Chairman IICT

**Subject: Modified DPR for EFC/SFC for continuation of existing activities of IICT, Bhadohi-reg.**

Sir,  
This refers to above mentioned subject, in this regard, EC of IICT resolved vide meeting dated as under-

**Meeting dated 13-06-2014:**  
"In view of consideration of coverage of Pay & Allowances under Non Plan for IICT by the Ministry of Textiles, DC (HC) desired IICT to assist IICT Cell of O/o DC(HC) in formulation of the modified EFC document excluding the Pay & Allowances, for subsequent action at the earliest." (copy of minute enclosed)

**Meeting dated 08-09-2015:**  
"The committee advised IICT Cell of O/o DC(HC) to return the DPR to Director, IICT with the advised to submit revised DPR incorporating additional emerging inputs. Further Chairman, IICT advised to complete "Feasibility study of Up-gradation of IICT to national level Textile Institute" of University level at earliest following a roadmap engaging relevant experts with due intimation to Vice-Chairman, IICT." (copy of minute enclosed)

Further to above O/o Development Commissioner (HC) vide letter No.1-11020/14/2015-16/IICT/444 dated 09-11-2015, directed by the Development Commissioner (HC) to make lucid presentation on 23-11-2015 at 3 PM.

In compliance to above, enclosed please find the fresh DPR (duly filled in EFC/SFC format/memorandum). However, PPT presentation is proposed to be made on 23-11-2015 in the O/o Development Commissioner (HC)

Submitted for taking necessary action for proposed expansion programme including continuation of existing activities in respect of Indian Institute of Carpet Technology, Bhadohi.

Yours faithfully  
Prof. (Dr) K.K.Goswami  
Director, IICT

encd=9/a  
Pl. Resp.  
Proposer has been done before DC(HC) - Modification has been accepted. Authority Director will modify

पता- चौरी रोड, संत रविदास नगर भदोही - 221401 ; फोन / Phone: +91 5414 228404, 228409, 225504. फ़ैक्स / Fax: 05414 225509  
Address: Chauari Road.S.R.N Bhadohi - 221401 ; ई-मेल/ Email: iict@iict.ac.in, वेबसाइट / Website: http://iict.ac.in



7.10 ASFA's view /advice for incorporation in expansion plan.

**INDIAN INSTITUTE OF CARPET TECHNOLOGY**  
**CHAURI ROAD, BHADOHI-221 401**

28.10.2015

**Note**

This refers Tour Note of Shri J.K.Daño, IAS AS &FA, DoC/MoT ON HIS VISIT TO VARANASI ON 10-11 OCTOBER, 2015 forwarded to this office by Director (HC), O/o DC(HC) for compliance. Based on comments of AS&FA in visitor book of IICT, compliance note had already been submitted dated 12.10.2015 to Director (HC) through email which is as under. The status and proposed action plan on the issues raised by AS&FA is as under

Sr No.	Issue raised by AS&FA	Present status	Remarks/action plan
1	Upgradation- facilities in classrooms, testing labs, Library, Design Deptt. teaching infrastructure.	Upgradation in improving seating arrangement, procurement of lab equipments, Procurement of Library and teaching infrastructure including improved service rule already under consideration at IICT level and at the level of O/o DC(HC)	To be taken care of by means of upgradation plan in hand through SFC-III and feasibility study on converting IICT to a institute of national importance of University level
2	Swachch Bharat	IICT has already involved all students and faculty though Mentor Circle System. Whitewashing etc are in process.	Much more widespread publicized activity will be taken up through campaigning awareness and infrastructural improvement etc.
3.	Greening & more fruit tree & flowering, plants	IICT is continuously and actively involved in this activity in the last 15 years.	Biodiversity approach in planting various trees including fruits will be taken up.
4.	rain water harvesting	It is in pipeline as already identified.	The action will be expedited.
5.	solar energy generation/ compost pits	Already conceptualized and solar heating water in boys hostel already implemented.	Total captive generation and consumption is being planed and budget estimate will be prepared and submitted as appropriate.
6.	Mass customization of R& D Projects	All attempt has been made to customize in form of communication to users. Many projects have been converted to intellectual property followed by licensee and commercialization.	More efforts for mass customization will be taken up to create more impact.
7	Fuller 6 months Training programe for self help	Existing programs is of 3 months under CHCDS and continuing	Only after changed sanction order and

DAK-No. 4356

	groups	according to the course curriculum, duration etc as per MES acceptable to all concerned agencies.	allocated funds it can be done.
8	Maintenance of alumni record	Record exists. First time alumni meet has already been scheduled in the month of December, 2015	To upgrade the record for improved communication and interaction. A fund allocation and utilisation plan shall be made after finalizing the source of availability forming alumni secretariat etc.
9.	To become institute of national importance	It has already been conceived by DC(HC) vide previous SGMs. In accordance IICT has been assigned for conducting a feasibility study on upgradation of IICT, Bhadohi to a national level textile institute. Dr. D.K.Banwet, Emeritus Professor, DMS, IIT, Delhi and Dr. R.Chattopadhyay, Professor & Ex. HOD, DoTT, IIT, Delhi, Shri K K Bajpai, Asso Professor, School of Management Science, Varanasi have been assigned as experts to conduct the study and submit the report under the leadership of Director, IICT.	2 <sup>nd</sup> Meeting is scheduled on 17-18 Oct, 2015 at IICT, Bhadohi wherein TOR will be finalized based on the roadmap already in hand. O/o DC(HC) may provide necessary inputs in this regard so that document can be prepared by the experts in a manner as desired by the Ministry and Govt.

Submitted for advise.

Prof. K K Goswami, Director, IICT

Director (HC), Vice-Chairman, IICT

Development Commissioner (HC), Chairman, IICT



**INDIAN INSTITUTE OF CARPET TECHNOLOGY**  
**CHAURI ROAD, BHADOHI-221 401**

NOTE

Below please find the comments of **Shri J.K.Dadoo, IAS Additional Secretary and Financial Advisor, Ministry of Commerce & Textile, GOI** during his visit to IICT dated 10.10.2015. In this context, all the concerned of IICT are requested to kindly do the needful wherever and whenever you get the opportunity of upgradation/improvement in the interest of institute to become an institute of national importance.

12.10.2015  
**Prof. K. K Goswami, Director, IICT**

- To,**
- (i) All IICT employees (ii) Dean, IICT (iii) Registrar, IICT (iv) HOO, IICT (v) ASO, IICT (vi) AO, IICT (vii) Librarian (viii) Notice Board
- Copy to**
- (i) Director(HC), Vice-Chairman, IICT O/o DC(HC), New Delhi for kind information.
  - (ii) Development Commissioner (HC), Chairman, IICT O/o DC(HC), New Delhi for kind information.

Date	Name & Address	Comments
10/10/15	<p>J.K Dadoo IAS                      Addy Secy of Financial Advisor                      Min of Commerce &amp; Textile</p>	<p>A pioneering institute in Carpet technology. Now needs upgradation. Facilities in classrooms, labelling, etc. Teachers infrastructure should should be a priority. Give up ram workshop. solve every generation, import pits must be there. have foot Meer, flowers, plants etc. etc. More exhibition of hand made, full time growth and maintenance of groups, record is important. institute not give excellent to become an institute of national importance. My best wishes to you.</p> <p style="text-align: right;">10/10/15</p>

**Prof. K. K Goswami, Director, IICT**



**Indian Institute of Carpet Technology**

Bhadohi, Uttar Pradesh, India